

This work is licensed under a Creative Commons Attribution-NonCommercial-NoDerivs 3.0 Licence.

To view a copy of the licence please see:
<http://creativecommons.org/licenses/by-nc-nd/3.0/>

A MANAGEMENT SYSTEMS APPROACH
TO RURAL DEVELOPMENT

BY

Deryke Belshaw and Robert Chambers*

DISCUSSION PAPER NO.161

INSTITUTE FOR DEVELOPMENT STUDIES
UNIVERSITY OF NAIROBI

JANUARY 1973

* Deryke Belshaw is a Senior Lecturer with the School of Development Studies, University of East Anglia and carried out the research on which this paper is based when a Research Associate of the Institute for Development Studies, University of Nairobi. Robert Chambers is a Fellow of the Institute of Development Studies, University of Sussex and began the research on which this paper is based when a Senior Research Fellow of the Institute for Development Studies, University of Nairobi.

Any views expressed in this paper are those of the authors. They should not be interpreted as reflecting the views of the Institute for Development Studies or of the University of Nairobi.

I.D.S. Discussion
Paper No. 161

A MANAGEMENT SYSTEMS APPROACH
TO RURAL DEVELOPMENT

By

Deryke Belshaw and Robert Chambers

Abstract

Past failures to plan rural planning, planners' relative neglect of recurrent resource management, and the underutilised capacity of government field staff all support the case for increased attention to be given to management procedures in rural development. A simple systems presentation is used to set out a rural plan management system with six component systems:

Programming and Implementation Management
Field Staff Management
Local Participation Procedures
Evaluation Review Sequence
Rural Research and Development
Plan Formulation Procedures

Management procedures for these six systems either have been or are being developed and tested in the Kenya Government's Special Rural Development Programme. They are described in turn. Choices and principles in system design and in replication both within Kenya and in other countries are discussed. The most important single conclusion is that public sector performance in rural development is most likely to be improved initially through attention to programming, implementation and monitoring, with later gradual extension through evaluation to plan formulation.

CONTENTS

	<u>Page</u>
Abstract	
Acknowledgements	
Abbreviations	
1. The Need for a Management Emphasis	1
2. The Utility of a Systems Approach	5
3. The Programming and Implementation Management System (PIMS)	7
(i) The Annual Programming Exercise	9
(ii) The Monthly Management Meeting	10
(iii) The Monthly Management Report	10
4. Field Staff Management Systems (FSM)	11
5. Local Participation Procedures (LPP)	14
(i) Taking account of local wishes	15
(ii) Making use of local knowledge	16
(iii) Securing local contributions	16
6. The Evaluation Review Sequence (ERS)	17
(i) The Annual Implementation Review	18
(ii) The Plan Evaluation Review	19
(iii) The Interim Implementation Review	20
7. Rural Research and Development (RRD)	20
8. Plan Formulation Procedures (PFP)	22
9. Replication and Choices	25
References	
Figure 1: The Rural Plan Management System	
Figure 2: Management Loops and Periodicities in the Rural Plan Management System	
Figure 3: A Sequence for Progressive Replanning with the Rural Plan Management System	

ACKNOWLEDGEMENTS

We wish to acknowledge the assistance we have received from many officers of the Kenya Government and others in the identification, development and testing of the six systems described in this paper. We hope to be able to acknowledge their individual contributions in subsequent papers describing each system. In the meantime, we would like to express our special gratitude to J.W. Leach, Special Rural Development Programme, Ministry of Finance and Economic Planning, and W.P.M. Saisi, J.K. Okidi, J.A. Omungo, and D.G.K. Wanjala, the Area Coordinators of Mbere, Napenguria, Vihiga and Migori Divisions, without whose support, contributions and willing cooperation the development, implementation and testing of the rural plan management system could not have been achieved. Further thanks for cooperation are due to J.I. Mwaniki, formerly of the Ministry of Finance and Planning; J.J. Gichuki, formerly District Agricultural Officer, Embu; J. Magajo, Assistant Agricultural Officer i/c Mbere Division and the entire field staff of the Ministry of Agriculture in that Division. Helpful discussions have taken place with many people, including T.W. Crawford, R. Nelson, H. Ogola and C. Trapman of the Ministry of Agriculture, Nairobi; H. Mule, D.O. Kungu, R.H. Clough, J. Tait Davis, J. Gerhart, and C.G. Widstrand of the Ministry of Finance and Economic Planning, Nairobi; with the Provincial Planning Officers of the Ministry of Finance and Economic Planning; and with T.J. Bjorlo, David Leonard, John Nellis, W.O. Oyugi, Niels Roling and M.M. Shah of the University of Nairobi.

ABBREVIATIONS IN THE TEXT

AAO	Assistant Agricultural Officer
AIR	Annual Implementation Review
APC	Annual Programming Chart
APE	Annual Programming Exercise
APT	Annual Phasing Form
ERS	Evaluation Review Sequence
FSM	Field Staff Management
FY	Financial Year
IIR	Interim Implementation Review
JAA	Junior Agricultural Assistant
LAA	Location Agricultural Assistant
LPP	Local Participation Procedures
MM	Monthly Management Meeting
MMR	Monthly Management Report
PER	Plan Evaluation Review
PPP	Plan Formulation Procedures
PIM	Programming and Implementation Management
R and D	Research and Development
RRD	Rural Research and Development
SRDP	Special Rural Development Programme

In this paper we take as given the priority attached to rural development by many less developed countries, the commonly experienced gaps between public sector targets and achievements in the rural sector, and the generally low levels of performance attributed to Government staff in rural areas. Our purpose is to present in outline a management systems approach to rural development which is designed to improve public sector achievements in rural areas and to assist the performance of field staff. The management system described here and its six lower-order component systems have been identified and are being developed and tested within the framework of the Kenya Government's Special Rural Development Programme (SRDP).¹ The principles upon which their design is based may apply anywhere, however, and the detailed systems themselves should be replicable with only minor modifications wherever there are broadly similar levels of executive capacity, similar institutions of rural administration, and adequate political commitment to rural development.

1. THE NEED FOR A MANAGEMENT EMPHASIS:

The rationale for a management approach to rural development might quite simply be based upon the widespread dissatisfaction with the current levels of performance of rural development agencies in less developed countries. The most cogent supporting arguments for a new approach are, however, more specific than this. They can be clustered into three groups.

In the first place, an analysis of the experience with rural development planning identifies a common failure to plan planning itself. At the risk of oversimplification, the desired set of planning activities can be presented as:

- (i) Plan formulation
- (ii) Budgeting
- (iii) Programming
- (iv) Implementation (including coping adjustments)
- (v) Monitoring (operational control)
- (vi) Evaluation ex post
- (vii) Reformulation of the plan
(repeat sequence)

In practice, planners have concentrated on the first and second activities to the neglect of the others: on plan formulation perhaps because of its intellectual attraction, its susceptibility to mathematical treatment, its

1. For which see Heyer, Ireri and Morris, 1971 and Nellis 1972.

separateness from the detail of administration, and its position at the beginning of the sequence of activities; and on budgeting partly because of its undeniable priority and intractable deadlines. Associated with these biases has been a preoccupation in the literature with plan formulation, often presented as a set of elaborate procedures, with relatively little analytical attention paid to implementation which is typically portrayed as a set of awkward problems. Symptomatic of this tendency has been the use of the word 'planning' to refer only to plan formulation activities. While these observations apply especially at the level of national planning (see Waterston, 1968), the same situation has occurred with planning for particular rural areas. Resources and effort have been devoted to data-collection, plan formulation and plan writing, while procedures for plan appraisal, implementation and evaluation have been relatively ignored. The result has often been plan formulation without implementation (Chambers, 1972), a form of mismanagement which has tended to be protected by the prestige of "planning" from the criticism it deserves.

Second, planners have been preoccupied with capital and development expenditure, with capital projects and with the creation of special project organisations, to the relative neglect of recurrent expenditure and of programmes which are implemented through existing field organisations. This preoccupation may originate in part from the bias of aid agencies towards financial aid tied to capital inputs; in part from the relative ease with which an economist can carry out his professional activities with a capital project compared with the difficulties of handling poor or missing data for a recurrent resource project (or, more typically, a programme of rather small individual projects); in part from the policy of some donor agencies, most conspicuously the IBRD, of preferring to ensure effective operation in the recipient country by creating a semi-autonomous organisation rather than risking operation through existing field organisations; and in part from the attraction of the more visible single, large "project" compared with the less visible dispersed field "programme".

From a national point of view, however, very large recurrent resources in the form of trained staff and operating expenses are already committed in the field. In some countries the iceberg analogy may be apposite - the visible tip representing the development projects and commitments which attract attention and analysis, while much larger recurrent commitments remain hidden and largely unanalysed below. In

Kenya, because of the relatively large development budget, this analogy does not strictly hold, but even in Kenya in recent years some two-thirds of total estimates approved have been for recurrent expenditures. Even in those sectors where the weight of the development expenditures is deployed - in the creation of production infrastructure and in direct investment in major productive activities - recurrent expenditures still provide about 40 per cent of total expenditures. More strikingly, the recurrent share in the total budget for 1972/73 of the Ministry of Agriculture - the third largest Ministry in Kenya in terms of total spending - is slightly larger than the development estimates' share (Kenya Government, 1972). The pattern in other less developed countries which are generally unable to match Kenya's relative access to capital aid is likely to be more marked. With such heavy allocations of national resources, especially scarce local finance and high-level manpower, being made without systematic analysis of the relevant choices open to the planning system, it can be seen that the management of recurrent resources in the public sector warrants much greater attention than it has received in the past.

Third, field staff are an underutilised resource. What Moris (1972) calls the "centrist ideology" of planning and administration in East Africa - the system of beliefs and attitudes which holds that initiative and control do and must reside primarily in the capital city, and elsewhere higher rather than lower in the hierarchy - has as a corollary the belief that field staff are generally rather ignorant, incapable, and untrustworthy, and lazy unless they are forced to work. This widespread view of human nature, the implications of which have been analysed by McGregor (1960), is incompatible with the levels of discretion and responsibility required for isolated field staff if they are to perform their functions well. Without a management system which allows, encourages and rewards the exercise of initiative and the performance of good work, it is scarcely surprising that field staff have often appeared to those in the centre to justify adverse comment. The centrist ideology in fact sustains the conditions which justify it. Overcentralisation prevents the exercise of initiative at lower levels, good performance passes unnoticed, and field staff fatalistically accept as a fact of life the flow of instructions and plans from above in the formulation of which they have not played any part. This picture can, of course, be overdrawn. But on the basis both of our own experience and of that of other social science researchers who have worked

in rural areas, one may assert with some confidence that the majority of field staff have much greater capability for managing their work than is currently assumed by their superior officers. Reforms are required, therefore, which will permit or even require field staff to attain the higher performance potentials of which they are capable.

These three lines of argument converge on the conclusion that attention should be devoted to developing management (as distinct from administrative) systems for field staff. This should involve first, a shift of planning attention towards programming, implementing and monitoring; second, a shift of emphasis from capital projects and the creation of special project organisations towards recurrent resource management and improving the organisations which already exist; and third an attempt to release and harness more effectively the energies and abilities of the staff who are in the field. Under its policy of decentralisation to the regions, Tanzania is currently taking a bold series of steps to enhance the responsibility and discretion of field staff, though whether this national programme will lead through into improved staff effectiveness at the lower levels must remain to be seen. Through its policy of introducing district planning, the Kenya Government intends to provide an opportunity for field staff to play a larger part in formulating development programmes for the districts in which they work. But in Tanzania, Kenya, and other countries, the danger remains that attention will continue to concentrate on plan formulation and budgeting and on visible and dramatic capital projects, rather than on the less spectacular but, we would argue, higher priority question of improving the management of the recurrent resource programmes which are already in hand or which are proposed. To achieve such improvement, much more attention needs to be paid to the design of management systems including the detailed specification of procedures.¹ This paper reports on one attempt to move in that direction.

1. Some of the arguments for attributing some primacy to procedures in rural development management are presented in Chambers, 1972.

2. THE UTILITY OF A SYSTEMS APPROACH

At a simple level, systems analysis has provided us with some of the techniques for describing and analysing the rural planning process and then for developing modifications and improvements. While we have benefitted from other work in the same or similar fields, most notably that of Kulp (1970) and Chadwick (1971), we have not found in these or other works a systems analysis of the rural development process which provides an adequate basis for prescription at the level of detailed procedures. Kulp, an engineer by training, presents a series of three diagrams of a planning system (1970: 8, 10, 11) but these use categories derived from engineering systems and do not provide, and were not intended to provide, a direct basis for the design of procedures. Indeed, a more recent attempt to relate engineering modes of thought to the public sector rural development process (Belshaw, BJORLO and Shah, 1972) suggests that while it is possible to present a hierarchical systems formulation, as widely used by engineers in multi-level control systems, its practical value is mainly heuristic. Chadwick's analysis of the planning process (1971) is closer to operations and prescriptions but stops short of the combination of comprehensiveness and specificity necessary for coming to grips with the complex real world of a particular regional environment and administrative situation. Our own approach tries to achieve practical utility by combining some of the simpler techniques of conceptualisation and presentation of systems analysis with an empirical examination of public sector processes already occurring in rural development in one country.

It is, in fact, a systems way of thinking¹ and presentation, much more than any recondite language or technique, which has proved useful. In Kulp's characteristically blunt words:

"Systems analysis has grown up talking to computers and it carries with it the programming jargon. This can give a very false aura, a delusion of rigor, incisiveness and profundity - when one is actually saying no more than 'The knee bone's connected to the leg bone'." (1970: 11)

It has proved an excellent discipline to have to commit to simplifying diagrams the complex relationships which do exist or which might be made to exist both within and between the public and private sectors. The diagrams

1. For a useful collection of papers see F.E. Emery, ed., Systems Thinking, Penguin Modern Management Readings, Penguin Books, Harmondsworth, 1969.

have changed considerably and many times as more information has become available, more ideas generated, and more procedures tested. The diagrams presented here represent only the current stage of conceptualisation; they may well be superseded. Nevertheless they do provide an organised framework which, we hope, makes presentation clearer and strategic management choices easier to identify and discuss. However, the six procedural systems described in sections 3 to 8 of this paper are intelligible on their own should the reader wish to move straight to them.

Figure 1 is a portrayal of the rural plan management system described in this paper. The boxes are used to represent processes, controls, and procedures. The two black boxes represent the public sector and private sector production processes of rural development and the black lines connecting them represent resource flows. (This resource flow part of the diagram is incomplete for the sake of simplicity). The plain boxes represent the "controls" or loci of decision-making which regulate activities in the process boxes. The six coloured boxes represent procedural systems inserted into the basic control and process system in order to improve the productivity of the rural process by enhancing the quality of decisions made by the control systems. These six procedural systems constitute the rural plan management system presented in this paper.

Some elaboration of the processes, controls and procedures should help further to clarify the diagram.

First, the rural development process is represented by the thick black boxes and lines. These stand for the production (broadly defined), marketing and infrastructural activities of rural development. The upper box represents the public sector process and the lower box the private sector process. The physical outputs of the public sector process become inputs to the private sector process in the lower box.¹

1. Presented thus, the diagram deliberately emphasises a particular view of the relationship between the public and private sectors in rural development. A mechanical analogy may help here. In a motor vehicle the energy output of the starter motor is designed to provide an input to the petrol or diesel engine, accelerating it from rest until it fires and can carry on without further assistance using its own fuel resources. The job of the starter motor has been completed once this takes place. This is a reminder of the auxiliary role of public sector activity in rural development, countering the tendency to regard public projects - research stations, crop demonstrations, credit schemes and so on - as perpetual and self-justifying activities rather than as supplementary processes useful in giving the initial acceleration to rural development but requiring phasing out and even complete dismantling or handing over to the local community once this initial function has been performed.

Second, the four uncoloured boxes in Figure 1 represent controls or loci of decision-making which regulate the nature and level of activity in the process boxes. The lines connecting these boxes do not represent resources but flows of information - instructions, requests, raw data, and so on. Each of the black rural process boxes is governed or "instructed" by a local control which is in turn connected to a higher-level control. Thus the private sector process is governed by the local private sector decision-takers, whether they are individuals, groups, or whole communities. This local-level control also has access to the national political control through formal and informal political activity. Similarly, the public sector process is governed by an area (local-level) planning control - executive officials at district or divisional levels for example - which in turn receives inputs via plan formulation procedures of various kinds, from a higher-level control, which is here termed the central planning control. This in turn receives inputs - political directives, assignments, and so on, from the national political control. Ideally the central planning control will also engage in a dialogue with the higher-level political locus of overall decision-making for the national economy.

Third, the six coloured boxes represent procedural systems inserted into the control and process system to improve the decisions made by the control systems. In the diagram it can be seen that every box receives a connection or an input from at least one other box and every box also makes forward connections (i.e. sends outputs) to at least one other box. Because of these interconnections the system of procedures is a "closed" as opposed to an "open" system. It can be seen that it is possible to travel round the system from one box to another in a generally clockwise direction. The procedures have been designed to provide the planning and control system with more comprehensive, manageable and timely information and a set of decision rules through which such information can be utilised more rapidly and effectively.

The six procedural systems are:

1. The Programming and Implementation Management System (PIM)

This centres on the public production activities close to the grass-roots levels where implementation actually occurs. As shown in Figure 2, the procedures consist of programming, monitoring and adjusting activities. These are described in section 3 of this paper.

2. The Field Staff Management System (FSM)

The procedures here relate the overall project targets and their component operation targets to work assignments broken down for individual field staff for short specific periods of time across the year. These procedures are described in section 4 of this paper.

3. Local Participation Procedures (LPP)

In achieving more rapid rural development it is necessary to receive from local communities an accurate picture of their aspirations and preferences, to benefit from their knowledge and experience of the local environment, to inform them of the implications of alternative public and private sector activities and policies, and to arouse their enthusiasm and commitment for those projects which **move** into the implementation phase following this previous dialogue on the structure of the local rural development programme. Procedures for taking into account local wishes and local knowledge and for securing local tangible commitment to the development projects are discussed in section 5 of this paper.

4. The Evaluation Review Sequence (ERS)

Evaluation is the crucial activity which **affects** the closure of the system by providing feedback between on the one hand implementation experience and its impact on local economy and society and on the other the formulation of goals, targets and projects for the next plan period by the planning control. The evaluation procedures are designed to provide feedback at four different periodicities into the plan formulation and programming systems (see figure 2). The evaluation procedures are described in section 6 of this paper.

5. Rural Research and Development (RRD)

The major objective in this area is to end the relative isolation of scientific rural production research both from the plan formulation and plan implementation processes and from the research activities in other disciplines which are necessary for the identification and design of commercially viable production innovations. The present largely exploratory state of progress in this area is discussed in section 7 of this paper.

6. Plan Formulation Procedures (PFP)

Plan formulation here means considerably more than the production of a plan document. The term is used to refer to analyses and the decisions based upon them which allocate public sector resources between alternative uses, or which create incentives or penalties for private sector resource allocation decisions.

In figure 2, three of the procedural boxes - for Programming and Implementation Management, the Evaluation Review Sequence, and Plan Formulation Procedures - have been exploded to show management loops and periodicities. This diagram shows how it is possible to travel round several different feedback loops at different times. It also indicates points at which the system can be entered. (For a discussion of points of entry see section 9 of this paper).

The six procedural systems will now be described in turn.

3. THE PROGRAMMING AND IMPLEMENTATION MANAGEMENT SYSTEM (PIM)

The PIM system has three components:

- an annual programming exercise (APE)
- a monthly management meeting (MMM)
- a monthly management report (MMR)

(i) The Annual Programming Exercise

A decision is taken as to which projects should be programmed. For each project in turn, those staff members directly concerned with implementation are invited to a meeting. The person responsible for the project at Ministry level also attends. Those present may be from one or several ministries, and from divisional, district, or even provincial level depending on where implementation responsibilities lie.

Discussion starts with an examination of the objectives of the project. Often these are not clear and sometimes the value of the project may be questioned. In such cases follow-up action may be decided and the meeting adjourned. When there is agreement on objectives, their desirability, and the potential of the project for achieving them, detailed programming can begin.

Component operations in the project are identified and listed in approximate sequence showing duration, preferably on a blackboard visible

to all participants. A checklist of operations in the most commonly occurring projects has been prepared (Belshaw 1972b) and can be used at this stage. As agreement is reached, an Annual Phasing Form (APF) is completed, listing each operation, the officer responsible for it, the resources required, the target start and completion dates, and the completion indicator for the operation. The planned time allowance and completion indicators are then transferred to an Annual Programming Chart (APC) which presents the programme of operations in a bar chart. Monthly targets may be entered on it.

Each participant leaves the meeting with an APF or APC completed to present a realistic phased programme of operations which he has helped to prepare and to which he consequently feels committed.

(ii) The Monthly Management Meeting

After programming has taken place, management meetings of those responsible for implementation are arranged at monthly intervals. (The intervals can be shorter or longer according to the nature of the project, but in the context of the Kenya SRDP less than a month would be too much of a burden, while more than a month would weaken the operational control and incentive aspects of the system). The officer responsible (the Area Coordinator in the Kenya SRDP) checks through the APCs and asks about all the operations which should be in hand or which should have been completed. The operations are then entered on the bars on the APC either in green for on time or on or above target, or in red for behind time or below target. Remedial action is discussed and decided. This meeting focusses discussion on practicalities, timing and action, and also provides an incentive, through collegiate control, for staff to perform adequately and on time the operations for which they are responsible.

(iii) The Monthly Management Report

The word "report" is misleading since this is an operational control device for securing action, not for communicating routine information. The report has two main sections. The first, the "Progress and Action Summary", is a short sharp summary of the position and of action required: for each project it lists the operations which are or should be "active", the target for the month's end, the actual achievement, whether the operation is on time, the remedial action required if it is not on time, and who should take that action. The persons from whom action is requested have their initials

circled in red on the copies they receive so that they focus quickly and do not have to read the whole report. The second section of the report elaborates on what has happened and specifies more exactly what needs to be done.

The report is unusual in being sent simultaneously to different departments at four or five different levels in government - ministry headquarters, province, district, division, and sometimes location. The normal lengthy process of feeding upwards through district and province is thus avoided, though those levels are kept informed.

The reports enable recipients to keep their APCs up-to-date each month. For the Kenya SRDP, all the charts are displayed in an operations room in the Ministry of Finance and Economic Planning, so that the reported state of implementation of programmes can be appreciated at a glance. Each Area Coordinator maintains a similar field operations room for his area with charts and maps.

The PIM system has been tested for a year and a half and is now (December 1972) operating in six SRDP areas. A fuller description and evaluation of the system is given in a separate paper (Belshaw and Chambers 1972b). The system has been found to work and to generate substantial benefits in terms of increased effectiveness of operation.

The PIM system is separable from the other sub-systems and can be introduced independently of or in advance of the complete plan management system. Indeed, it facilitates the latter by improving the knowledge of implementation performance and of bottlenecks without which accurate plan formulation is difficult. It can therefore be regarded as the core component of the whole system.

4. FIELD STAFF MANAGEMENT SYSTEMS (FSM)

The FSM systems are concerned with work management for field staff. In their origins and operation they are closely related to the PIM system. At an early stage the application of the PIM system to agricultural programmes revealed a problem of resource allocation in the use of agricultural extension workers' time: targets for extension performance determined at the district level turned out to be seriously, even wildly, unrealistic at the grass-roots level of the location. In one month, in one location, the district targets appeared to require 725 man-days of work when, with existing staff, only 153 man-days were available. In other months, the

man-days required fell to less than a quarter of those available (Belshaw and Chambers, 1971: Appendix D). Attempts to devise procedures to overcome this problem led down to the location as the administrative level at which most work targets might best be set. Over more than a year various experimental procedures have been tried in one SRDP area (Ilibere Division) for agricultural extension staff, and further systems are being worked out for staff concerned with livestock.

Several problems were faced in devising an effective system of work management for agricultural extension. As is commonly the case with junior field staff, personnel were widely scattered and difficult to supervise. Performance was difficult to monitor. Standardised performance targets were liable to be unrealistic because of variations in size of area, ecology, crops, numbers of farms, and similar factors. Realistic work programmes had to vary according to the weather, and, once crops were in the ground, according to the acreages planted. In circumstances such as these, it is important for staff to take part in programming their own work and setting their own targets, both to make use of the local knowledge which only they possess and to encourage personal commitment.

The FSM system for crop extension has two partially interlocking components: a monthly management meeting (not the same as that for the PIM); and a record book system.

(i) The Monthly Management Meeting

The procedures which have been tested centre on a monthly meeting at the location level. This is attended by the Junior Agricultural Assistants (JAAs), each typically responsible for a sub-location, the Location Agricultural Assistant (LAA) in charge of the location, and the Assistant Agricultural Officer (AAO) in charge of the division. The basic procedure makes use of three forms:

Daily Activity Records: These are entered daily by JAAs during the month and are brought to the meeting. The LAA and AAO check and discuss the record with each JAA as he arrives. The performance totals reported by the JAAs are entered on the Staff Activities Summary which has a column for each extension agent and spaces to show planned and actual performance. The AAO, LAA and JAAs then plan for the next month using the

Location Planning Sheet which shows the number of work days available for each JAA. Extension activities are then listed below and placed in an order of priority. Some of these are derived from the operations and targets set during the Annual Programming Exercise and recorded on the Programming Charts (See PIM above). The original targets and the time required to fulfil them are then discussed, modified if necessary, broken down and entered for each JAA until all the time available has been used up. These performance targets are then transferred by the LAA to the Staff Activities Summary for the next month, and by the JAAs to their Daily Activity Records for next month, providing them with an agreed set of instructions and priorities to which daily reference can be made. These are then taken away by the JAAs and entered up each day until the next monthly meeting.

(ii) The Record Book System

Coupled to the work planning are some recording devices: The farmers visited by the extension worker have a record book in which date, purpose of visit and advice given are recorded by the extension worker on each visit. As an optional part of the system the extension workers keep a duplicate book in which they record the same information, one copy being sent to their senior officer for his information. A third book contains a continually updated list of farmers visited with dates of visits, i.e. a farm visit register.

The system is still in the early stages of implementation and it is too soon to make any definitive evaluation. There are obvious dangers of formalism with any set of procedures such as this. However, some benefits have been noted. The record book system provided early feedback on the extent to which extension workers concentrated on a small group of top farmers, enabling their supervisors to instruct them to spread their visits more widely and then monitor the reported spread of contact that followed. Also, farmers themselves pressured extension workers to give them record books, which further motivated them to expand their clientele to include less-influential farmers. Thus the system can be used to improve the equity aspect of the distribution of extension services. Further possible uses in improving the ease and quality of upward reporting and in providing a framework for farm management investigations are being explored.

The variation in tasks and situations between field workers in different geographical areas and in different departments are so great

that it is unlikely that in its details any one system of work management can or should be universally applied. It is not the details of any such system but the principles which are incorporated in its design which are important. As they have emerged from the experience to date, the main principles can be stated as:

- (i) the use of a method for determining the numbers of work days available, listing activities, setting priorities between them, and allocating time for their performance, with quantified targets where possible, throughout the work period.
- (ii) the setting of work targets as far as possible by staff themselves in conjunction with their supervisor. The degree of discretion of subordinate staff should vary with the non-routineness of their tasks and their variability (within one supervisor's area, and over time).
- (iii) care should be taken in using reported performance in a disciplinary manner since this may generate false reporting.
- (iv) systems should be kept simple.

Whereas PIM is adaptable to a wide range of programmes and circumstances, the particular system devised for agricultural extension staff management is more organisation - and situation-specific. Field staff management systems need to be devised ad hoc for particular departments and even for particular field situations, using the principles listed above and making modifications in the light of experience as necessary.

While FSM systems can and do link in with the PIM system, they can be implemented independently of PIM, if desired.

5. LOCAL PARTICIPATION PROCEDURES

"Local participation" is commonly used in three different senses: to refer to participation (i) by government field staff, or (ii) by local people, or (iii) by both. It is used here to refer to participation by local people or their representatives, including the procedures and institutions through which they interact with government staff.

For at least two decades local participation in plan formulation and implementation has been a major concern in much of the third world. Innumerable attempts have been made, particularly by Community Development

workers, to involve local people in plan formulation, in community activities and in self-help projects. Experience has been mixed. Discussion has often been obscured by words like "mobilisation" which can and do mean different things to different people. A generalised ideological preference for "participation" and "mobilisation" has not always been combined with careful empirical work on defining the respective roles of government field staff and local people; nor have the distortions to projects which can result from their capture by local interest groups always received the attention they deserve. Moreover there are technical difficulties in local participation in plan formulation; and Oyugi has gone as far as to argue that the idea that the people should be involved in planning and administration, though noble, is not realistic (1971:4). What is required is more careful and specific analysis and statements, breaking down general terms into smaller components and devising procedures appropriate to particular situations.

Three kinds of participation can be separated out as important for more effective rural plan management: taking account of local wishes; making use of local knowledge; and securing local contributions. Appropriate procedures for these must vary widely according to the local institutional structures for local participation than for any of the other five systems. Also, at the time of writing (December 1972) the relevant experience in the SRDP has not yet been examined. Some general principles can, however, be suggested:

(i) Taking account of local wishes

Local wishes in plan formulation and implementation can be mediated through existing representative institutions, or through any special institutions which can be created. In the first round of SRDP planning, consultation was limited by pressure of time on officials, by the absence of an established procedure, perhaps by a fear that local wishes (for schools and health facilities) would conflict with national priorities (such as agricultural production and roads), and in most areas at that time by the lack of an effective functioning forum for discussion with local leaders. District Development Committees consisted of officials only and, except in Nyanza Province, the District Development Advisory Committees, which included Members of Parliament and other local leaders as well as officials, existed in little more than name. In East Africa as a whole

there was a tendency for local development committees in their first few years to suffer from lack of definition of responsibility, and domination either by civil servants to the exclusion of politicians (as in Kenya and sometimes Tanzania) or by politicians to the exclusion of civil servants (as with the district development fund in Uganda) (see Gertzel 1970 and Kenya Government 1971 for Kenya; Collins 1970 for Tanzania; and Kirunda 1971 for Uganda). The notable exception in Nyanza Province in Kenya provides the key to the successful operation of such bodies for the purposes of local participation as here defined. There, the District Development Advisory Committees were requested from the provincial level to make recommendations about the detail of development programmes, including the siting of water supplies and priorities for road development. As it became evident that important decisions were taken in the committees, so they became effective in bringing together civil servants and political leaders and in conducting their business. With this example in mind, we limit ourselves at this stage to stating the principle that local wishes may best be taken into account through established institutions with responsibilities which are clearly defined and real in the sense that decisions taken through them lead to tangible results.

(ii) Making use of local knowledge

Local knowledge can be used in both Rural Research and Development and the Plan Formulation Procedures. The people living in an area usually have a wealth of knowledge about soils, vegetation, climate, rainfall and farming systems, besides of course, social and political organisation. They may have their own ecological categories which will be useful for both research and plan formulation purposes. Snags in projects, unforeseen by planners, may be very obvious to the people who live in an area. For these reasons, procedures for obtaining relevant local knowledge are required and their detailed design should enable this information to be used in Rural Research and Development and in Plan Formulation Procedures.

(iii) Securing local contributions

Securing local contributions through self-help activity, whether in the form of subscriptions of money or donations of labour, is widely considered desirable on economic, social and political grounds: economic because it mobilises private resources which might otherwise have lain dormant; and social and political because of the value set on communal

cooperation in achieving a common purpose. But plan formulation and implementation on the one hand and self-help on the other are uneasy partners. The problems that arise are well known, and include self-help capital works (schools, health centres etc.) without recurrent finance or staff, poor siting or design of facilities, disruption or distortion of technical programmes (Holmquist 1970, Carruthers 1969), authoritarian and income-regressive methods of fund collection, the failure of self-help labour to materialise, shortfalls in subscription collections, and delays in the supply of official inputs.

As one means of improvement, an extension of the principle of joint programming used in the PIM system can be suggested for local self-help projects. A proposal on these lines has been devised for village projects, such as school classrooms or health centres, in Botswana. In brief, a joint programming meeting was to be held between officials, village leaders, and if relevant the building contractor. The programming exercise was to take place in the village school classroom using its blackboard. As with PIM, activities were to be identified and listed, responsibilities agreed, and target phasing indicated on bar-charts. Progress was to be monitored each month by community development staff, and a monthly meeting held at the district level to review progress and to decide remedial action if required. The system was designed to obtain in public the commitment of all the persons concerned to carrying out their tasks; it also provided for feedback on progress. The principles, similar to those of PIM, appear generally applicable to any self-help project which requires official inputs as well as those of the local community.

It is evident from this brief presentation that LPP procedures are less developed and less tested than those for the other five systems. However, numerous pragmatic approaches have been made in this field over the years and it is hoped to analyse and systematise some of this experience with the object of devising an adaptable and replicable procedural system.

6. THE EVALUATION REVIEW SEQUENCE

As Figure 2 shows, the Evaluation Review Sequence is closely linked with the PIM and the Plan Formulation Procedures. The PIM generates much of the information which is organized into the sequence of reviews, which then feed back into (re)programming, estimates, replanning, and the perspective plan. In normal plan management, these links are seriously

neglected, with the result that the annual estimates (which are the main plan formulation operation) are prepared without the benefit of a systematic appraisal of experience. At the same time, the introduction of an evaluation review sequence is not costless: it requires either additional resources in manpower, or additional work from existing manpower, or a re-allocation of work between activities. With this in mind, the procedures have been made simple and the original formats of the reviews have been considerably reduced in length and detail.

(i) The Annual Implementation Review (AIR)

The AIR summarises the main practical lessons learnt in the implementation of projects over the first ten to twelve months of the financial year. Its purposes are:

- (a) to improve programming and implementation for the following year. The Annual Programming Exercise (APE) follows on soon after the AIR;
- (b) to enable local-level officers to summarise implementation problems and to present these to headquarters for remedial action where appropriate;
- (c) to make it possible, through comparison of patterns of implementation experience in different areas, for general problems to be discerned which can only be tackled at the centre.

The main sources for the AIR are the Annual Programming Charts which record actual as against programmed performance and the set of monthly reports which are part of the PIM system. The AIR concentrates on the experience of implementation of projects, leaving the question of their desirability to the Plan Evaluation Review. The contents of the AIR are:

- A Project Summary (a single page chart)
- B Progress Summary (an achievement summary for each project)
- C Review of Project Implementation (across all projects)
- D Overall Performance and Strategy
- E Check-list of Projects for Programming for the next Financial Year.

The more elaborate contents originally proposed for the AIR together with a completed example for Ibere Division for 1971/72 are given in Belshaw 1972a.

(ii) The Plan Evaluation Review (PER)

The Annual Implementation Review deals with implementation, mainly within the public sector. In contrast, the Plan Evaluation Review deals mainly with the costs and benefits of projects, the benefits being assessed in the private sector. Its main objectives are:

- (a) to make cost-effectiveness and/or cost-benefit evaluations of projects possible, enabling comparisons between projects of the same type in different areas, and between projects of different types in the same area, and between projects of different types generally, with a feedback to policy;
- (b) to identify gaps in information for such evaluation so that the value of filling them can be appraised;
- (c) to provide the Area Coordinator (in the SRDP) with a procedure and opportunity for evaluating the impact of individual projects and of the strategy and for proposing and justifying modifications and additions for the future, feeding into the annual estimates and periodic replanning procedures;
- (d) to present senior officials with an evaluation upon which decisions for abandonment, modification or replication can be based.

The Plan Evaluation Review, after simplification, has these contents:

- A The Project List (from the AIR)
- B Project Experience (project by project)
Implementation Problems - Development Effects - Subjective Assessment - Experimental Content¹ - Replicability¹ -
Project Revision and Requests for Estimates for the
Following Year
- C Research
- D Preliminary Review of the Strategy, setting the strategy
summary in the original plan against this experience.

1. The 'Experimental Content' and 'Replicability' sub-sections are required for SRDP reports since a reasonable proportion of projects are intended to be experimental. In the normal district programme, however, these sub-sections would not be necessary.

For a description of the more elaborate review originally proposed, see Belshaw and Chambers 1972a.

(iii) The Interim Implementation Review (IIR)

The Interim Implementation Review is a brief version of the Annual Implementation Review. Its main purpose is through summarising progress and problems during the first six months of the financial year, to improve and speed implementation during the remaining period. A secondary purpose is to provide field staff with a last opportunity to feed in suggestions for revision in project design which have implications for the financial estimates and staff postings for the next financial year, which is still some 5-6 months away. The emphasis is on individual projects rather than on the strategy. The proposed contents of the IIR are:

- A Project Summary
- B Progress Summary (project by project)
- C Review of Project Implementation (across all projects)
- D Project Modifications (if any) with justification and implications for the Annual Estimates.

The functions of these reviews can be appraised by examining Figure 2. It will be noted that the implementation reviews (AIR, IIR) are very closely linked with the PIM system, while the Plan Evaluation Review is linked with Annual Estimates, the Replan and the Perspective Plan Frame. In the absence of a Plan Evaluation Review, the implementation reviews can link direct to the Annual Estimates.

7. RURAL RESEARCH AND DEVELOPMENT

A major objective in introducing a management system approach into this area is to end the isolation of applied scientific research (crop and livestock production research in particular) from the process of formulating rural development plans. Because of this isolation, some of the results of scientific research have appeared irrelevant to problems or opportunities on the ground, while research claims to have generated practical procedures have often passed unnoticed and untested by planners. An example is the considerable research effort in East Africa devoted to crop water balance methods of determining potential crop productivities and preferential location patterns, research which was unknown to rural planners and which might have been considerably modified or even abandoned had there been

effective communication between researchers and planners at an earlier stage. What is required is better management on both sides and better communication between them: on the plan formulation side through the clarification of development priorities in order to adjust the emphases in applied research programmes; and on the research side through a field trial or pilot project phase which will yield tested and usable research results. These must then be described and communicated in a manner which will influence key resource allocation decisions.

In the Kenya SRDP exploratory work has recently started on procedures for integrating rural research and development (R and D) activities, especially natural resource appraisal, agricultural production research and market research, within the framework of rural plan formulation and revision. An important requirement is the cycling of initial research findings through the implementation-cum-evaluation loop. This implies greater use of small pilot projects, farm-level trials, trial marketings etc., in order to test these results under realistic production and marketing conditions. Preliminary work on control procedures for rural R and D activity has begun in 1972 in one SRDP area (Mbere), using a multi-disciplinary committee embracing the complete range of expertise required to design, test and implement a viable commercial production activity. This committee is focussing on crop diversification policy for a marginal low-income agricultural area. A preliminary list of some 30 potential cash crops suitable for the area has been compiled. Those crops which remain on the list after preliminary market appraisal will be subject to agronomic experiments and farm trials with test marketing.

Three other aspects of R and D activity are being examined. These are:

- (i) Practical procedures for determining agricultural research priorities in relation to the potential and problems of local rural areas;
- (ii) The integration of farm economics analysis with agricultural research on the one hand and agricultural extension work on the other. The focus here is evidence concerning relative farm-level profitability of alternative crop and livestock activities. Evidence of low relative profitability implies a low priority in current agricultural extension policy. Questions must then be asked about the chances of a research input on the activity in question generating technical advances which would enhance its profitability, about

the levels of profitability which might be expected, and about the return (in terms of social benefits or other criteria) to the employment of scarce research resources on this activity compared with the return to their use in other research projects.

(iii) The use of soil survey and ecological zone classifications based on various alternative criteria for the design of farm management and agricultural sample surveys. Existing work on climate and crop ecological zones will be compared with the results of a major soil and land use survey which started in the area in 1972. A further relevant line of enquiry which it is hoped to take further is the accuracy and usefulness of local people's perceptions of the relative advantages of alternative sites for settlement and agriculture, and of their methods of identifying and classifying environmental characteristics.

While the development and testing of a rural R and D system is at an exploratory stage, the early indications are that a multi-disciplinary research committee approach, perhaps for each major ecological zone, is feasible and useful. The system has not yet been operating long enough for research results to be fed into the plan formulation process though given the presence of planners on the research committee, this should not present any serious difficulties.

8. PLAN FORMULATION PROCEDURES

"Plan formulation" is used here to refer to the processes of analysis and decision-making which allocate public sector resources between alternative uses or which through incentives or penalties influence private sector resource allocation decisions. It is by no means limited to, and indeed may not involve, the production of a plan document.

Plan formulation for rural areas can be described in terms of four different planning approaches. (See Belshaw 1972c and Chambers 1972).

(i) The budget process: The major allocation decisions are made continuously through the public sector budgetary process. This tends to be routine and ritualistic and rarely involves radical reappraisal or systematic evaluation of past experience.

(ii) 'Shopping lists': The "do-it-yourself" approach using local-level officials and leaders to suggest development projects, albeit a low-cost method, usually leads to the production of low-quality proposals. The shopping lists of capital projects which are liable to result are difficult or impossible to handle at the centre and local-level planners are disillusioned when it becomes clear that no action will be taken on their proposals.

(iii) Resource inventory plans: A conventional high-cost approach aimed at a high quality plan is to attempt substantial data collection, with the stress on the appraisal of natural resources, aiming at a plan for optimal resource allocation. In practice such approaches have often foundered before implementation and are in any case very expensive in high-level manpower. It was with this approach in mind that a draft Rural Planning Manual (Belshaw et al. 1971) was prepared for the Kenya Government's Ministry of Finance and Economic Planning.

(iv) A progressive replanning approach: This is a middle way between the three preceding approaches, consisting of a phased introduction of a complete plan management system. (For the basic rationale of this system see Belshaw 1972c, Appendix). It does not focus on the production of a single plan document, although an outline plan document may be produced at an early stage. The initial planning operation concentrates on (a) a sharpening of objectives and implementation in the use of those resources already committed in the rural area in question by means of the introduction of the PIM system selectively for the more important programmes and projects, (b) identifying key constraints in the production infrastructure and relating these both to local private resources (self-help labour, funds etc.) and to any grants the allocation and application of which have been devolved to the administrative area, and (c) collecting information during the course of controlled implementation which will improve the quality of the next replanning phase.

The essence of the progressive replanning approach is gradualism, phasing introduction of procedures according to the planning and management capability that is available. A possible sequence for introduction is illustrated in Figure 3. The start point in this example is an Annual Programming Exercise, given previous budget allocations, at the start of a financial year (FY1) leading in to monthly meetings and reports for monitoring and operation control (the PIM system). In FY2 the Annual

Implementation Review from FY1 is used to improve the Annual Programming Exercise and also the budget procedures for FY3. In FY3 systematic economic appraisal also feeds in to the budget procedures which conclude (in this example) with a two year action plan. After one year's implementation experience with that plan, a Plan Evaluation Review feeds in to the following year's budget procedures and replan. Obviously many variations are possible. Conventionally - inclined system designers may be tempted to introduce a formal plan at an earlier stage, and one may or may not be justified. A five year outline plan, coinciding with and related to a national five year plan, may also be desirable. There is also a case for a much longer-term perspective plan, looking ahead 20 or 25 years and relating resources to population projections in order to provide a frame for the shorter-term plans.

It is suggested that action plans should always be formulated in conjunction with the budget procedures, and that plan formulation procedures should be grouped under seven heads:

- I. Essential data assembly
- II. Assessment of the current state of development, and of development trends, in relation to population growth
- III. Identification, formulation and appraisal of feasible production projects and supporting infrastructure
- IV. Production strategy selection, i.e. the mix of production projects
- V. Determination of priorities for social services
- VI. Plan appraisal, approval and final preparation as an action document
- VII. Programming and implementation.

The plan should be written up after the budget estimating procedures in order to avoid the common discontinuity between the plan and the estimates.

Procedures on these lines are being developed and tested in relation to replanning for the SERDP areas in Kenya. In the SERDP a plan document was produced for each area before the introduction of PIM. The introduction of PIM without a local plan document has not yet (December 1972) been tested though there is no reason to suppose that it would present any serious difficulties.

9. REPLICATION AND CHOICES

Presented in this brief fashion the management potential of these systems has not always been fully brought out. In subsequent papers each of the six systems will be described and analysed in more detail. In the meantime, some of the choices in introducing such systems can be made explicit. Indeed, one of the benefits of a systems approach is that choices become evident which were previously obscured. These choices can be described along three overlapping dimensions: what to include, where to start, and how complex to become.

(i) What to include

PIM = The Programming and Implementation Management System
FSM = Field Staff Management Systems
LPP = Local Participation Procedures
ERS = The Evaluation Review Sequence
RRD = Rural Research and Development
PFP = Plan Formulation Procedures

Any of the six systems could be introduced independently on its own. The first three—PIM, FSM and LPP would probably lose least through independent introduction. RRD is very weak without PFP. As Figure 2 shows, there are strong interdependencies between PIM, and ERS and PFP. Both ERS and PFP are liable to be weak unless link with PIM.

A choice of what to include is a choice of allocation of manpower resources for system development, introduction, monitoring, modification and replication. The relative benefits of the systems and their relative potentials for rural development have therefore to be appraised. It is always possible to start with one system and then gradually to add on others as feasible and desirable.

(ii) Where to start

For the Rural Plan Management System (see Figure 2), there are five main entry points:

- ENTRY 1: Programming: This is a quick entry into on-going implementation, with potential immediate benefits. Implementation is improved and feedback generated to reprogramming and later through the ERS to PTP
- ENTRY 2: Monitoring: A periodical meeting and reporting system can be introduced as a first step, but this is likely to point at once to the need for programming through Entry 1.
- ENTRY 3: Implementation Reviews: A review of implementation over a year or lesser period could be carried out as a preliminary to an Annual Programming Exercise. Although such a review would be somewhat unsystematic in the absence of a preceding APE, it should improve the quality of the following APE
- ENTRY 4: Plan Evaluation Review: This is only feasible if there has already been a plan against which performance and impact can be assessed. However, if there has been a plan and a replan is intended without delay, this point of entry could be useful
- ENTRY 5: Plan (Replan): The conventional point of entry, used in the first round of the SRDP and in many rural development situations. It has a logical obviousness which conceals the now well-known dangers of plan formulation without implementation, failures to obtain ministry approvals, delayed fund releases, lack of commitment of local-level staff, and so on.

Which point of entry is best will depend on local circumstances. Our experience suggests that Entry 1, through programming, is to be preferred. It can act like a starter motor to the whole system or to part of it, beginning with the monitoring loops, and then moving outwards through the implementation reviews to the annual estimates, and then later through the Plan Evaluation Review to the (Re)Plan and Perspective Plan Frame.

(iii) How complex to become

Throughout there are choices about the degree of complexity designed into any of the six systems. System designers are liable to strive towards an apparent perfection by adding operations, cross-checks, communication links, data requirements and meetings. But complexity has costs. Executive capacity, as argued elsewhere (Chambers 1969), can and should be

regarded as a scarce resource; demands upon it should therefore be rationed. An optimal procedural system requires sophistication in simplicity.

The choices in degree of complexity within any one system cannot always be made explicit. In practice, testing a system is likely to show up which operations can be streamlined. The FII, FSM and ERS systems described above have all been substantially simplified since their original tests though it has sometimes been necessary to resist requests that they be made more elaborate in order to elicit more information. Fairly intensive research and development is needed initially with any of these systems in order to modify and adapt according to experience and the needs of particular situations.

For replication and development of any of these systems we recommend three conditions.

First, the introduction should initially be experimental. Most procedural innovations in governments are introduced simultaneously throughout the whole organisation and without testing. However, the arguments for pilot operations with careful monitoring and evaluation apply as much to procedures as they do to development projects. The implication is that experiments should be carried out in one or more rural areas. The SIDP approach, with six areas, has the advantage of providing a range of experience which reduces the dangers of findings being distorted by individual personalities or other peculiar circumstances.

Second, the principles lying behind the systems outlined above are more important than their details, although when it comes to implementation the procedural detail is crucial. The main principles as they have been developed and adopted are:

- (i) The introduction of improved management techniques for field staff, with emphasis on joint programming, joint target-setting, and individual work programmes. Some of the principles of IDO (see Humble 1967; Garrett and Walker 1969; Hordain, 1971) have been particularly useful.
- (ii) The analysis of rural plan management as a system identifying linkages and gaps and making it easier to optimise the allocation of resources (staff time in particular) between activities, emphasising programming, implementation, monitoring and evaluation and de-emphasising plan document writing.

(iii) functional reporting in which information is only collected and transmitted if it has a management function,

(iv) striving for simplicity, especially in seeking optimal ignorance through not collecting data which, even if useful, may not be worth the cost.

Third, a research and development capability is required. This may be located in a consultancy organisation, in government, in a university or in a research institute. There are arguments for and against all of these. Consultants tend to be short-term and may not fully appreciate the functioning of administrative systems in the necessary detail. Government staff are liable to interruptions and are liable to be diverted suddenly onto other work. University staff are subject to many distractions and find it difficult to meet government deadlines. Research institutes, combining independence of the daily demands of government work with a freedom from the many commitments of university teaching staff, may be the least unsatisfactory location. But more important, perhaps, is the interest of the research and development staff in this sort of work, especially since it does not fall within the confines of any conventional discipline. The literature and techniques of management are perhaps more relevant than those of any other field, but they require adaptation to the circumstances of rural development. A combination of disciplines and a readiness to improve and learn from experience appear important. Certainly in our own case we have come to this work from different backgrounds (agricultural economics and public administration respectively) and have learnt and have had to learn a great deal. It is hoped that others, including people with other backgrounds, will also make management systems for rural development their concern and that this paper will be of some help in providing them with a starting point.

REFERENCES

- Belshaw, Deryke (1972a) "The Annual Implementation Review: Objectives, Structure and Content", (mimeo), Institute for Development Studies, University of Nairobi.
- Belshaw, Deryke (1972b) "Special Rural Development Programme: a Check-list of Operations for Major Rural Programmes", (mimeo), Institute for Development Studies, University of Nairobi.
- Belshaw, Deryke (1972c) "An Outline of Procedures for District Development Planning in Kenya", (mimeo), Institute for Development Studies, University of Nairobi.
- Belshaw, D.G.R., T.J. Bjorlo and M.M. Shah (1972) "A Hierarchical Systems Formulation of the Rural Development Process in Developing Countries", (mimeo), University of Nairobi.
- Belshaw, Deryke and Robert Chambers (1971) "Programming, Operational Control and Evaluation for Rural Development Plans", (mimeo), Institute for Development Studies, University of Nairobi, Staff Paper No. 111.
- Belshaw, Deryke and Robert Chambers (1972a) "The Annual Evaluation Review", (mimeo), Institute for Development Studies, University of Nairobi.
- Belshaw, Deryke and Robert Chambers (1972b) "PIM: A Practical Management System for Rural Development Programmes and Projects", (mimeo), Institute for Development Studies, University of Nairobi.
- Belshaw, Deryke, Milan Bedi, Robert Chambers and Jess Hungate (1971) "Rural Planning Manual", (mimeo), (various drafts), Institute for Development Studies, University of Nairobi.
- Carruthers, I.D. (1969) "Issues in Selection and Design of Rural Water Projects", (mimeo), Institute for Development Studies, University of Nairobi. Discussion Paper No. 88.
- Chadwick, George (1971) A Systems View of Planning: Towards a Theory of the Urban and Regional Planning Process. Pergamon Press, Oxford.
- Chambers, Robert (1969) "Executive Capacity as a Scarce Resource", International Development Review, Vol. 11, No. 2, June.

- Chambers, Robert (1972) "Planning for Rural Areas in East Africa: Experience and Prescriptions", The African Review, Vol. 1, No. 3, January. (Also Discussion Paper No. 119, Institute for Development Studies, University of Nairobi).
- Collins, Paul (1970) "The Working of the Regional Development Fund: a Problem in Decentralization in Rural Tanzania", (mimeo), paper to the Universities of East Africa Social Science Conference, Dar es Salaam.
- Deery, F.D., ed., (1969) Systems Thinking, Penguin Books, Harmondsworth.
- Garrett, John and S.D. Walker (1969) Management by Objectives in the Civil Service, CAS Occasional Paper No. 10, HMSO, London.
- Gertzel, Cherry (1970) "The Provincial Administration and Development in Kenya 1965-68", (mimeo), paper to the Universities of East Africa Social Science Conference.
- Meyer, Judith, Dunstan Ireri and Jon Morris (1971) Rural Development in Kenya, East African Publishing House, Nairobi.
- Holmquist, Frank (1970) "Implementing Rural Development Projects", in Goran Hyden, Robert Jackson and John Okumu, eds., Development Administration: the Kenyan Experience, Oxford University Press, Nairobi.
- Humble, John W. (1979) Improving Business Results, McGraw-Hill, New York.
- Kenya Government (1971) Report of the Commission of Enquiry (Public Service Structure and Remuneration Commission) 1970-71 (The Ndegwa Commission Report), Government Printer, Nairobi.
- Kenya Government (1972) 1972/73 Estimates of Recurrent Expenditure of the Government of Kenya, Government Printer, Nairobi and Development Estimates for the Year 1972/73, Government Printer, Nairobi.
- Kulp, Earl M. (1970) Rural Development Planning: Systems Analysis and Working Method, Praeger, New York.
- Kirunda, Charles R.A. (1971) "Problems of Implementing the Rural Development Programme in Ankole District, Uganda, during the 1969/70 Financial Year", (mimeo), Department of Political Science and Public Administration, Makerere University, Kampala.

McGregor, D. (1960) "Theory X and Theory Y" reprinted in D.S. Pugh, ed., Organization Theory, Penguin Books, Harmondsworth, 1971 from D. McGregor, The Human Side of Enterprise, McGraw-Hill.

Moris, J.R. (1972) "Administrative Authority and the Problem of Effective Agricultural Administration in East Africa", The African Review, Vol. 2, No. 1, June.

Nellis, J.R. (1972) "The Administration of Rural Development in Kenya", East Africa Journal, Vol. 9, No. 3, March.

Ojugi, W. Ouma (1971) "Local Participation in Rural Planning and Administration", (mimeo), Institute for Development Studies, University of Nairobi.

Reddin, W.J. (1971) Effective MBO, Management Publications Limited, London.

Waterston, Albert (1968)

FIGURE 2: MANAGEMENT LOOPS AND PERIODICITIES IN THE RURAL PLAN MANAGEMENT SYSTEM

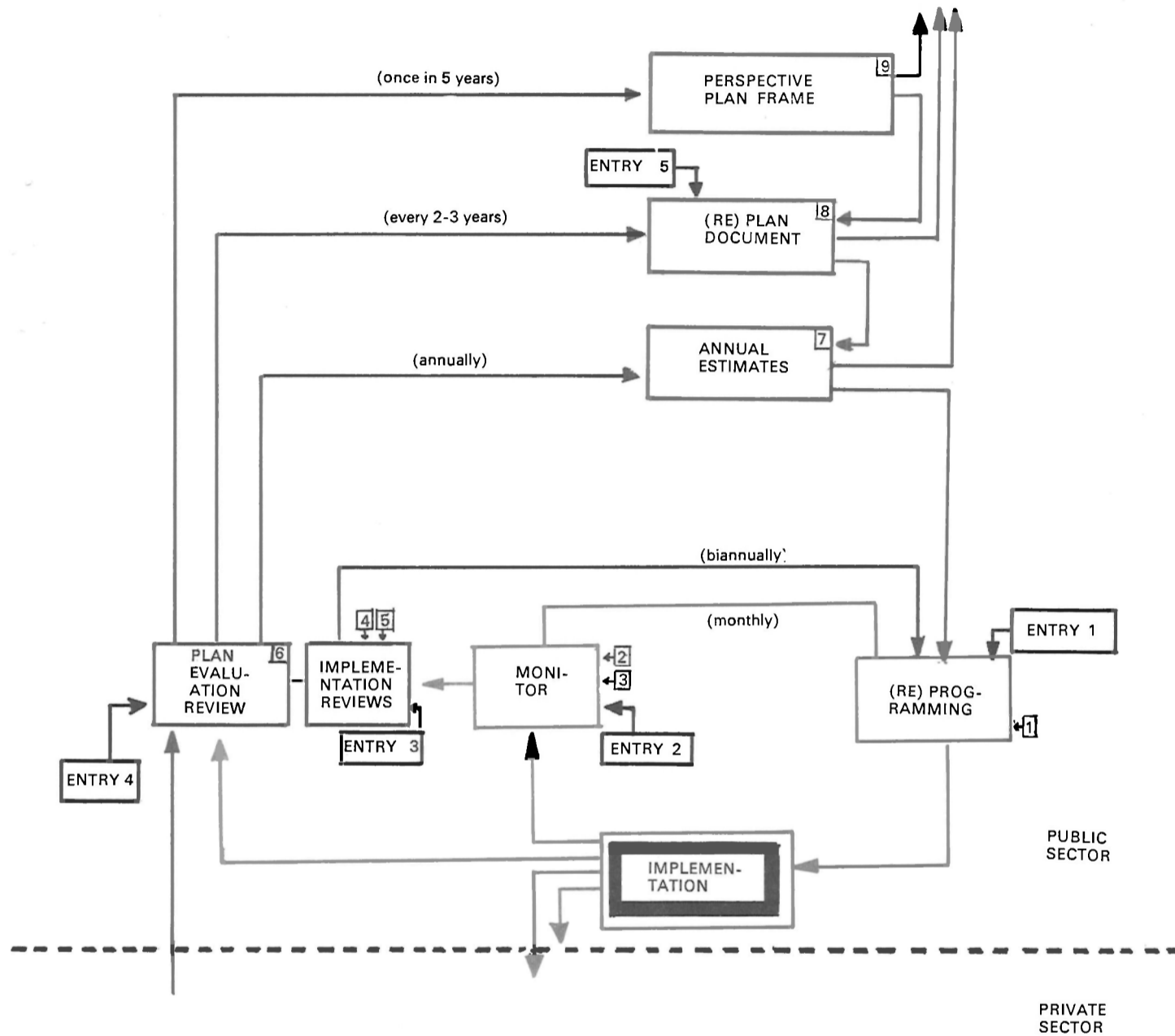

- KEY:**
- Programming and Implementation Management System (PIM)
 - 1. Annual Programming Exercise (APE)
 - 2. Monthly Management Meeting (MMM)
 - 3. Monthly Management Report (MMR)
 - Evaluation Review Sequence (ERS)
 - 4. Annual Implementation Review (AIR)
 - 5. Internal Implementation Review (IIR)
 - 6. Plan Evaluation Review (PER)
 - Plan Formulation Procedure (PFP)
 - 7. Annual Estimates Exercise (AEE)
 - 8. (Re)plan (REP)
 - 9. Perspective Plan Frame (PPF)

(ii) 'Shopping lists': The "do-it-yourself" approach using local-level officials and leaders to suggest development projects, albeit a low-cost method, usually leads to the production of low-quality proposals. The shopping lists of capital projects which are liable to result are difficult or impossible to handle at the centre and local-level planners are disillusioned when it becomes clear that no action will be taken on their proposals.

(iii) Resource inventory plans: A conventional high-cost approach aimed at a high quality plan is to attempt substantial data collection, with the stress on the appraisal of natural resources, aiming at a plan for optimal resource allocation. In practice such approaches have often foundered before implementation and are in any case very expensive in high-level manpower. It was with this approach in mind that a draft Rural Planning Manual (Belshaw et al. 1971) was prepared for the Kenya Government's Ministry of Finance and Economic Planning.

(iv) A progressive replanning approach: This is a middle way between the three preceding approaches, consisting of a phased introduction of a complete plan management system. (For the basic rationale of this system see Belshaw 1972c, Appendix). It does not focus on the production of a single plan document, although an outline plan document may be produced at an early stage. The initial planning operation concentrates on (a) a sharpening of objectives and implementation in the use of those resources already committed in the rural area in question by means of the introduction of the PIM system selectively for the more important programmes and projects, (b) identifying key constraints in the production infrastructure and relating these both to local private resources (self-help labour, funds etc.) and to any grants the allocation and application of which have been devolved to the administrative area, and (c) collecting information during the course of controlled implementation which will improve the quality of the next replanning phase.

The essence of the progressive replanning approach is gradualism, phasing introduction of procedures according to the planning and management capability that is available. A possible sequence for introduction is illustrated in Figure 3. The start point in this example is an Annual Programming Exercise, given previous budget allocations, at the start of a financial year (FY1) leading in to monthly meetings and reports for monitoring and operation control (the PIM system). In FY2 the Annual

Implementation Review from FY1 is used to improve the Annual Programming Exercise and also the budget procedures for FY3. In FY3 systematic economic appraisal also feeds in to the budget procedures which conclude (in this example) with a two year action plan. After one year's implementation experience with that plan, a Plan Evaluation Review feeds in to the following year's budget procedures and replan. Obviously many variations are possible. Conventionally - inclined system designers may be tempted to introduce a formal plan at an earlier stage, and one may or may not be justified. A five year outline plan, coinciding with and related to a national five year plan, may also be desirable. There is also a case for a much longer-term perspective plan, looking ahead 20 or 25 years and relating resources to population projections in order to provide a frame for the shorter-term plans.

It is suggested that action plans should always be formulated in conjunction with the budget procedures, and that plan formulation procedures should be grouped under seven heads:

- I. Essential data assembly
- II. Assessment of the current state of development, and of development trends, in relation to population growth
- III. Identification, formulation and appraisal of feasible production projects and supporting infrastructure
- IV. Production strategy selection, i.e. the mix of production projects
- V. Determination of priorities for social services
- VI. Plan appraisal, approval and final preparation as an action document
- VII. Programming and implementation.

The plan should be written up after the budget estimating procedures in order to avoid the common discontinuity between the plan and the estimates.

Procedures on these lines are being developed and tested in relation to replanning for the SRDP areas in Kenya. In the SRDP a plan document was produced for each area before the introduction of PIM. The introduction of PIM without a local plan document has not yet (December 1972) been tested though there is no reason to suppose that it would present any serious difficulties.

9. REPLICATION AND CHOICES

Presented in this brief fashion the management potential of these systems has not always been fully brought out. In subsequent papers each of the six systems will be described and analysed in more detail. In the meantime, some of the choices in introducing such systems can be made explicit. Indeed, one of the benefits of a systems approach is that choices become evident which were previously obscured. These choices can be described along three overlapping dimensions: what to include, where to start, and how complex to become.

(i) What to include

PIM = The Programming and Implementation Management System
FSM = Field Staff Management Systems
LPP = Local Participation Procedures
ERS = The Evaluation Review Sequence
RRD = Rural Research and Development
PFP = Plan Formulation Procedures

Any of the six systems could be introduced independently on its own. The first three—PIM, FSM and LPP would probably lose least through independent introduction. RRD is very weak without PFP. As Figure 2 shows, there are strong interdependencies between PIM, and ERS and PFP. Both ERS and PFP are liable to be weak unless link with PIM.

A choice of what to include is a choice of allocation of manpower resources for system development, introduction, monitoring, modification and replication. The relative benefits of the systems and their relative potentials for rural development have therefore to be appraised. It is always possible to start with one system and then gradually to add on others as feasible and desirable.

(ii) Where to start

For the Rural Plan Management System (see Figure 2), there are five main entry points:

- ENTRY 1: Programming: This is a quick entry into on-going implementation, with potential immediate benefits. Implementation is improved and feedback generated to reprogramming and later through the ERS to PPP
- ENTRY 2: Monitoring: A periodical meeting and reporting system can be introduced as a first step, but this is likely to point at once to the need for programming through Entry 1.
- ENTRY 3: Implementation Reviews: A review of implementation over a year or lesser period could be carried out as a preliminary to an Annual Programming Exercise. Although such a review would be somewhat unsystematic in the absence of a preceding APE, it should improve the quality of the following APE
- ENTRY 4: Plan Evaluation Review: This is only feasible if there has already been a plan against which performance and impact can be assessed. However, if there has been a plan and a replan is intended without delay, this point of entry could be useful
- ENTRY 5: Plan (Replan): The conventional point of entry, used in the first round of the SRDP and in many rural development situations. It has a logical obviousness which conceals the now well-known dangers of plan formulation without implementation, failures to obtain ministry approvals, delayed fund releases, lack of commitment of local-level staff, and so on.

Which point of entry is best will depend on local circumstances. Our experience suggests that Entry 1, through programming, is to be preferred. It can act like a starter motor to the whole system or to part of it, beginning with the monitoring loops, and then moving outwards through the implementation reviews to the annual estimates, and then later through the Plan Evaluation Review to the (Re)Plan and Perspective Plan Frame.

(iii) How complex to become

Throughout there are choices about the degree of complexity designed into any of the six systems. System designers are liable to strive towards an apparent perfection by adding operations, cross-checks, communication links, data requirements and meetings. But complexity has costs. Executive capacity, as argued elsewhere (Chambers 1969), can and should be

regarded as a scarce resource; demands upon it should therefore be rationed. An optimal procedural system requires sophistication in simplicity.

The choices in degree of complexity within any one system cannot always be made explicit. In practice, testing a system is likely to show up which operations can be streamlined. The FHM, FSM and ERS systems described above have all been substantially simplified since their original tests though it has sometimes been necessary to resist requests that they be made more elaborate in order to elicit more information. Fairly intensive research and development is needed initially with any of these systems in order to modify and adapt according to experience and the needs of particular situations.

For replication and development of any of these systems we recommend three conditions.

First, the introduction should initially be experimental. Most procedural innovations in governments are introduced simultaneously throughout the whole organisation and without testing. However, the arguments for pilot operations with careful monitoring and evaluation apply as much to procedures as they do to development projects. The implication is that experiments should be carried out in one or more rural areas. The SIDP approach, with six areas, has the advantage of providing a range of experience which reduces the dangers of findings being distorted by individual personalities or other peculiar circumstances.

Second, the principles lying behind the systems outlined above are more important than their details, although when it comes to implementation the procedural detail is crucial. The main principles as they have been developed and adopted are:

- (i) The introduction of improved management techniques for field staff, with emphasis on joint programming, joint target-setting, and individual work programmes. Some of the principles of IDO (see Humble 1967; Garrett and Walker 1969; Haddin, 1971) have been particularly useful.
- (ii) The analysis of rural plan management as a system identifying linkages and gaps and making it easier to optimise the allocation of resources (staff time in particular) between activities, emphasising programming, implementation, monitoring and evaluation and de-emphasising plan document writing.

(iii) functional reporting in which information is only collected and transmitted if it has a management function,

(iv) striving for simplicity, especially in seeking optimal ignorance through not collecting data which, even if useful, may not be worth the cost.

Third, a research and development capability is required. This may be located in a consultancy organisation, in government, in a university or in a research institute. There are arguments for and against all of these. Consultants tend to be short-term and may not fully appreciate the functioning of administrative systems in the necessary detail. Government staff are liable to interruptions and are liable to be diverted suddenly onto other work. University staff are subject to many distractions and find it difficult to meet government deadlines. Research institutes, combining independence of the daily demands of government work with a freedom from the many commitments of university teaching staff, may be the least unsatisfactory location. But more important, perhaps, is the interest of the research and development staff in this sort of work, especially since it does not fall within the confines of any conventional discipline. The literature and techniques of management are perhaps more relevant than those of any other field, but they require adaptation to the circumstances of rural development. A combination of disciplines and a readiness to improvise and learn from experience appear important. Certainly in our own case we have come to this work from different backgrounds (agricultural economics and public administration respectively) and have learnt and have had to learn a great deal. It is hoped that others, including people with other backgrounds, will also make management systems for rural development their concern and that this paper will be of some help in providing them with a starting point.

REFERENCES

- Belshaw, Deryke (1972a) "The Annual Implementation Review: Objectives, Structure and Content", (mimeo), Institute for Development Studies, University of Nairobi.
- Belshaw, Deryke (1972b) "Special Rural Development Programme: a Check-list of Operations for Major Rural Programmes", (mimeo), Institute for Development Studies, University of Nairobi.
- Belshaw, Deryke (1972c) "An Outline of Procedures for District Development Planning in Kenya", (mimeo), Institute for Development Studies, University of Nairobi.
- Belshaw, D.G.R., T.J. Bjorlo and M.M. Shah (1972) "A Hierarchical Systems Formulation of the Rural Development Process in Developing Countries", (mimeo), University of Nairobi.
- Belshaw, Deryke and Robert Chambers (1971) "Programming, Operational Control and Evaluation for Rural Development Plans", (mimeo), Institute for Development Studies, University of Nairobi, Staff Paper No. 111.
- Belshaw, Deryke and Robert Chambers (1972a) "The Annual Evaluation Review", (mimeo), Institute for Development Studies, University of Nairobi.
- Belshaw, Deryke and Robert Chambers (1972b) "PIM: A Practical Management System for Rural Development Programmes and Projects", (mimeo), Institute for Development Studies, University of Nairobi.
- Belshaw, Deryke, Milan Bedi, Robert Chambers and Jess Hungate (1971) "Rural Planning Manual", (mimeo), (various drafts), Institute for Development Studies, University of Nairobi.
- Carruthers, I.D. (1969) "Issues in Selection and Design of Rural Water Projects", (mimeo), Institute for Development Studies, University of Nairobi. Discussion Paper No. 88.
- Chadwick, George (1971) A Systems View of Planning: Towards a Theory of the Urban and Regional Planning Process. Pergamon Press, Oxford.
- Chambers, Robert (1969) "Executive Capacity as a Scarce Resource", International Development Review, Vol. 11, No. 2, June.

- Chambers, Robert (1972) "Planning for Rural Areas in East Africa: Experience and Prescriptions", The African Review, Vol. 1, No. 3, January. (Also Discussion Paper No. 119, Institute for Development Studies, University of Nairobi).
- Collins, Paul (1970) "The Working of the Regional Development Fund: a Problem in Decentralization in Rural Tanzania", (mimeo), paper to the Universities of East Africa Social Science Conference, Dar es Salaam.
- Ency, P.B., ed., (1969) Systems Thinking, Penguin Books, Harmondsworth.
- Garrett, John and S.D. Walker (1969) Management by Objectives in the Civil Service, CAS Occasional Paper No. 10, HMSO, London.
- Gertzel, Cherry (1970) "The Provincial Administration and Development in Kenya 1965-68", (mimeo), paper to the Universities of East Africa Social Science Conference.
- Meyer, Judith, Dunstan Ireri and Jon Morris (1971) Rural Development in Kenya, East African Publishing House, Nairobi.
- Holmquist, Frank (1970) "Implementing Rural Development Projects", in Goren Hyden, Robert Jackson and John Okumu, eds., Development Administration: the Kenyan Experience, Oxford University Press, Nairobi.
- Humble, John W. (1979) Improving Business Results, McGraw-Hill, New York.
- Kenya Government (1971) Report of the Commission of Enquiry (Public Service Structure and Remuneration Commission) 1970-71 (The Ndegwa Commission Report), Government Printer, Nairobi.
- Kenya Government (1972) 1972/73 Estimates of Recurrent Expenditure of the Government of Kenya, Government Printer, Nairobi and Development Estimates for the Year 1972/73, Government Printer, Nairobi.
- Kulp, Earl M. (1970) Rural Development Planning: Systems Analysis and Working Method, Praeger, New York.
- Kirunda, Charles R.A. (1971) "Problems of Implementing the Rural Development Programme in Ankole District, Uganda, during the 1969/70 Financial Year", (mimeo), Department of Political Science and Public Administration, Makerere University, Kampala.

McGregor, D. (1960) "Theory X and Theory Y" reprinted in D.S. Pugh, ed.,
Organization Theory, Penguin Books, Harmondsworth, 1971 from D.
McGregor, The Human Side of Enterprise, McGraw-Hill.

Moris, J.R. (1972) "Administrative Authority and the Problem of Effective
Agricultural Administration in East Africa", The African Review, Vol. 2,
No. 1, June.

Nellis, J.R. (1972) "The Administration of Rural Development in Kenya",
East Africa Journal, Vol. 9, No. 3, March.

Oyugi, W. Ouma (1971) "Local Participation in Rural Planning and
Administration", (mimeo), Institute for Development Studies, University
of Nairobi.

Reddin, W.J. (1971) Effective MBO, Management Publications Limited, London.

Waterston, Albert (1968)

FIGURE 1: THE RURAL PLAN MANAGEMENT SYSTEM

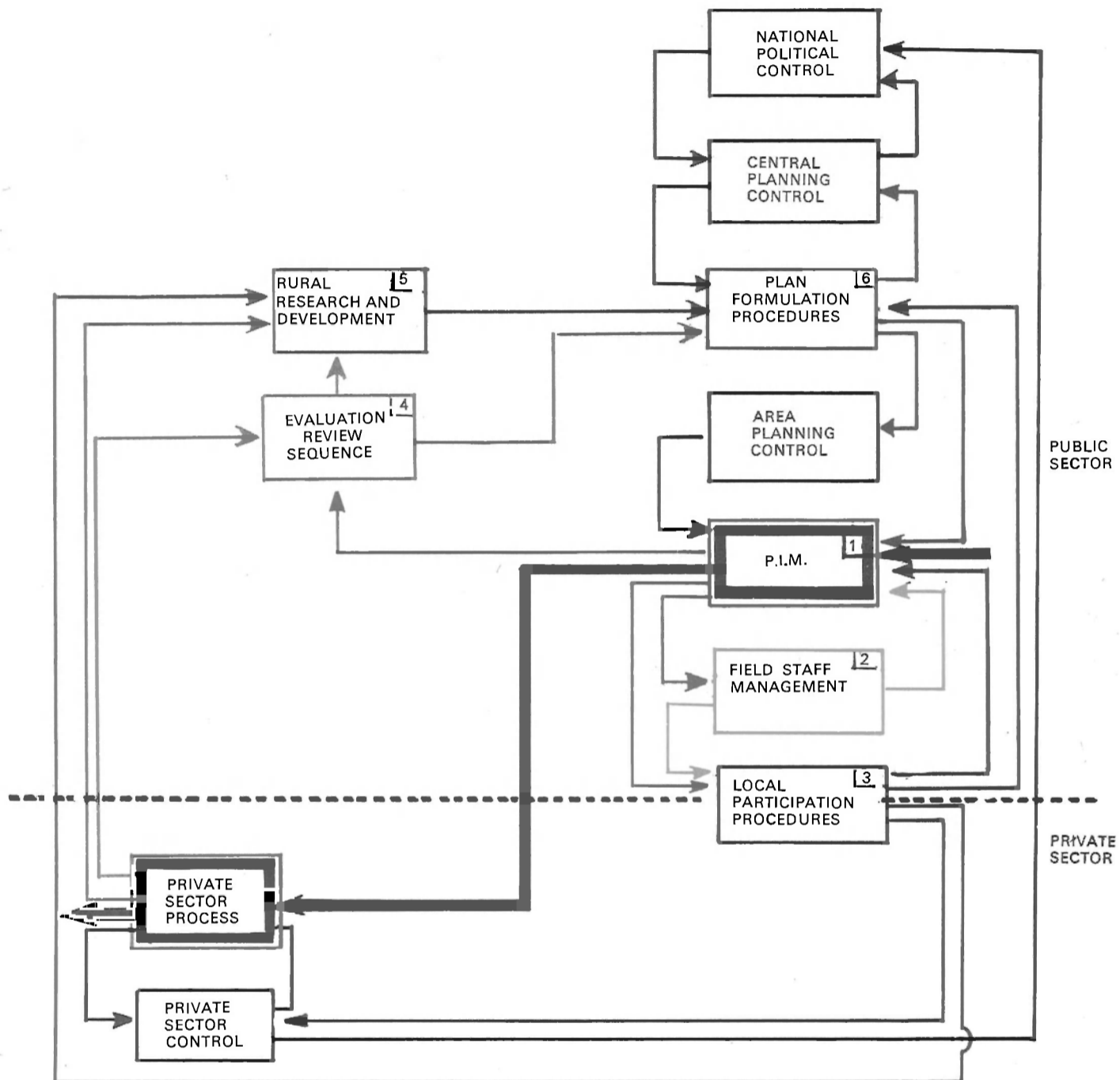

KEY: = RESOURCE FLOW

= PRODUCTION PROCESS

= PROGRAMMING AND IMPLEMENTATION MANAGEMENT (PIM)

= FIELD STAFF MANAGEMENT SYSTEM (FSM)

= LOCAL PARTICIPATION PROCEDURES (LPP)

= EVALUATION REVIEW SEQUENCE (ERS)

= RURAL RESEARCH AND DEVELOPMENT (RRD)

= PLAN FORMULATION PROCEDURES (PFP)

FIGURE 2: MANAGEMENT LOOPS AND PERIODICITIES IN THE RURAL PLAN MANAGEMENT SYSTEM

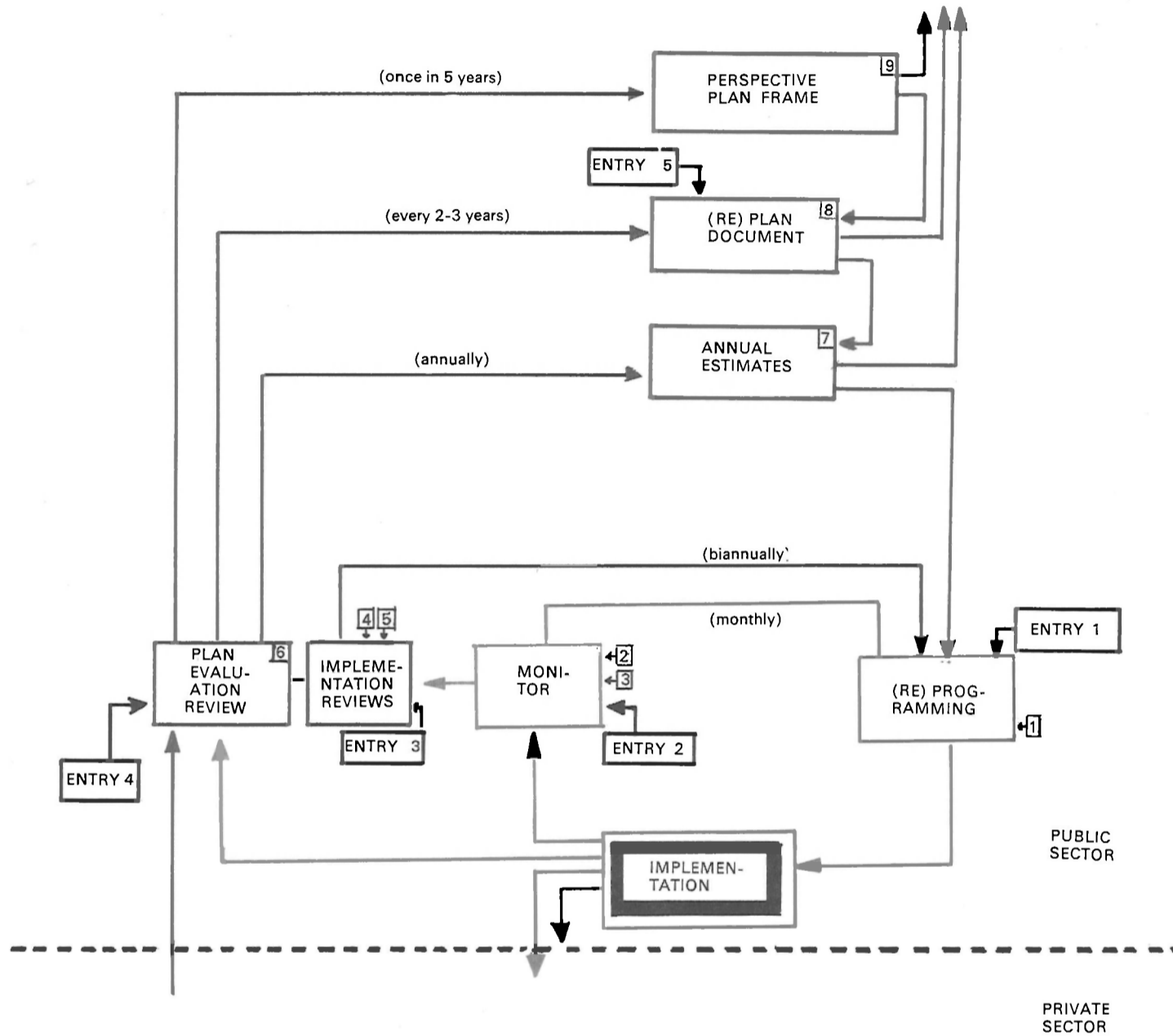













- KEY:**
-  Programming and Implementation Management System (PIM)
 -  Annual Programming Exercise (APE)
 -  Monthly Management Meeting (MMM)
 -  Monthly Management Report (MMR)
 -  Evaluation Review Sequence (ERS)
 -  Annual Implementation Review (AIR)
 -  Internal Implementation Review (IIR)
 -  Plan Evaluation Review (PER)
 -  Plan Formulation Procedure (PFP)
 -  Annual Estimates Exercise (AEE)
 -  (Re)plan (REP)
 -  Perspective Plan Frame (PPF)

FIGURE 3: A SEQUENCE FOR PROGRESSIVE REPLANNING WITH THE RURAL PLAN MANAGEMENT SYSTEM

