

EAST AFRICAN INSTITUTE OF SOCIAL RESEARCH
CONFERENCE PAPERS - JANUARY 1966

NOTE: The papers read or presented to the Conference are issued in five parts. They are grouped broadly by subjects, for convenience in referring to related papers, rather than by the specialisation of the author.

- PART A - Economics
- PART B - Political Science
- PART C - Sociology I
- PART D - Sociology II
- PART E - General Sessions

THIS IS PART C OF THE CONFERENCE PROCEEDINGS.

- 379 D. Boswell, U.C. Zambia - KINSHIP, FRIENDSHIP AND THE CONCEPT OF SOCIAL NETWORK.
- 377 H.P. Cart, Univ. of Rwanda - CONCEPTIONS OF POLITICAL RELATIONS IN THE KINGDOM OF BURUNDI.
- 366 J. Cornish-Bowden, Makerere - RE-OPENING OF THE CHILD STUDY CENTRE AT THE MAKERERE INSTITUTE OF EDUCATION
- 363 J. Gugler, Makerere - ON CONCEPT OF URBANIZATION
- 373 E.W. Hansen, Makerere - BRITISH ADMINISTRATION & RELIGIOUS LIBERTY 1890-1900
- 351 J.D. Heijnen, Nyegezi Soc. Res. Centre, Mwanza - SOME THEORETICAL PROBLEMS OF SURVEYS IN USUKUMA.
- 358 C. Hutton, Makerere - ASPECTS OF URBAN EMPLOYMENT IN UGANDA
- 397 H.P. Junod, ex S.A. Penal Reform Society - RESTITUTION AND AFRICAN PENAL CONCEPTION
- 359 J. Kesby, EAISR Associate - Rangi - THE WARANGI MUSLIM TRADITIONALISTS, CATHOLIC PROGRESSIVES.
- 365 A. Molnos, EAISR Associate - METHODOLOGY OF AN ATTITUDE TEST.

Subscribers receive 5 envelopes, containing Parts A; B; C; D and E respectively.

Write to the Administrative Secretary, EAISR for further copies. Single papers Shs. 2/- or its equivalent, Part A, B, C, D & E Shs. 15/- each.

KINSHIP, FRIENDSHIP AND THE CONCEPT OF THE SOCIAL NETWORK

By

D. M. Boswell

An early version of this paper was discussed in Professor J. Clyde Mitchell's seminar in the University College, Salisbury in 1964, and this revised version owes much to that discussion. It represents the first of a series of three related analyses of the social network of a particular "middle class" man in 1964, a comparison with his wife's network, and the ways in which his network altered over a period of two years in a situation of personal and national change. It is concerned almost exclusively with interpersonal relations as exemplified by this 23 year old Zezuru, and the relevance of these to the concept of the social network and the ways in which this concept may be used in exploring the content of urban kinship and friendly relationships.

The concept of a social network as a set of formally unstructured interpersonal relations was introduced into a non-psychological study of human relations by J.A. Barnes in *Class and Committees in a Norwegian Parish* (Human Relations Vol. VII, No. 1, 1954) and used as method of analysing the ways in which the fishing vessels recruited their crews in a social field that was distinct from those of local government and industrial organization and could not be classified as:

"A corporate body, but rather a system of social relations through which individuals carry on certain activities which are only indirectly coordinated with one another."

Elizabeth Bott, in *Family and Social Network* (Tavistock 1957) carried the use of the concept into the study of conjugal relations and deduced from the results that social status and the type of inter-relationship of the conjugal networks were correlated. This typology of loose and close-knit networks has been used by both Philip Mayer (O.U.P. 1961)¹ and E.A. Pauw (O.U.P. 1963)² in their East London studies but elaborated only to include the comparison of social ties and cultural habit with network patterns and institutions. The concept has been taken out of the set of ego-centred case studies of Bott and A.L. Epstein (*Human Problems in British Central Africa* XXIX June 1961) and related to social relations in general.

Epstein in *The Network and Social Organization* provides a series of pointers to the nature of the concept but only follows out some of the paths. As these are all essential to the use of the concept it is the concern of this paper to try and carry this still further.

1 Townsman or Tribesman. 2. The Second Generation.

"Each individual African is involved in a network of social ties which ramify throughout the urban community and extend to other towns and to the tribal areas." (Epstein, p. 31).

The neighbourhood, kinship, tribe, status similarity and common associational membership may all be important means of selection to the personal network which is essentially ego-centred and composed of approximate social equals. Epstein suggests a typology which should be related to 1) the interconnectedness of the members of an individual's network and its tight or looseness. 2) The range of intensity involved in each relationship with (a) Kin, and (b) Status equals. 3) The effective as opposed to the extended network, where the members are of equal status and almost become a clique. The extended ties, he suggests, may be an important means by which norms are transmitted down the social scale. Here I think he ignores the fact that extended ties are flung out in both directions - up and down, and may be important means of reinforcing low status and 'traditional' norms. The principle remains relevant.

In this paper I shall be primarily concerned with the nature or content of network relationships, the ways in which individuals are selected into it, the modes of interconnectedness in loose and tight knit networks and the ways in which these may be affected by particular situations, e.g. the dynamics of this form of relationship which may change over time and between places with resulting changes in the content of individual relationships. Here I am concerned with those ties that exist outside the circumscriptions of work or other group relationships, leisure-time contacts where there is a relatively large element of choice possible.

The set of interpersonal relationships that has been taken for this case study is one that I have observed as existing and developing over a three month period in 1964 and again in December 1964 and December 1965. Ego is a Zezuru, aged 23, who was born in Southern Rhodesia but went with his family to Lusaka in 1953 where he went to primary school and later 2 years of secondary school in Munali in 1958. He left school as he did not pass out well enough and this has probably contributed to his driving social and educational ambition, his explanation being that his father reckoned that he had had sufficient education. He trained as a social worker in a three months course after which he was appointed to the post of social welfare worker in Livingstone where he was a leading member of the smart and sober educated set for two years. By this time his best friend and colleague had left to study Law in London and he had himself been awarded a private scholarship to study at an American college. However for various reasons this fell through at the last minute and although he had his O levels he did not wish or failed to gain entry into the two relevant higher educational institutions in the Federation. He declined to go back to his old job,

partly due to fear of being sent to one of them, to the embarrassment involved, to a desire to escape from previous involvement of his professional and private life, and also from the strained relationships that existed in the political constituency of which he had been an official due to 'Bemba imperialism' expressed against foreigners. He spent about six months reorganising his father's store, putting it back on a viable debt-free and pilfer-proof footing, and then applied for a semi-clerical post which utilised his social work experience but was outside government, with the intention of working for his A levels and further University entrance, within the Commonwealth.

The three months taken for this case study were the first three months spent back in Lusaka since he left school. Ego was living in one of the houses of the new fully-serviced housing estate built by the municipality which became the home of Lusaka's elite until Zambianization began in the Civil service and town houses became available for government servants in the administrative and executive grades. It should be noted that the network considered here is an abstraction in that I have not included his wife's friends and relatives or their joint network. Mention must however be made of the fact that Ego was then engaged to a Bemba school teacher who resigned her post in Livingstone to come to Lusaka to study Domestic Science at the College of Further Education. It would not be an exaggeration to say that Livingstone is the most important marriage market for the educated elite in the southern half of the country as it contains a Protestant teacher-training college, a Roman-Catholic secondary school for girls and an elementary nursing school at the hospital. Because of this it acts as a draw to many men from outside and has resulted in many of Ego's male contacts involving female ones as well. (See diagram 6: Education and Religion of wives and fiancées.) The preference of the elite for girls who have attained some measure of secondary education and professional training necessarily narrows the field of choice because of the scanty provision for women's education.

Here follows a brief summary of those I have shown in Ego's network. In the seven attached diagrams it will be seen that each of the members is indicated by a letter and this is in the same position in each case. From them it will be clear that the ordering is related to certain predominant common characteristics between adjacent members but this is purely for diagrammatic convenience. (See diagram 8 A.)

A - Father of Ego, who left home many years ago to school himself and became a teacher, a policeman and then came up to Zambia to set up a store, run a taxi business in Lusaka in 1953, and then settled as a peasant farmer to the west of the city where he has a store and runs grain to Barotseland, His wife is a

school teacher at the local mission school. A recently re-established contact with his elder brother in Rhodesia,

- B. who is the headman of their village. He came up with his family for Christmas and stayed for four months. He has land for A in his village and stated that the spirit of the latter's name-sake ancestor had come out in him as he was a good farmer.
- C. Younger son of B used to work for A but absconded with a lot of money. He came back with his father and is unemployed. However A took him back as a driver on conditions laid down after consultation with Ego that he is an employed labourer only without the privileges of a kinsman.
- D. is a son of B's younger brother who died in an accident. A driver for a Rhodesian commercial traveller, he shows up at frequent irregular intervals and beds down with Ego. Unmarried, he has two children who are looked after by his mother in village, although he laughs at old and country people. Ego calls him a 'ticket'. Whenever he comes to stay he takes a tie or something of his and even rummaged through his personal letter file.
- E. D's younger brother is close to go and they correspond. At one time Ego was persuading him to come up to Lusaka but this changed after Independence. He is a photographic assistant and is married with one child. Ego feels that his family interfere too much in his married life. They belong to opposing Parties in S. Rhodesia.
- F. A Rhodesian on a social work training course at the college Ego refused to go to. He lives with his family in the same street. His wife is an S.R.N. who claims kinship with Ego. This she pressed when his fiancée arrived and in a half-jocular way took it upon herself to show her the customs of her future affines, dutiful behaviour etc. Ego refuted this claim to start with but accepted it when they persisted and now calls them his "relatives".
- G. Lives just behind Ego. He is the representative in Zambia of the same political party as Ego and tried to get him to take office. He has since left for another country.
- H. A mineral waters salesman, whom Ego met in the course of work, but who lives just behind his house, he regularly sends his younger brother to ask for car-lifts or for money, £5 a time. Ego has a car and therefore is assumed to be rich but seldom responds to the demands. H absconded with the business funds.

- I. One of Ego's greatest friends, he was at senior, primary & secondary school with him although he went on to Form 6 and is about to go to University. He visits more than three times a week. His girl friend taught at the same school as Ego's fiancée. He stays with a young uncle in the same suburb.
- J. An ex-school friend back from Moscow after failing his course at a rather inferior university. He has a girl friend living some 50 miles outside Lusaka, by whom he has a child but whom he refuses to marry because she is socially and educationally beneath him. Ego disapproves of his behaviour, his drinking and his requests for lifts and avoids him where possible.
- K. A school fellow of Ego who was also his colleague in Livingstone and left to study Law in London at the same time as Ego was due to leave for America. They write to each other every few months. With V they were the leaders of the smart sober set in Livingstone.
- L. A school fellow of Ego, who went to Salisbury University and used to spend his holidays with K in Livingstone. He fell for a rather snooty girl in the Information offices who has since married T. Ego says that if he is in trouble he always comes to him and stayed with him for a month without buying anything before he got a good job in the mines and left for the Copperbelt, after which he has never communicated with Ego again. In Livingstone he is reputed to have vacillated between the drinking and the sober sets and denounced each to the other during the process of transferring.
- M. A school fellow, who worked in the government offices in Livingstone, and is now training to become a secondary school teacher although he wants to go overseas to train as an adult education organiser. He visits Ego whenever he is in town and is very close to him.
- N. (See Diagram 8 E) Mother of O and P, who is herself divorced from their father and comes to stay with her sons regularly wherever they are living. She met Ego in Livingstone where her daughters in law were at the same school as his fiancée. She comes to discuss her son's domestic disputes with Ego, knowing him to be a welfare worker.
- O. Elder son of N and of a Lozi Induna, who met Ego in Livingstone when unemployed, he has since been one of the first Africans to train in Bulawayo as a R. Railways fireman. Due to racial tension he left the railways and for several months was virtually unemployed in the hope of being articled to an accountant. So far there is no child and there are frequent rows with his wife which

results in both looking to Ego and his fiancée as friends outside the family to whom they can talk. His wife took over the job that S vacated. They live in the same street.

- P. Younger brother of O, who also goes to classes at the Further Education College, he works at the Labour Office. He was able to recommend a job to his brother. He has the reputation of being the master of his own house with a dutiful wife. They live in the same suburb. Unlike O and Q he has a wide range of Lusaka, non-Lozi friends.
- Q. Half-brother of O and P, who was in the Government offices in Livingstone, and later came to Lusaka to take a job in Broadcasting. He stood as a candidate for V's party in opposition to the now-ruling party at the time of an anti-Lozi demonstration in U.N.I.P. Ego disapproved of his high expenditure on material status-goods which is beyond his income.
- R. A well-connected Lozi who is an uninhibited extrovert constantly involved in clashes with authority, he used Ego, in Livingstone, in his professional capacity both when he was in prison and in his matrimonial entanglements with the some of the most influential families in Barotseland and the ruling political party. When he seemed to be continuing this relationship with Ego in Lusaka, the latter helped in the first instance and then made it clear that he would do so no more.
- S. An ex-school fellow, whom he knew in Livingstone and had to help with his matrimonial problems in a professional capacity there, he was a party official there until he fell foul of the same tribalism as Ego. He has twice he helped O get jobs that he has vacated in order to take up better ones. Politically disappointed he has been able to get on himself though resentful of the lack of recognition his services received. Ego avoids him in order to extricate himself from S's domestic disputes which have involved him in some embarrassing neighbourhood incidents.
- T. School fellow, who went on to Form 6 and Salisbury University, and on leaving took a leading post in the Zambian Students' Union. He had been on the same social work course as Ego. Contact had lapsed until Ego's working contacts led to the re-establishment of the relationship, which he regarded as friendship but was a means to the attainment of a university scholarship, which fell through.
- U. A well-to-do Malawian who had left that country for political reasons and was working as a representative for a firm and moved to the same suburb as Ego after being accepted for an American course. Ego established his contact through his work and was able to arrange to take over U's house when he left.

- V. A graduate from Fort Hare and a Tonga who was the leader of Ego's set in Livingstone and Chairman of the club, he was the editor of a local government newspaper which he had to leave after his involvement in the breakaway political party from the A.N.C. in 1963. His party failed even to survive the elections and for a time he tried to reform A.N.C. from inside until he was expelled with his colleagues.
- W. A political friend of Ego in U.N.I.P. He had been a Regional Secretary in Southern Province until, after self-government, he was sent on a diplomatic training course. When in Lusaka he visited regularly for meals and to borrow blankets and discuss his plans for marriage and the social education of women. Due to the fact of
- X. his close contact with one of the government ministers Ego hoped to establish contact through him and alleviate the troubles his father was experiencing in an A.N.C. area due to the association of Rhodesians with the government party. Police were sent out but nothing was achieved.
- Y. A leading official of the A.N.C. with whom Ego established contact through his work. After the failure of the Police raid Ego hoped to make a deal with him to provide transport to his father's area for him to make a political speech on condition that he included some protective clause in the interests of his father's position in the locality.
- Z. A school fellow who lived nearby and came from the same Mission that Ego's father's wife taught at, he worked in the Bursaries office of the Ministry of Education and was able to help Ego with his applications and those of his wife and keep them informed of developments. Ego helped him with lifts home.
- J School fellow and fellow social work course member, he was at the college that Ego refused to go to. He got into trouble at the college and talked it over with his friend, Ego.
- B A senior social welfare worker with aspirations similar to Ego who worked in the local welfare office until he left to join the Broadcasting station. He was very friendly with Ego and visited frequently, complaining about the lack of prospects in his welfare job, similar to that which Ego had left.
- S A graduate from Salisbury University, he was an Administrative officer in the Ministry of Education. He had been at school with Ego who claimed friendship with him, which was not reciprocated. It did, however, enable Ego to further his wife's application for a scholarship and get permission to resign without a long period of notice.

5. An ex-primary school-fellow who had gone on to the technical college and during the holidays would do repairing jobs cheaply in order to get experience. He repaired both Ego's car and A's lorries which frequently collapsed after the trip to Mongu.

The seven diagrams indicate the intensity of Ego's relationship with each member and the means by which they were selected into his network. Only a brief verbal summary will be attempted here as the interlocking characteristics are best seen by the comparison of them.

Diagram 1

The strong emotional bonds between kinsmen and the economic interdependence involved in such intense relationships is shown in the same way as the intense bonds of friendship, with his long-term school-fellow, I, and two school fellows who left early as did Ego and had worked near him in Livingstone and Lusaka, and O, whose domestic troubles in the same street closely involved himself and his wife. This represents my estimation of the intensity of the relationship and is partly based on frequency of contact three-six times a week, whilst that with his friends is one-three times a week. Using other criteria however some of the relationships with these could be considered more intense. Finally there are those who, because their relationship is specific or infrequent are classed as acquaintances. Their number could no doubt be considerably increased and represents the important part of an open system. It is tempting to try and abolish this indefinable amalgam by transforming it into economic terms as in Diagram 7, but by doing so one ignores the emotional factors involved in such relationships which sustain a contact through its dormant periods, as in the case of the absentee, K. I have taken this network at a particular point in time, in fact in a particular situation, which differed in Livingstone and again a year later. The position of most of the members is not fixed and there is considerable movement in and out of the active and passive, or as my colleague Bruce Kapferer has called them, the kinetic and latent zones of the network.

Diagrams 2 - 7

The rest of the diagrams indicate particular strands in the relationship of Ego with each of the members and their relationship with each other on the same grounds. The lines indicate not only the intensity of each relationship but also the direction in which it is operative (see diagrams 1 and 7). Kinship, Tribal membership, common status through education, or identical occupation, or past membership of the Livingstone elite, common or different political ties and female entanglements, and lastly economic and other instrumental connections are indicated, and should be viewed as a total of multiplex strands.

Though there are other characteristics that could demonstrate their commonness as well these are so general as not to be very significant; most of the members of the inner rings are of the same age and involved in related pre and post marital crises, and are living in Lusaka and attending classes at the College of Further Education to improve their secondary and professional qualifications. Also I have not attempted to indicate the ties of friendship between network members as this would be misleading as those parts of their networks which are not common to Ego would not be indicated. Apart from Politics and Religion, which is practised by few of the men, unlike their wives, I do not know their associational membership. Social norms differ strongly between those who do not drink and those who do so publicly. This was particularly the case with the Livingstone elite with the result that this perpetuated in Lusaka in the early months of Ego's stay there, although certain individuals, e.g. R, felt their Livingstone associations sufficient to overcome the barrier that had existed there, a feeling unreciprocated by Ego who stood to lose the freedom from the professional/private confusion of his life. By taking these strands together and separately we can see that these people are bound to Ego by a series of multiplex or single strand relationships which create for him a loosely-knit network. However, by the superimposition of the various strands of this we can detect a series of interlocking closed and open networks which go to make up the total.

13 of those represented were at school at Munali, 10 of them at the same time as Ego, and a further one at Primary school with him. This makes it virtually unnecessary to rank the members according to social status and occupational prestige as it follows from their education. Diagram 9A is an attempt to demonstrate this point by reference to relative income and power. The close relationship between education and occupational status is further demonstrated by their coincidence with residential placement. 16 of the network members were living in the new middle-income suburb where most residents were, in March 1964, earning between £20 - 40 a month. These three characteristics cut across tribe and the intensity of the relationship and are the links between Ego, a Zezuru from Rhodesia, and the Zambian elite. If kin and fellow Rhodesians are excluded education provides the universe from which most of Ego's friends are drawn. It should be emphasised, however, that this does not imply that 'old boys' of Munali band together for there were many others at school with Ego who are not included. It emphasises the general validity of the point made by Barnes and Epstein that network members are generally of similar social status. Because there was only one such school, however, potential bonds exist which may be made instrumental. In the case of P, U, and T Ego was able to manipulate the school link in order to get his fiancée into College and himself onto the scholarship list again. From the point of

view of P and T the contact has been one of helping Ego rather than that of fulfilling a duty to a former school-fellow, which seems to be the way he sees the relationship. Because this Munali universe has such status and occupational implications it is most important to know who got into the school in the recent past before the expansion of secondary education. It is obvious that because of the boarding fees the sons of those with a higher income than most will have been favoured as well as the sons of those with a higher education. Ego's father was a taxi driver, driving instructor and storekeeper as well as being a self-educated ex-teacher. Sons and nephews of religious ministers, teachers, chiefs whose headquarters are near a mission, and Lozi indunas and princes are all placed in a favourable position but more than that I cannot say. Those at the top of the traditional or modern social scale have had various advantages. It is also significant that 3 of Ego's most intimate friends should have left school early like himself, though in different years.

Secondly it emerges that, apart from the 4 who had had the same occupation as himself, there are 11 who belonged to the same set in Livingstone 6 of whom had been at Munali as well. All were in the better clerical jobs in government except two. O was unemployed and came to ask Ego to help him find a job but then joined the Railways. V was the editor of the Tonga-language newspaper and had a superior job. As already mentioned, being ex-Munali students had resulted in them having jobs of the same status, which further resulted in them being allocated housing of the same type. As they were few in number they were brought together as a peer group. The large Lozi element in Ego's network is the result of this stay in Livingstone, particularly as so many of them were involved with Ego in his professional capacity there. 3 of them have tried to perpetuate this relationship in Lusaka in getting help in their marital and domestic scapes but Ego has been most unwilling to be so involved again. One of his reasons for not wanting to go back to Livingstone was the desire to avoid such an exhausting personal involvement as his work and the tightly-knit network of the elite had brought him there. As in Lusaka, but more clearly in Livingstone where their numbers were smaller and the choice of acquaintances more limited, this elite of young bachelors were divided according to their style of life, between the heavy public drinkers and the sober and Ego comments critically on L who shifted between the two sets. This peer group operated almost as a formal group and Ego and V founded a club for high-status young bachelors and married men, which was intended to provide a social centre for both and a place for married men to 'bring out' their wives. However it had to be disbanded because of trouble caused by the wives whose husbands also brought along sophisticated and well-educated girls from the same hospital and schools at the bachelor members. The bulk of the financial cost and loss was borne by Ego and V.

Lastly Livingstone provided the situation for political contacts and those that have endured in Lusaka are a direct result of his activities there where he was a constituency trustee and of use to the ruling party in the 1962 election as a campaigner for the European vote. With the new constitution, I suggest, and increasing Bemba pressure which resulted in the election of a new regional secretary, whom both Ego and S, the "obvious choice", rejected, Ego's political value was over. Since coming to Lusaka he has been involved increasingly in solely Southern Rhodesian politics and just retained friendly contact with his U.M.I.P. ex-colleagues. However he was able to manipulate one of these to establish contact with a Minister and others to send in Police to defend his father from A.F.C.

It is only in this case of political manipulation and in the single case of a primary-school fellow being employed to repair his father's lorry that there is any connection between Ego's friends and his kinsmen. As all the rest of his father's family are anyway resident in Southern Rhodesia there is little chance of any being so involved anyway. But those that have come to stay have only in one case been invited to do so as a friend, E. & D is called a 'ticket' C is now working for Ego's father according to an agreement laid down by the two of them. The relationship between father and son is very intense. Not only does the father direct the son but he comes to him for advice and, I think, sees in him the culmination of his own ambitions. A is a self-made man who had to break away from his kinsmen to get on at all but in recent years has been moving closer towards them again. Ego regards most of them as worthless countrymen who are now eager to sponge on his father and himself because of their success whilst they had no interest in them before. However B has kept a piece of land for A to return to in the village. The potential reciprocity of this relationship has, I suggest, become particularly important to A since things took a downward turn for Rhodesians in Zambia, and the seeming inability of the Police to do anything to quieten the local A.F.C. dissidents.

It does not necessarily follow that kinship links should be divorced from those of friendship as is shown in the case of the Lozi cluster, N, O, P, Q, where N keeps house for O during the crises in his marriage and P is able to offer him jobs. Q is staying with his half-brother O despite the fact that his political contacts with V and his P.D.C. colleagues are embarrassing. All three brothers went to secondary school in different places but have high status jobs and many friends in common who came to visit P when he was sick and O, whether his wife was at home or away.

Epstein points out that even kinship may depend on a situation to turn it into an instrumental relationship. Kin of all sorts may be recognised and important in the urban situation who would be barely known in that of the village. This is obvious in the case of F, who is studying social work and whose wife is living in the same street as Ego. He met her in the course of his work in Lusaka and at the time she declared that from his name he must be related to her. Ego told me that this could only be so remote as to mean nothing and did nothing more. However, she persisted and her husband complained that Ego never went to see him at the college. Ego remarked that F never came to visit him either. After the arrival of his fiancée F's wife rebuked Ego for not bringing his wife to visit her "sister-in-law" and she was invited to tea, after which Ego's fiancée was taken on a long visit to her house where she was shown the kitchen and in a jocular way told what her duties were and how after marriage she would be subservient to her husband's kinswoman. All this Ego and his fiancée took rather awkwardly as Ego theoretically believes in the notion of partnership in marriage but since that event he has called this couple "my relatives". To the visiting couple who know few people in Lusaka this relationship has a considerable emotional and social importance. To Ego, who has several relatives living close to the town with whom he maintains an intense relationship, it has become socially convenient in order not to get a bad name and, I suggest, because there is no other obligation involved in the relationship. F even has a car which his wife uses to get to work in and has his wife's mother staying to look after the children. Ego enjoys children and these are the objects of his attention and get sweets from him. In the urban situation a remote putative kinship link has become an established relationship, at least until the situation changes.

If we are to understand the nature of the relationships, we must consider their content in relation to the concept of reciprocity. For any relationship to exist at all there must, of course, be some element of reciprocity but here I am concerned with the specific involvement of interest and advantage (see Diagram 7). From the case data it is clear that reciprocity may involve the interchange of different things, e.g. Ego gives W meals and lends him blankets and is introduced to the Minister and put onto the right people who can help his father. Where small demands are made, as by F, there is no problem, but where there are regular demands for money and expensive lifts, as by H and J, the continuity of these relationships is threatened as Ego consciously resents these demands by people whom he says mistake his thrift and consideration for others for affluence and personal weakness.

Secondly there has been a change in Ego's network and the content of his relationship with some of its members over time. The fact that they were great social friends in Livingstone has kept Ego and V together as friends but

the political activities of the latter are opposed to the allegiances of the former and the fact that the elite in Lusaka is so much more numerous has made a more loosely-knit network possible. There are 750 families in the Lusaka suburb. S is no longer a political colleague as both have been passed over in the new developments of the party. At the same time his marital problems are no longer the professional concern of Ego, who is trying to rid himself of such entanglements, and gave the minimum of assistance. S, however, expresses disappointment that Ego does not visit him. R. has similarly been discarded although in his time he has involved Ego in a series of crises over his drunken car-crashes, his misappropriation of government funds, his divorce from one Lozi princess and his elopement with another. The occupational status and integrity of Ego no longer obliges him to get involved involuntarily. Others have entered the extended network though in certain situations they have a highly effective relationship with Ego, U in helping his father and Y, whose house he wanted to take over when he married. Both contacts have been established through another persons and both are reciprocated. Herein lie the dynamics of the network which is similar to the regrouping of the fishing crews described by Barnes as a seasonal occurrence.

From the ways in which these spheres of interaction are interrelated and may involve different people a problem arises in the use of the terms "tight" and "loosely" knit networks. If we exclude kinship and its tribal quasi-form, there is no problem in determining the methods of selecting network members or the bounds of the possible network which is derived from common education, social status and residence. However if we relate such a "total" network as Ego's to the community at large, rather than to the rest of those of similar social status, it represents a form of tightly knit network. Simultaneously the links binding N, O, P, Q, and even S together, reinforced by O's marital and employment problems represent a minute tightly linked network to which in these matters all others are of peripheral importance. Many others are however the beneficiaries of the same characteristic of P, his employment in the Labour office, but none with same multiplexity of ties with him as O. Like the terms effective and extended they must be related to the situation pertaining at the time.

One of Epstein's chief conclusions is that all those in an individual's effective network will be of a very similar social status and he suggests that an important way in which norms may change may be through a "percolation downwards" (Epstein 1961 p. 59) through the extended network. Leaving aside this notion of percolation, it will be clear from the rather crude representation of a social scale in Diagram 9 A. that this is certainly true of this network but that it reaches upwards as well as downwards. The diagram is based on a combination of an assessment of the jobs and incomes of the members and Ego's occasional

remarks about his attitudes to his kinsmen. The important thing to note is that all his intense and most of his friendly relationships are with those of very similar status and he would probably include still more as his equals who, like the graduates, would consider themselves superior. It should also be emphasised that though the relationship is less intense and less frequently activated the extended network may be used as a much more important instrument in a crisis than the effective ties which may be less competent or influential. This need not imply an enduring client/patron relationship. In this paper I do not want to dwell on Diagram 9 B which belongs to another paper and shows what happened to the social status of the members of Ego's March 1964 network by end of 1965, by which time he had established a totally different network of fellow Rhodesians who worked for the same party of which he had now become an official and were working in similar jobs in the industrial site. Due to her continuing education at the college his wife's network remained much as before though Ego tried to reduce the influence of non-Rhodesians to acclimatise her to his patrilineal customs, especially after the birth of their child.

All this raises the final issue as to how the network, once accepted as a concept, may be best investigated and used a means of discovering what is its type for different people. I have been particularly concerned with the use of the concept as a means of analysing observations of those who have been called in to assist in the solution of personal and familial crises, and how the non-institutionalized deal with marital disputes, childbirth, death, the organization of marriage, shortage of cash, housing or employment and the problems of sickness and old age in town. In a social survey of urban areas in Lusaka I included a question that listed a series of hypothetical crises and asked husbands and wives separately to whom they would go in the event of each happening, taking recent past experience into account. So far I have not taken out the result for each potential crises separately but the cumulative totals for each suburb is illuminating, giving the incidence of recourse to each category of person or institution. It is directly relevant to the concept of the effective and instrumental networks. In Kabwata, the low income suburb where wages ranged between £5 - £15 a month, no other institution was conspicuously mentioned apart from the hospital and the clinic. Among the men their own relatives were of primary and their neighbours of secondary importance, followed by an almost equal number of friends, fellow tribesmen and their wives' relatives. For their wives, however, their own relatives and neighbours were of almost equal primary importance, their husband's relatives of a high secondary importance and friends and tribesmen a low medium. This bears out the contention that the low-income wife is tied to her kin and close neighbours, which has been established by Bruce Kapferer's survey of networks in Broken Hill. Although some data I have suggested the contrary, more

prominent mention was made by the middle-income residents of the New Kamwala of recourse to the Welfare office, and other agencies such as the Labour office and the Police. As in Kabwata husbands and wives mentioned their own relatives as primary and those of their spouse as secondary but the difference on the part of men seems less marked. Tribesmen as a specific category are relatively unimportant and friends and neighbours of approximately equal importance for men and women. This data is important in demonstrating the primacy of personal contacts and actual kinship over institutional aid at all income levels in town, at any rate where such a choice was presented.

The latter is a crude form of question which presupposes that certain crises exist for every family at least potentially. However equally crude is the question which merely asks who are a man's friends or the people of importance to him as it leaves it to the man to set his own criteria for inclusion which are not only unknown but cannot be related to a common scale. Hence Epstein found that affines were mentioned but not agnatic kin presumably, he suggests, because to his informants it was obvious that they held primacy of place.

In this paper I have attempted to show the importance, both for clarification of the concept and its use in my own research of the content of the ties implied in the use of the term "network" of social relations, and of some of the other problems that arise in determining the level and scale of analysis and hence the use of relative terms such as loose and tightly knit, effective and extended. Only suggestive material can be gained in an intensive way, the implications of which can only be validated by reference to the general situation, e.g. the position of a Zezuru, who speaks seven languages and has lived in at least four different places for relatively long periods in his 23 years is a very special case, as he is in the position of being a potential isolate and also a man with a far greater range of choice of friends open to him. Barnes, Bott and Epstein have formulated the concept and demonstrated its usefulness in the analysis of personal relationships, and Mayer and Pauw have used it to illustrate certain characteristics of a larger urban society. From a research point of view there are two dimensions to the social network: firstly its structural nature - the frequency of contact between its members, and the reciprocity involved in interpersonal relationships which may differ in kind: secondly the instrumental aspect of the relationships and their content and the degree of emotional involvement. Both may be combined in particular analyses in a crude scale of intensity placing Ego in the middle of a series of concentric circles, those in the centre forming a quasi-clique of best friends.

DMB/ak

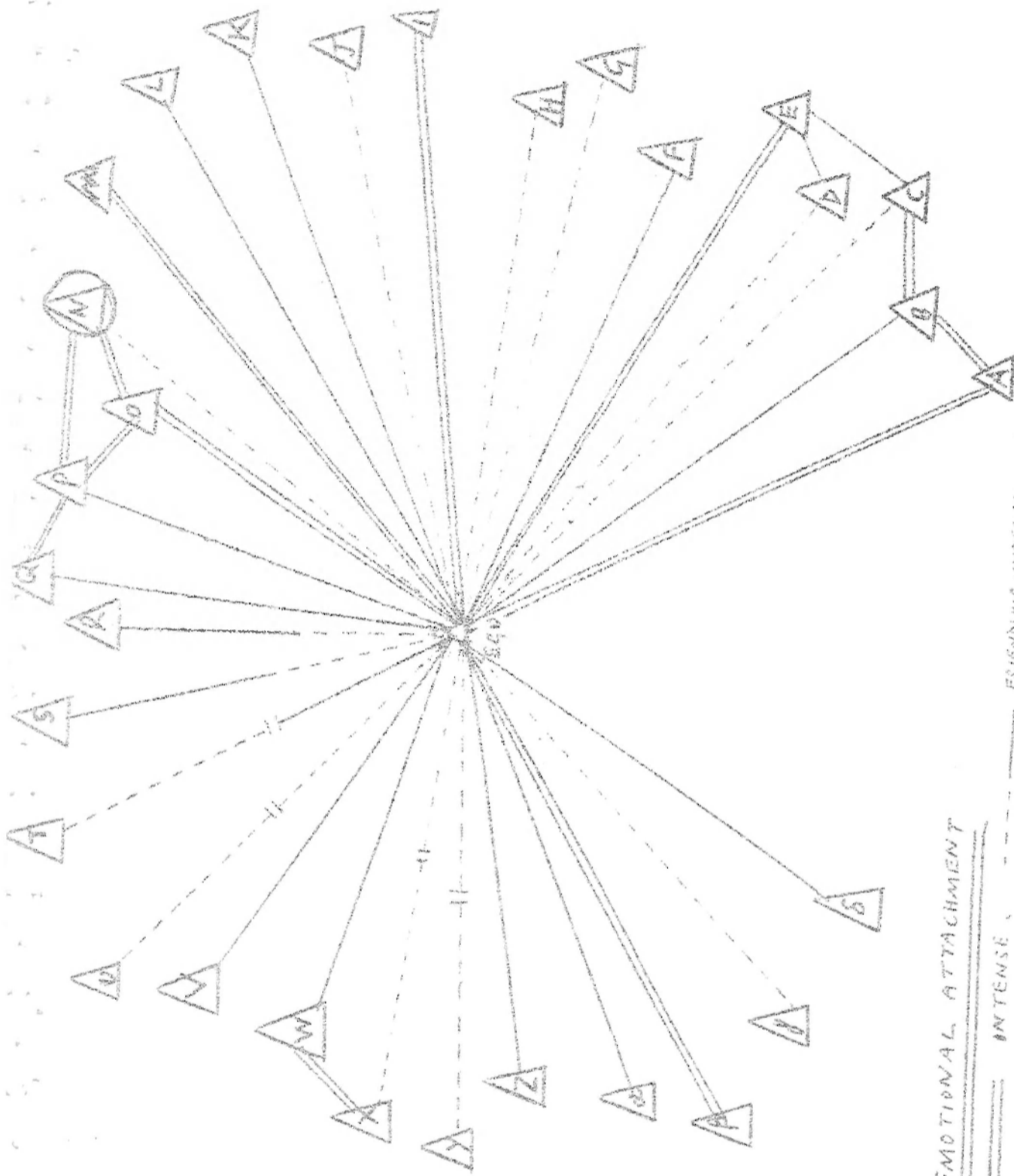

① EMOTIONAL ATTACHMENT

INTENSE, ——— FRIENDSHIP UNRECIPROCATED.
 FRIENDSHIP, ——— RELATIONSHIP ESTABLISHED
 THROUGH MULTIPLE MEANS.
 ACQUAINTANCE, - - - INTERLINKING INDICATES KINSHIP.

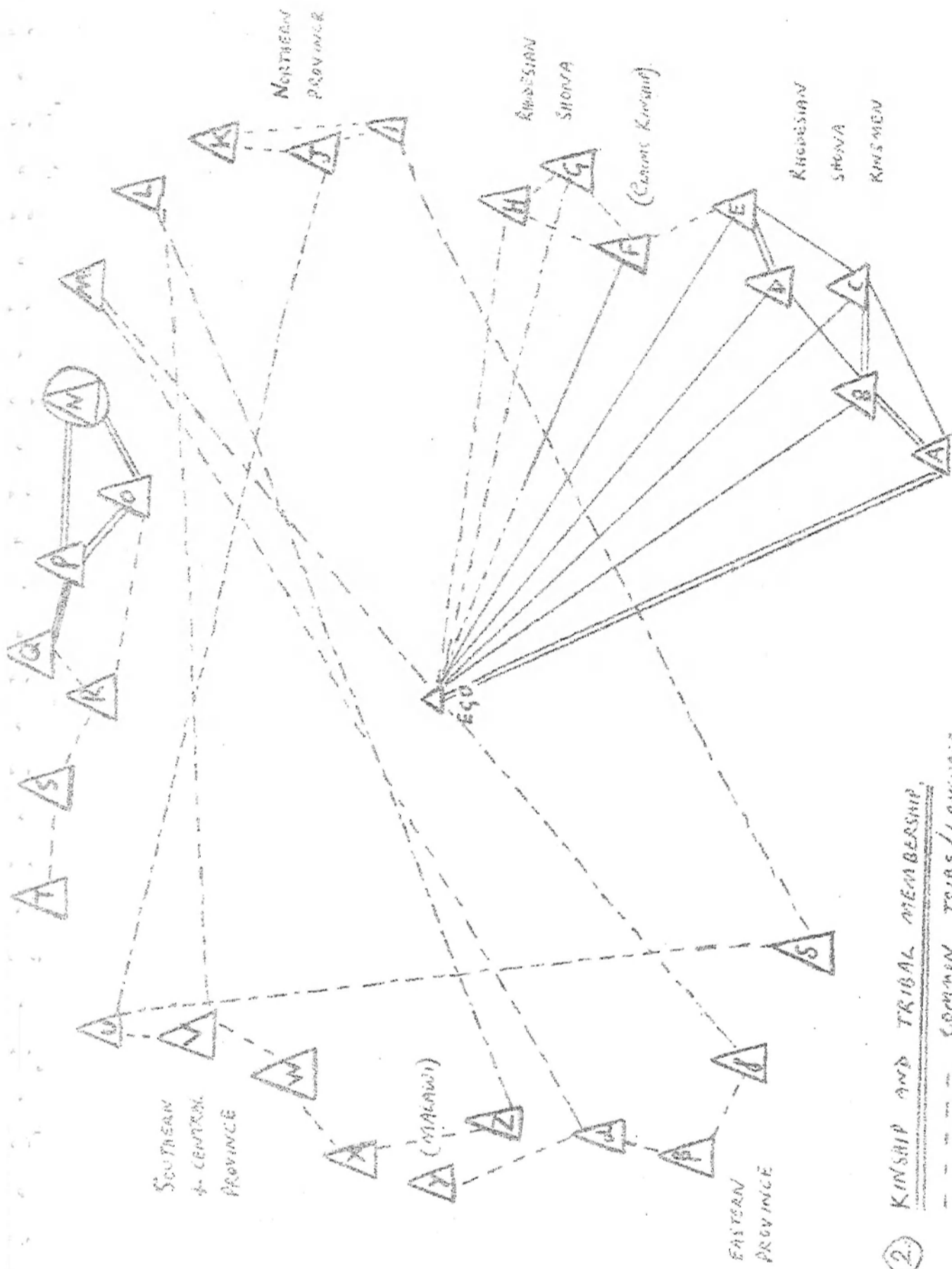

② KINSHIP AND TRIBAL MEMBERSHIP.
 - - - - COMMON TRIBE/LANGUAGE.
 _____ KINSHIP.
 = = = = KINSHIP (FATHER, SON, BROTHER).

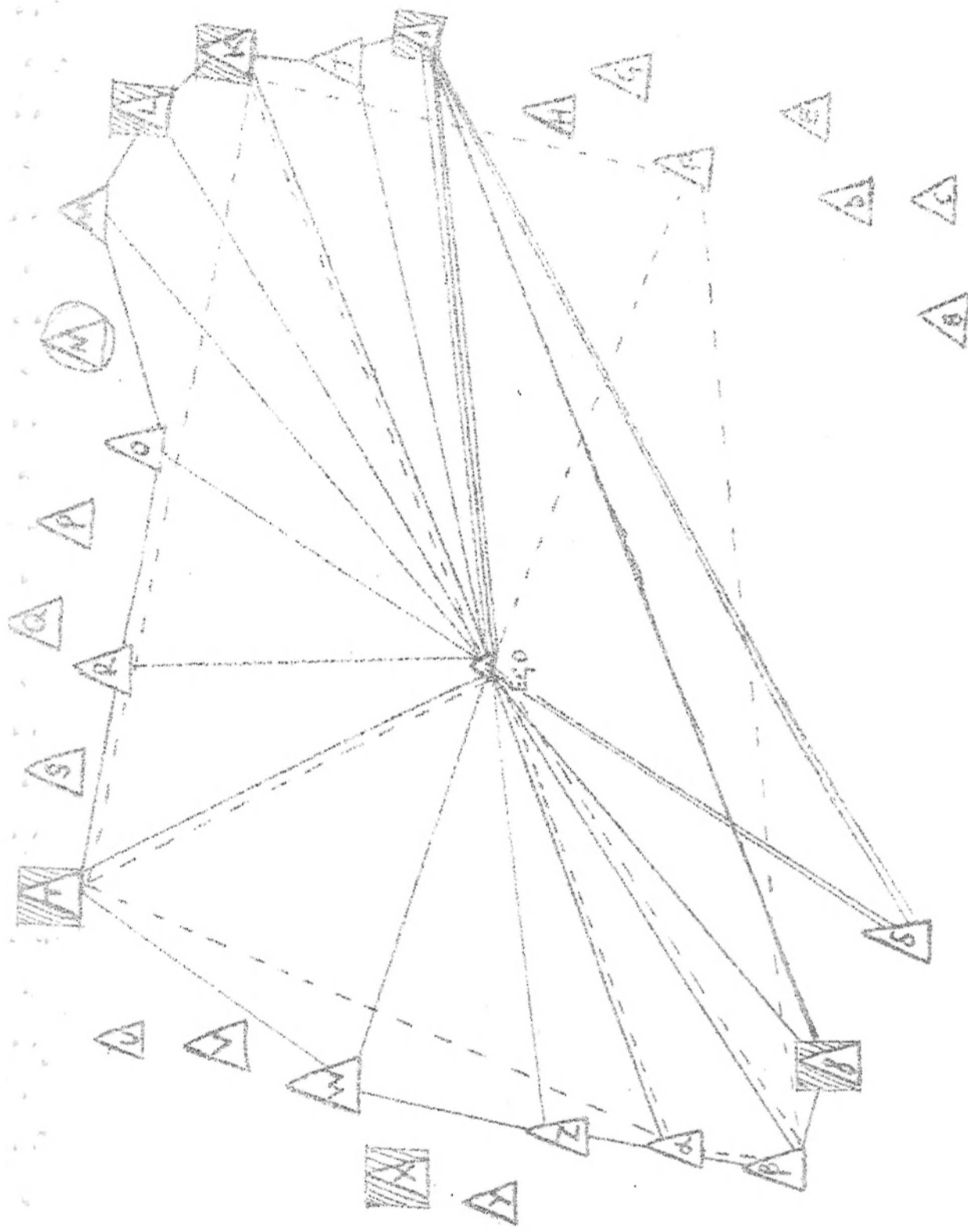

③ EDUCATION AND TRAINING.

- PRIMARY SCHOOL TOGETHER.
- MIDDLE SECONDARY SCHOOL.
- SOCIAL WORK COURSE AND COMMON OCCUPATION.

- △ GRADUATE OR UNDERGRADUATE.

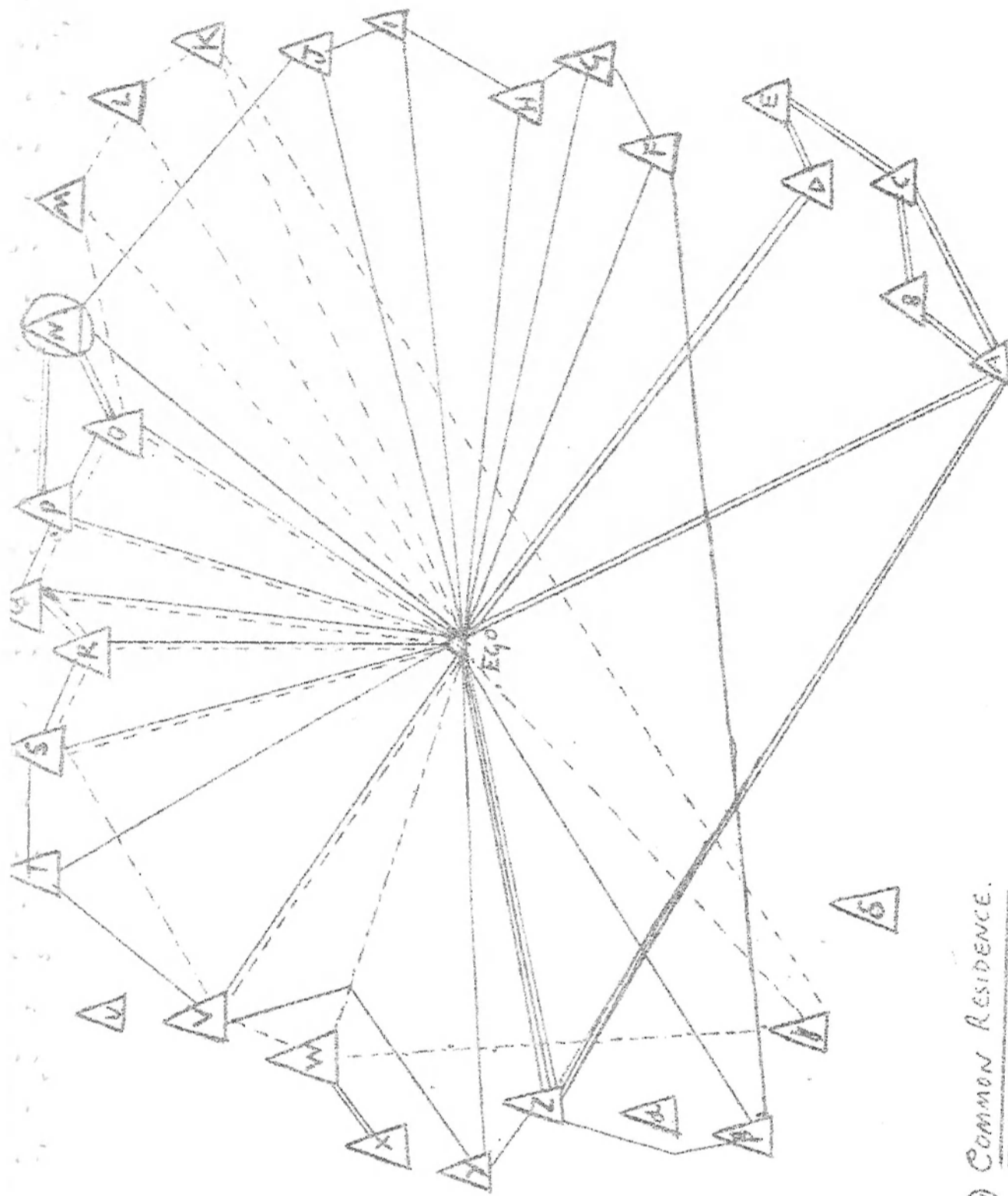

(4) COMMON RESIDENCE.

- ===== SAME HOME AREA / STAY TOGETHER IN TOWN.
- ==== NEW KAMIVAKA SUBURB.
- - - - - LIVINGSTONE AT SAME PERIOD.

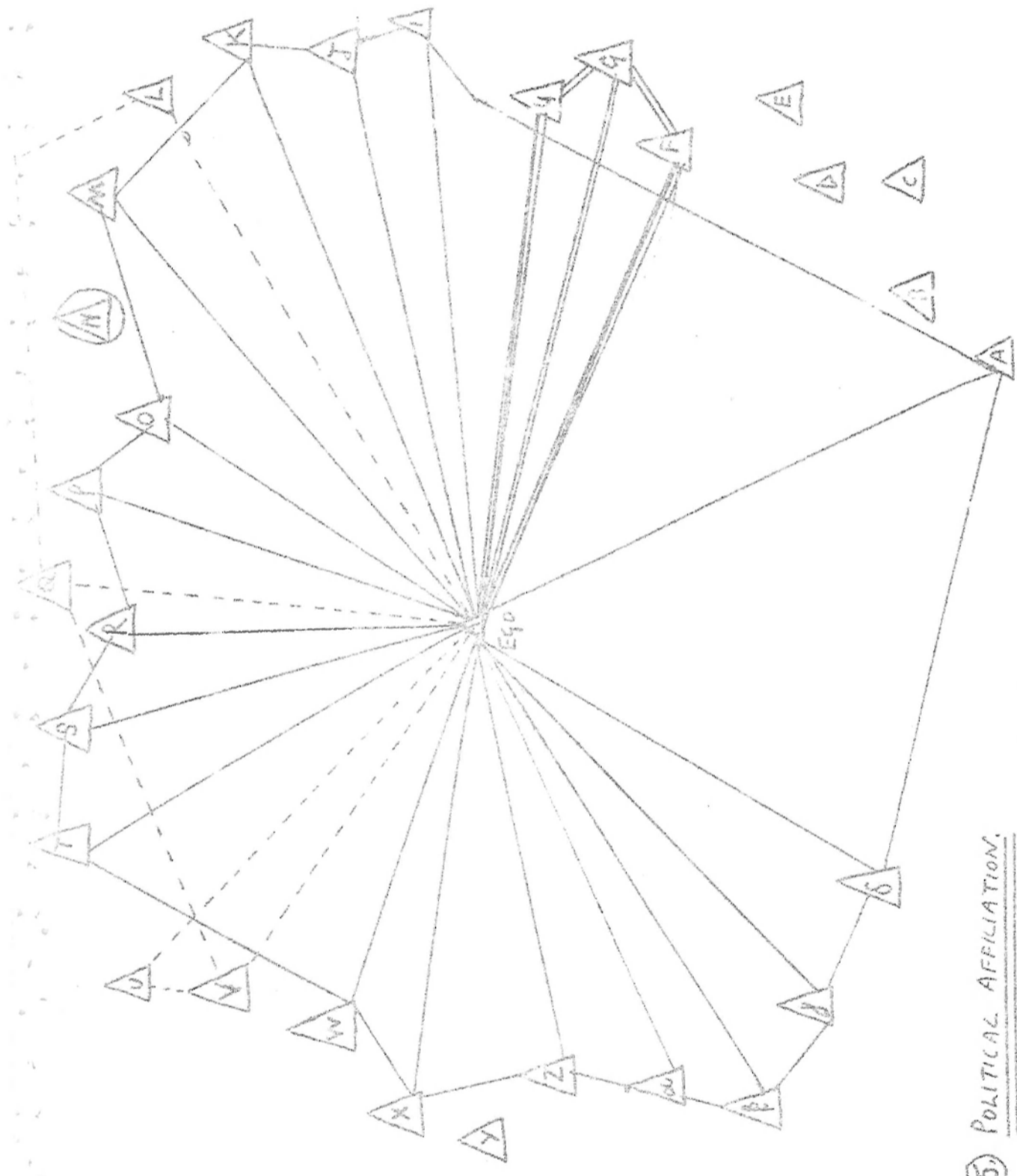

⑤ POLITICAL AFFILIATION.

- ==== Z.A.M.U.
- U.N.I.P.
- R.D.C./A.N.C.

N.B. AFFILIATION DOES NOT IMPLY ACTIVE PARTICIPATION. SEVERAL RHODESIAN REAGENTS ARE Z.A. 20 SYMPATHISERS.

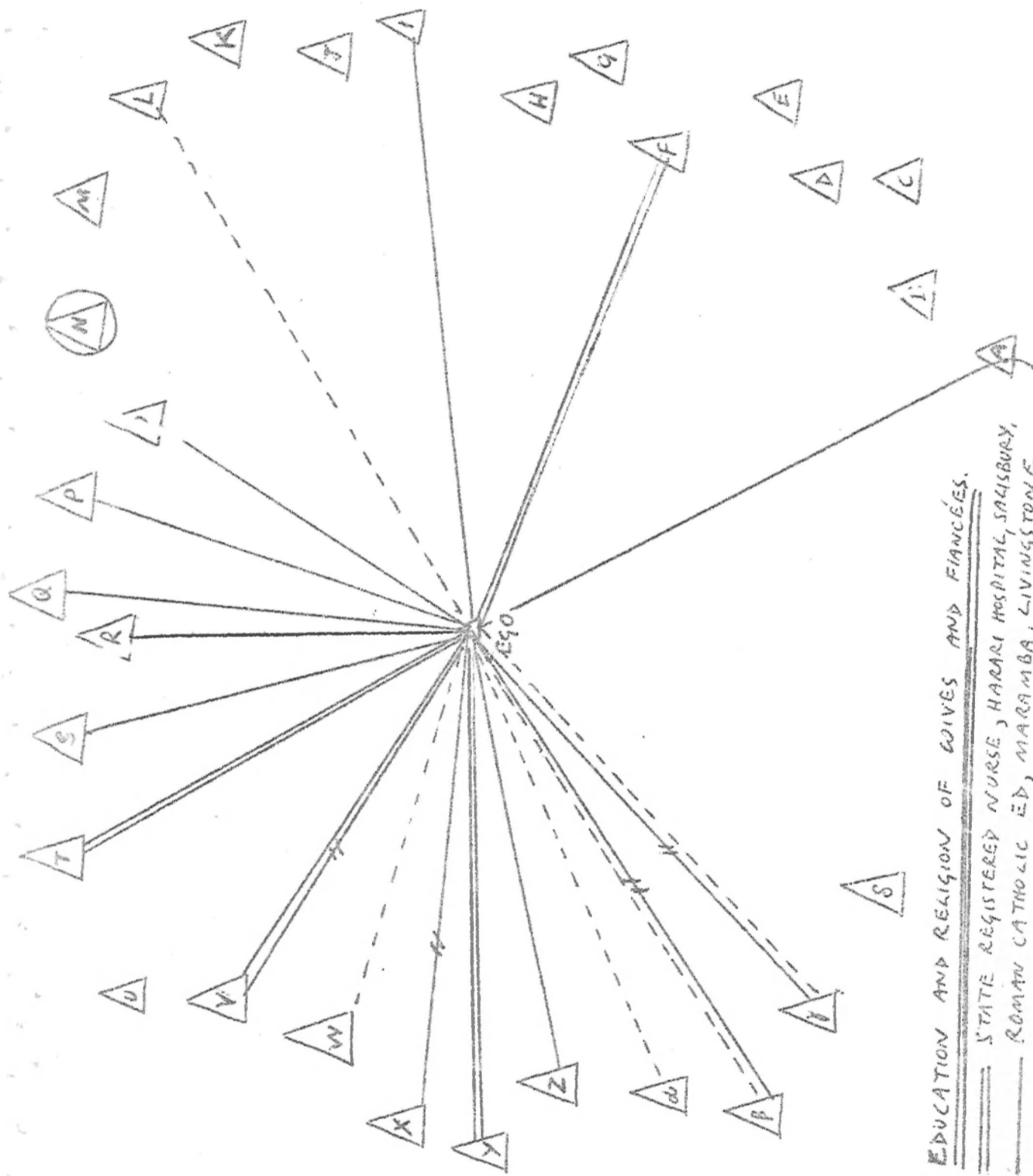

60 EDUCATION AND RELIGION OF WIVES AND FIANCEES.

- ==== STATE REGISTERED NURSE, HARARI HOSPITAL, SALISBURY.
- ==== ROMAN CATHOLIC ED, MARAMBA, LIVINGSTONE.
- PROTESTANT BARRY ED, CHICHEMBI, C. PROVINCE.
- HUSBAND A ROMAN CATHOLIC.

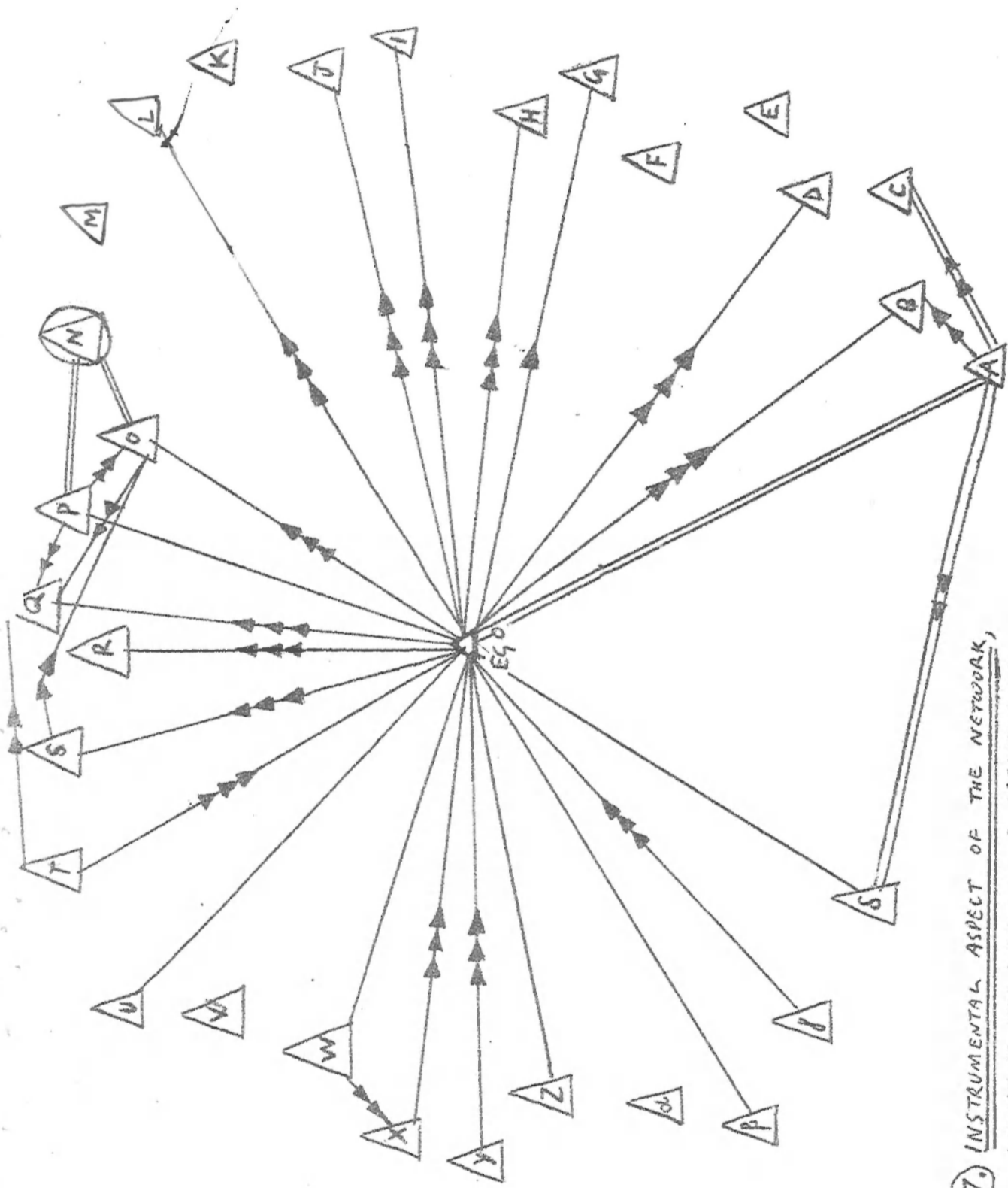

7. INSTRUMENTAL ASPECT OF THE NETWORK,
 INDICATING THE DIRECTION OF GREATEST AID
 AND THE INTERDEPENDANT RELATIONSHIPS, AND
 A LACK OF ARROWS INDICATES FULL RECIPROCY.

9.

SOCIAL AND ECONOMIC STATUS OF NETWORK
MEMBERS RELATIVE TO EGO.

(A) APRIL 1964

(B) DECEMBER 1965

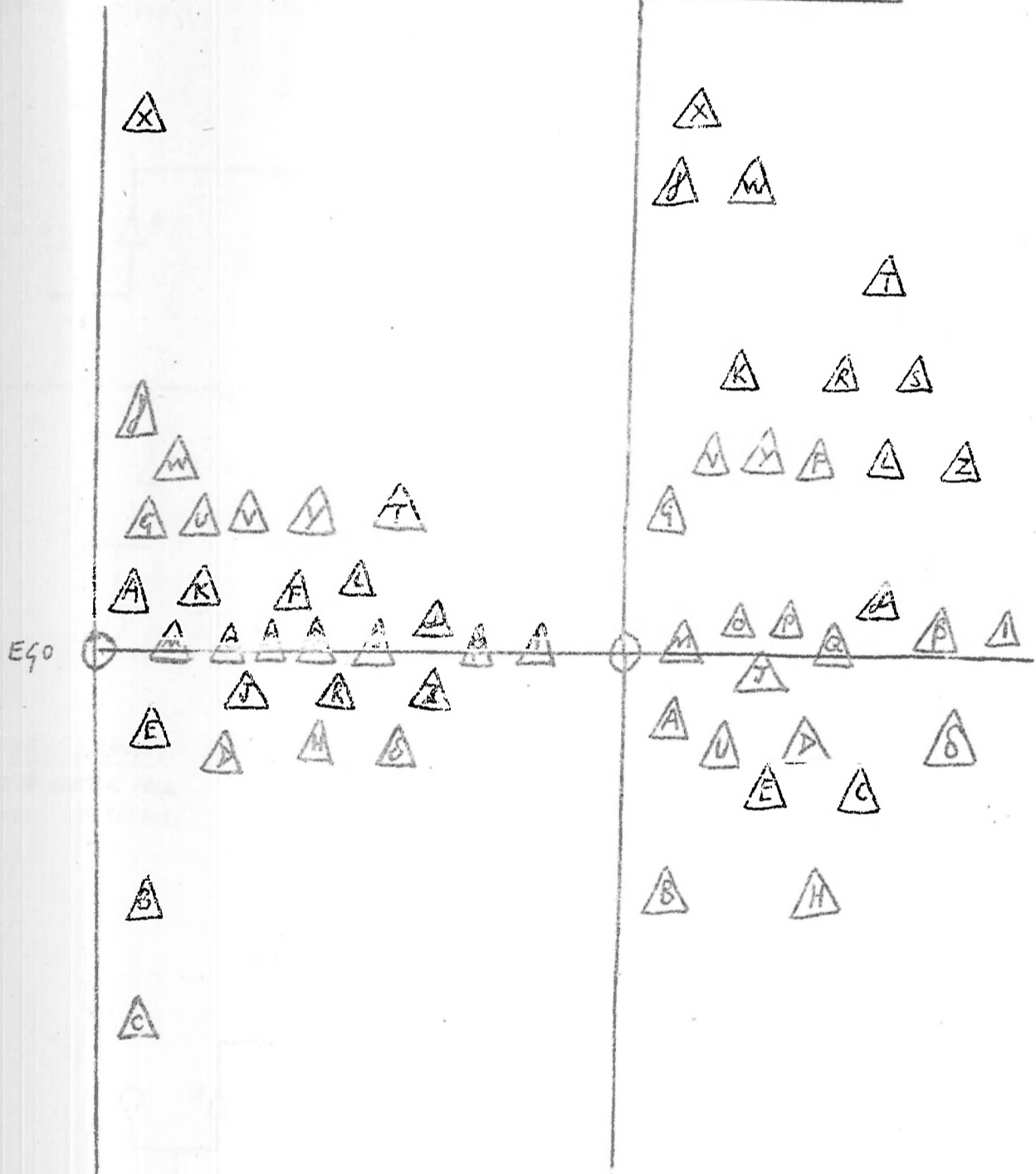

N.B. AN ATTEMPT HAS BEEN MADE TO
COMBINE OCCUPATIONAL PRESTIGE
WITH THE POTENTIALITIES OF
INCOME AND EDUCATION.

N.B. ALTHOUGH EGO'S INCOME HAS BEEN
GREATLY INCREASED, A LOT HAS BEEN
EXPENDED ON HIS FATHER'S FAILURE.

8.

KINSHIP.

(A) SHONA GROUP.
AT AFRIL 1964.

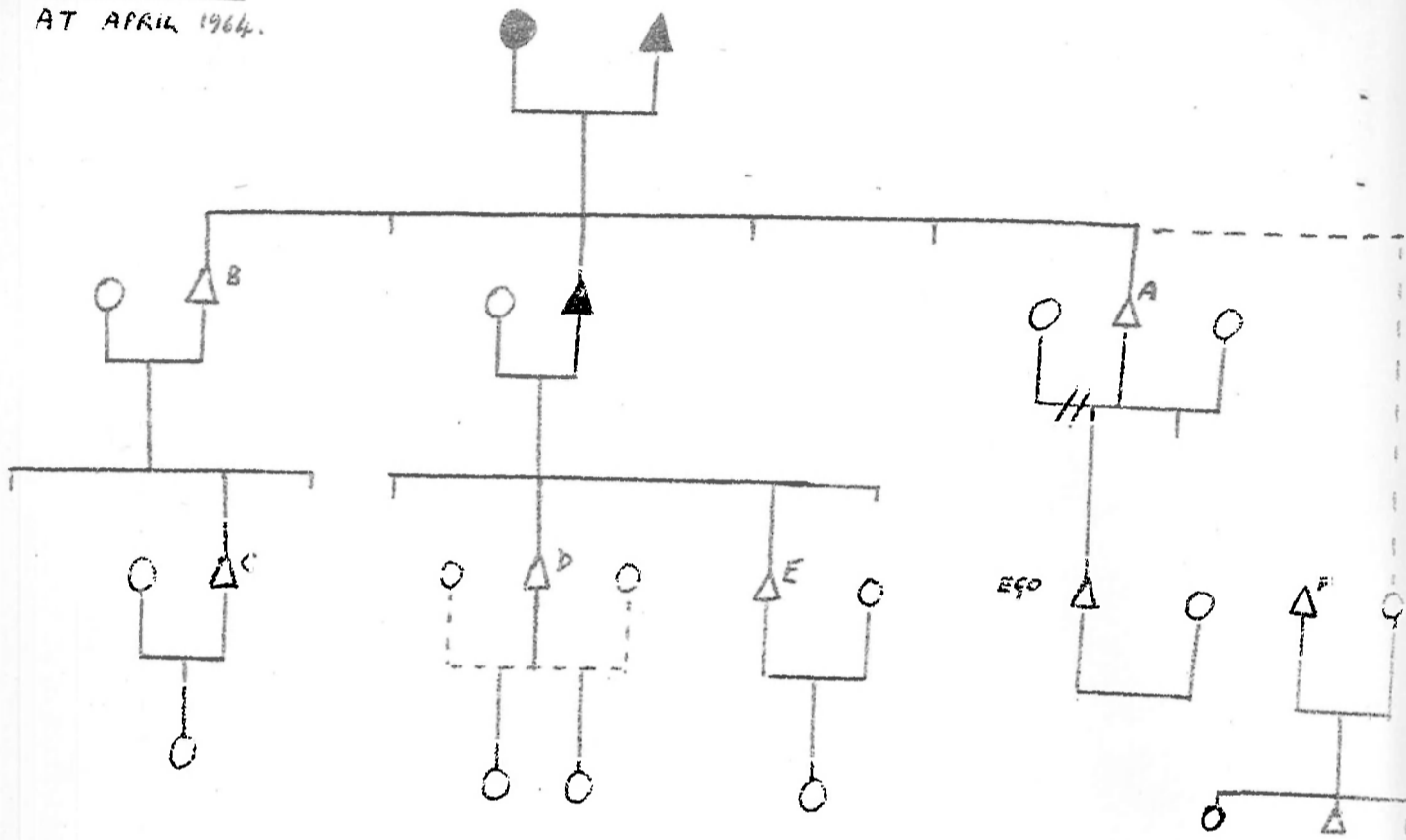

(B) LOZI GROUP.
AT DECEMBER 1964
AFTER THE BIRTHS.

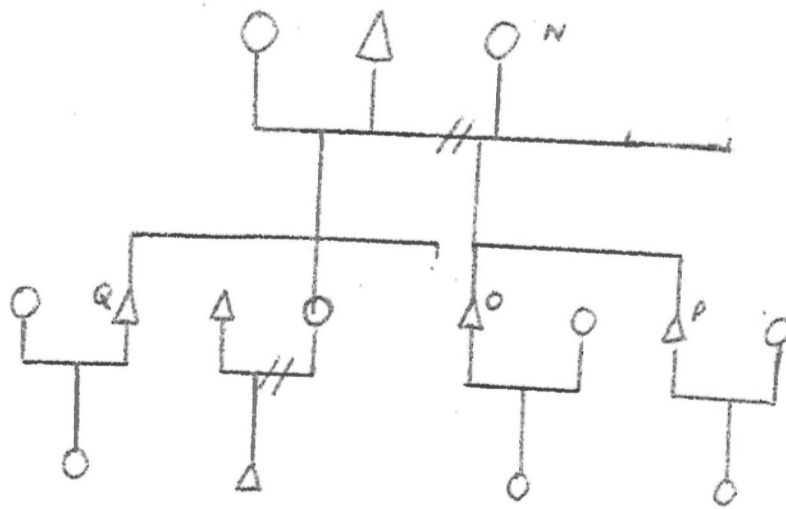

--- PUTATIVE
KINSHIP

--- DIVORCE

--- EXTRA-
MARITAL
LIAISON

A paper for the first Conference of the University (of East Africa)
Social Science Council, held at EAISR, Makerere College, Kampala,
January 3 - 8, 1966

CONCEPTION DES RAPPORTS POLITIQUES AU BURUNDI

Henri-Philippe Cart

Université Officielle de Bujumbura

I. Notre propos, forcément limité, concernera l'évolution des représentations du pouvoir politique, de sa légitimité, et de son organisation. Cet aspect de la question nous semble l'un des plus fondamentaux dans une société comme celle du Burundi. En effet, la nature, l'organisation du pouvoir, de même que sa justification (ou sa contestation) partielle ou totale, consciente ou inconsciente, permettent, à travers les dynamismes issus des trois âges du pays (indépendance traditionnelle, tutelle, indépendance moderne) de dégager certains traits propres de l'idéologie (1) dominante de la société.

Dans cette orientation, les modèles élaborés par David Apter (2) offrent une base adéquate. Cet auteur distingue trois types de société politique nationale dans l'Afrique contemporaine indépendante, fondés sur l'analyse de cinq variables : la légitimité, la loyauté, l'autonomie des décisions, la distribution de l'autorité et l'expression idéologique, évoluant sous l'effet de dynamismes internes et externes.

Le Ghana, par exemple, représente le système de mobilisation (mobilization) dans lequel le parti - cet "organizational weapon" pour reprendre l'expression de P. Selznick - joue le rôle moteur dans la réorganisation fondamentale de la société. L'autorité se concentre dans les mains d'un seul leader qui en lui-même monopolise la légitimité et qui unit la modernité à la tradition par la "sacralisation" de son rôle (l'Osagyfo par exemple). Le parti demande une soumission, une allégeance totale de l'individu; et les organisations, tels les syndicats ou les mouvements de jeunesse, mobilisent le consensus populaire à cet effet. L'expression idéologique est fortement affirmée, elle se veut totale et vient justifier tous les actes de l'administration, dans la mesure où le slogan idéologique devient une forme de communication.

Le deuxième système se caractérise par la large place accordée aux compromis entre groupes qui peuvent présenter un éventail très ouvert d'idées et d'ambitions. Ce système "consociationnel" (consociational) se réalise techniquement par l'assemblage d'unités qui conservent leur identité dans l'union; il s'étend de la vague confédération à la fédération structurée. L'autorité y épouse une forme pyramidale et les loyautés sont multiples. Le consensus politique unifiant s'élabore sur une

(1) "Une idéologie politique est un ensemble d'idées, de représentations, de croyances, propres à un groupe social déterminé, relatives à la structure et à l'organisation présentes et futures de la société globale dont il fait partie" (P. Bonafé et M. Cartry : Les idéologies politiques des pays en voie de développement, in Revue française de science politique, 1962, p. 417)

(2) David E. Apter : The Political Kingdom in Uganda, Princeton 1961, p. 20 ss.

base volontaire et dans l'acceptation de dénominateurs communs et de compromis. L'idéologie y est plus diffuse, quoique nécessaire à cimenter la cohérence des unités constituantes. D. Apter cite par exemple le concept de négritude qui touche plus à l'esthétique et à la morale de la vie africaine qu'à l'idéologie politique proprement dite.

Le troisième modèle est celui de l'autocratie modernisatrice (modernizing autocracy). L'autorité y est hiérarchique, mais étayée par la conception traditionnelle de la légitimité. Elle nécessite de ce fait une homogénéité de la société aux fondements ethniques ou religieux. Ce système absorbe assez facilement le progrès technique, mais éprouve de grandes difficultés à se transformer en gouvernement représentatif, qui pourrait attenter au principe traditionnel de légitimité. Le pouvoir en effet se concentre, comme dans le système de mobilisation, au faîte de la société (le roi généralement), mais alors en vertu du caractère institutionnalisé du rôle de chef. Le titulaire du rôle importe moins que le rôle lui-même dans lequel réside la continuité. Le caractère exclusif de la loyauté à l'égard du chef rend la qualité de membre de la société équivalente à la citoyenneté de l'Etat. Ce système tend à être unitaire, car, si le pouvoir est partagé, il ne l'est qu'à titre précaire, le roi pouvant toujours reprendre ce qu'il a distribué. L'idéologie est néo-traditionaliste : elle applique les préceptes moraux traditionnels aux situations et aux conditions modernes; elle est suffisamment souple pour permettre que l'innovation soit "traditionnalisée" (et par là même, la tradition petit à petit modifiée).

Cette typologie, trop sommairement présentée, va permettre de dégager - à travers les structures traditionnelles, les formes de stratification sociale sur lesquelles elles reposent, et la dynamique des changements sociaux - l'évolution des représentations du pouvoir et de sa légitimité - et partant, les modifications portées à son organisation - dans le seul royaume d'Afrique noire qui, en tant qu'Etat souverain, a survécu à la période coloniale.

II. Culturellement le Burundi appartient, au sein des civilisations interlacustres, au groupe Nyoro-Ha et au sous-groupe Rwanda-Ha. Les trois principales sociétés de ce sous-groupe (Rwanda, Burundi, Buha) se signalent par un phénomène très particulier : "C'est l'existence à l'intérieur d'une unité culturelle aussi remarquable de systèmes politiques aussi divergents actuellement" (1).

Au moment de l'arrivée des premiers Européens (1871-1895), la structure politique des trois Etats divergeait déjà fortement : le Buha avait éclaté en une multitude de chefferies qui perdirent toute originalité politique au sein du Tanganyika Territory. Le Rwanda avait amorcé une concentration des pouvoirs dans la personne du roi, et c'était chose faite au milieu du 19e siècle; à quelques territoires près, sous le règne de Kigeri IV Rwaabugiri. Le Burundi, par contre, connut des tensions structurelles très fortes : comme le code érotérique ne semble pas avoir désigné avec précision quel fils succède à son père, la mort d'un roi entraînait toujours une âpre compétition entre ses fils. Celle-ci était tempérée par le fait qu'un roi devait être un enfant ou au plus un adolescent au moment de son accession au trône et qu'il était assisté d'un

(1) J. Vansina : Introduction générale à : M. D'Hertefeldt, A.A. Trouwborst et J.H. Scherrer : Les anciens royaumes de la zone interlacustre méridionale, Tervuren 1962 p. 5

conseil de régence formé de sa mère et de certains de ses oncles ou de ses frères aînés qui, s'ils ont vu leur échapper le titre de roi, n'en jouent pas moins le rôle pendant quelques années. Le roi devenu adulte devait affirmer son autorité face à tous ceux qui avaient profité de sa minorité pour relâcher les liens qui les unissaient au pouvoir central (1). Ainsi le roi Ntare IV, ayant conquis d'importants territoires, les fit administrer par ses fils aînés; celui de ses fils devenu roi sous le nom de Mwezi IV Gisabo connut alors pendant tout son règne (1852-1908) la rébellion de plusieurs membres de sa famille contre son autorité. L'occupant allemand qui au départ encouragea les dissidences, alla jusqu'à reconnaître simultanément trois rois (2).

Cet équilibre, ou plutôt ce système balancé, qui empêchait la concentration du pouvoir, était complété par le jeu des stratifications sociales. En effet, si dans le Rwanda ancien le Tutsi était quasi toujours le supérieur et le Hutu l'inférieur, il serait hatif de transposer cette relation telle quelle au Burundi. Les rapports sociaux et économiques y étaient effectivement dominés par le contrat de bail à cheptel, dit d'ubugabire, qui faisait des Hutu les clients des Tutsi; l'ubugabire était cependant une forme atténuée de l'ubuhake du Rwanda (3). D'autre part, la stratification sociale y était plus complexe: la famille royale qui - affirme Trouwborst - "n'est généralement pas considérée comme Tutsi et il y a même des traditions qui disent que les rois sont d'origine Hutu" (4), les princes ou Ganwa (5), les Tutsi, les Hutu et les Twa. Cette hiérarchie sociale s'est petit à petit atténuée devant la hiérarchie politique dont la souplesse était beaucoup plus grande. En effet, "dans le système politique, ce sont le roi et les princes - le Mwami et les Ganwa - qui sont les vrais supérieurs permanents. Les Tutsi et les Hutu sont leurs sujets. Un Hutu peut même espérer, s'il est d'une bonne famille, ou d'une très grande valeur comme guerrier ou devin, occuper un rang supérieur à un Tutsi. Il y a donc bien deux catégories nettement distinctes, celle du supérieur et celle de l'inférieur, mais on ne peut pas dire quel homme se trouvera dans l'une ou l'autre à un moment donné." (6)

(1) cf. A.A. Trouwborst : op. cit. p. 153

Eugène Simons : Coutumes et institutions des Barundi, in Bulletin des juridictions indigènes et de droit coutumier congolais, 1944 p.194

(2) E. Simons : op. cit. p. 145 ss.

(3) cf. J.J. Haquet : La participation de la classe paysanne au mouvement d'indépendance au Rwanda, in Cahiers d'études africaines, 1964 vol. 16 p. 556

(4) A.A. Trouwborst : op. cit. p. 20; à la suite de plusieurs auteurs

(5) Les princes sont les descendants d'un roi; ils conservent le titre de princes et les prérogatives qui y sont attachées pendant quatre générations (c'est-à-dire jusqu'à ce qu'un roi homonyme de leur ancêtre monte sur le trône); à la suite de quoi, ils sont automatiquement déçus au rang de Bapfasoni, c'est-à-dire "de bonne famille", et prennent un autre nom de famille. Exemple : Les descendants de Ntare III, appelés Batare, sont des Ganwa durant les règnes de Mwezi III, de Mutaga III et de Mwambutsa III, et deviennent Bapfasoni à l'avènement de Ntare IV. Il peut donc y avoir au maximum quatre familles de princes: les Batare, les Bezi, les Bataga et les Banbutsa.

(6) Ethel M. Albert : Une étude de valeurs en Urundi, in Cahiers d'études africaines, 1960 vol. 2 p. 152.

Si J.J. Maquet a pu caractériser les rapports socio-économiques entre Tutsi et Hutu au Rwanda de castes à vocation de classes sociales, entendant par caste la situation où "tout membre de la société fait nécessairement partie d'une des couches et uniquement d'une seule" (1), la souplesse des rapports socio-politiques au Burundi, par opposition aux structures "bloquées" du Rwanda, conduisait plutôt à une lente fusion des strates et à une société plus homogène. Ce processus évolutif était en outre renforcé par les profonds antagonismes qui à la fin du 19^e siècle divisaient les Ganwa, et empêchaient ainsi la formation - ou le maintien ? - d'une solidarité de caste politique dirigeante.

La justification idéologique de ces hiérarchies - partant d'un principe général commun au Rwanda et au Burundi : Imana (Dicu) est la force supérieure qui dispose de tout et ordonne tout, la nature, la société, la vie; et le Mwami (roi), d'origine divine, est le représentant terrestre d'Imana (2) - suivra des voies divergentes dans la mesure où les relations sociales et politiques reflétées divergent elles-mêmes. Alors qu'au Rwanda l'idéologie de la caste dominante s'affirmait et se complétait en même temps que cette domination s'étendait, au Burundi la décentralisation, la contestation du pouvoir central par quelques Ganwa, la mobilité politique dans l'administration du pays, la précarité du titre et des fonctions de prince, conduisaient en quelque sorte à une déperdition de l'idéologie justificatrice du pouvoir.. Ainsi à titre d'exemple : "Bien qu'il jouit en théorie de pouvoirs absolus, le Mwami du Burundi était en fait primus inter pares parmi les princes du sang (Ganwa)" et "en fait, l'organisation traditionnelle du Burundi, telle qu'elle nous apparaît au terme de son évolution précoloniale, se différencie de celle du Rwanda dans la mesure où une féodalité non-étatique se différencie d'une féodalité étatique"(3).

Ces imbrications extrêmement délicates entre deux ordres - l'ordre social plus figé où l'idéologie traditionnelle reste assez vivante, et l'ordre politique et administratif beaucoup plus souple où le pragmatisme semble parfois l'emporter - constituent au sein de la société du Burundi un dynamisme social particulièrement agissant et accueillant aux innovations que les contacts avec le monde extérieur (tutelle) vont apporter.

III. Si les premiers résidents allemands au Burundi commencèrent par soutenir les sécessions à l'égard de l'autorité centrale, ils finirent par reconnaître la seule autorité du Mwami Mwezi IV Gisabo. Après le bref règne de Mutaga IV (1908-1915), le Mwami actuel Mwambutsa IV, âgé alors de 3 ans, fut proclamé souverain du pays en 1915. L'autorité centrale était encore faible lorsque les forces belges occupèrent le pays en 1916. Certains grands feudataires se replièrent provisoirement avec les Allemands, malgré le ralliement du roi et de la cour au nouvel occupant. Il fallut plusieurs années pour que tous les Banwa reconnaissent l'autorité du Mwami Mwambutsa IV.

(1) J.J. Maquet : op. cit. p. 558

(2) Plusieurs traits des coutumes du Burundi traditionnel se rapprochent fortement de la notion de roi "source de vie" du royaume Nyoro (cf. John Beattie : Bunyoro. An African Kingdom, New York 1960) - Il faut souligner cependant que certaines traditions ne parlent pas de l'origine divine de la dynastie. On peut penser que les traditions du Burundi qui donnent à la dynastie la même origine que celle de la dynastie du Rwanda, sont inspirées par la tradition rwandaise. Quoi qu'il en soit de son origine, le Mwami agit au Burundi en tant que représentant d'Imana lors de plusieurs fêtes traditionnelles (ex.: Umuganuro, fête des semailles et de la fécondité).

(3) R. Lemarchand : L'influence des systèmes traditionnels sur l'évolution politiques du Rwanda et du Burundi, in Rev. de l'Inst. de sociologie 1962 p. 336 - Soulignons toutefois que le terme "féodalité" est inadéquat dans la mesure où il fait penser à la société européenne du Moyen-Âge.

La Belgique poursuivit, lorsque la Société des Nations lui eut confié un mandat sur le pays (1), une politique d'administration indirecte et de renforcement du pouvoir royal au détriment des grands feudataires, et cela par souci de "simplifications administratives" et d'ordre. Toutefois, les autorités traditionnelles du Burundi, rendues méfiantes à l'égard de l'occupant européen depuis les tentatives de manipulation commises par les premiers résidents, adoptèrent une attitude assez passive. Ainsi les écoles pour fils de chefs, au programme inspiré par la tradition, suscitèrent des réactions très tièdes. Si au Rwanda de telles écoles accueillèrent largement et exclusivement les fils de chefs Tutsi, il semble qu'au Burundi elles aient dès le départ connu un recrutement plus démocratique (2), malgré la politique scolaire de la Belgique qui désirait favoriser avant tout "presque exclusivement la caste Tutsi, et plus précisément les membres de cette caste investis de fonctions administratives." (3)

En outre, la diversité des pouvoirs politiques et administratifs traditionnels rendait l'emprise de la tutelle beaucoup plus malaisée qu'au Rwanda, et le système d'administration indirecte y fut moins poussé. Les autorités traditionnelles conservaient toutefois un certain exercice du pouvoir. Mais le fait colonial qui par ailleurs introduisait de nombreux processus de socialisation, bloquait les dynamismes socio-politiques sous trois aspects au moins : - en premier lieu, le désir de voir régner l'ordre a naturellement incité les autorités de la tutelle à stabiliser le pouvoir des chefs en place et à favoriser l'éducation de leurs fils; - en deuxième lieu, ce même désir d'ordre aboutit à "geler" les problèmes politiques qui n'étaient pas résolus au début du siècle ou qui surgirent depuis lors; - en troisième lieu, l'intervention de l'autorité administrante était exclusive dans les domaines de nature moderne. Cette situation, propre à des nuances près à toute société dominée, a provoqué une certaine dépolitisation des autorités autochtones.

La suppression du contrat d'ubugabire (bail à cheptel) et la municipalisation des pâturages ont d'autre part contribué à démanteler l'organisation sociale traditionnelle dans ce qu'elle avait d'institutionnalisé. Toutefois la suppression juridique d'un contrat ne modifie pas des relations sociales bien établies de client à patron; elle permet simplement à celui qui le désire de nouer d'autres relations sociales (la rupture du contrat d'ubugabire était d'ailleurs déjà admise par la coutume du Burundi).

La mise en place de conseils (sous-chefferie, chefferie, territoire, pays) en 1952 par un système d'élection sur liste bloquée et de cooptation, puis les élections de 1956, lors du renouvellement des différents conseils, permirent pour la première fois au peuple (uniquement les hommes) de se prononcer sur leurs représentants. Le système adopté eut pour conséquence d'atténuer très fortement le processus démocratique à l'échelon supérieur (4), alors que les conseils de sous-chefferies s'ouvraient à de nombreux représentants nouveaux. Si la composition de ces différents conseils ne laisse pas apparaître à l'échelon supérieur de différences quantitatives marquées par rapport aux institutions similaires du Rwanda, il faut souligner qu'en réalité ces rôles institutionnalisés se différencient par la façon dont leurs titulaires en ont fait usage... Les Bani (rois) du Rwanda et du

(1) transformé en tutelle par l'ONU

(2) En 1928, l'école de Gitega comptait 50 fils de chefs, 67 Tutsi et 53 Hutu. cf. Rapport sur l'administration du Ruanda-Urundi en 1928, Bruxelles 1929 p. 53

(3) R. Lemarchand : op. cit. p. 343

(4) cf. M. D'Hertefeldt : Les élections communales et le consensus politique au Rwanda, in Zaïre, vol. XIV 1960 p. 403-438
Cf. J.J. Maquet et M. D'Hertefeldt : Elections en société féodale, Académie royale des sciences coloniales, T. XXI fasc. 2, Bruxelles 1959

Burundi étaient respectivement présidents des Conseils supérieurs des Pays, mais tandis qu'au Rwanda la personnalité de Mutara y exerçait une influence conservatrice et traditionaliste, celle de Mwanbutsa y imprimait un élan progressiste et modernisateur." (1)

Bien qu'aucun parti politique ne soit apparu à ces occasions, cette procédure introduite par les autorités de la tutelle mit en branle les esprits jusque dans le "petit peuple". Peut-être pour la première fois, celui-ci ressentit les profonds changements sociaux intervenus et, sans qu'il sentit le besoin d'affirmer son originalité (l'homogénéité croissante de la société ne l'y poussait pas), il prit conscience à partir de ce moment d'une certaine atomicité de la société, tout en conservant par tradition un profond respect pour ceux qui avaient occupé ou occupaient des fonctions dirigeantes, et tout particulièrement pour le roi dont l'autorité intouchée continuait à se justifier par elle-même.

Au moment de la pré-indépendance, la situation pouvait être caractérisée ainsi : - la hiérarchie sociale voyait toujours le roi et les Ganwa à sa tête, mais les rapports hiérarchiques entre Tutsi et Hutu allaient s'ameublissant, les Twa pygmoides (1 % de la population) restant manifestement à l'écart et en état de nette infériorité; - la hiérarchie politique et administrative conservait le roi à sa tête; le rôle des Ganwa était encore grand, mais ils n'étaient pas les auxiliaires quasi obligés du pouvoir royal; un corps de fonctionnaires assez important s'était formé, recruté essentiellement parmi ceux qui avaient fréquenté l'une des sections du "Groupe scolaire d'Astrida" (2). La fréquentation de cette école n'était pas chassée gardée : si les fils des élites traditionnelles y étaient bien représentés, les Hutu et les Tutsi de condition modeste y étaient aussi nombreux.

A ce stade de l'évolution des changements socio-politiques, il apparaît que le modèle d'"autocratie modernisatrice" permet de suivre la conception du pouvoir généralement admise au Burundi, les prémisses à ce modèle (3) étant assez bien satisfaites : soit d'une part une forme hiérarchique d'autorité, sans source de pouvoir intermédiaire relativement autonome, et d'autre part un ensemble de rôles et d'institutions dont l'orientation peut être qualifiée d'"instrumentale" par opposition à "consommatoire".

IV. La naissance des partis politiques date du moment où l'indépendance apparut à l'horizon, soit de 1958 pour les premières entrevues préparatoires et de fin 1959 et début 1960 pour la fondation effective des premiers partis. L'élan donné, le mouvement allait s'accroître : en l'espace de 15 mois, 23 partis étaient fondés et reconnus par la tutelle. Cette pléthore soudaine s'explique pour plusieurs raisons :

- Une méconnaissance des opinions d'autrui, dans la mesure où l'habitat isolé ne facilite pas les contacts. Ainsi plusieurs petits partis ont été fondés en des lieux divers avec des programmes et des intentions identiques; souvent ils se sont regroupés au moment où ils ont pris conscience de leur existence respective, ou alors ont conservé une implantation très régionale. Ce phénomène se remarque surtout dans les partis fondés par des personnes qui n'avaient pas encore accédé à des responsabilités importantes et qui de ce fait avaient peut-être peu voyagé et discuté.

(1) R. Lemarchand : op. cit. p. 345

(2) Les commissariats au Pays, créés en 1960, étaient dirigés par 9 commissaires; 8 avaient passé par cette école, et le dernier par le petit séminaire (petits et grands séminaires ont d'ailleurs joué un rôle également important).

(3) D.E. Apter : op.cit. p. 27 et 442 ss.

- La renaissance de problèmes politiques "gelés" pendant la période coloniale : les rivalités entre les souches princières des Batare (descendants du Mwami Ntare IV, à l'exception de son fils devenu roi sous le nom de Mwezi IV) et des Bezi (descendants du Mwami Mwezi IV; son fils, roi sous le nom de Mutaga IV, mort jeune, n'a laissé que deux descendants mâles; aussi sont-ils considérés comme Bezi et non comme Bataga) qui avaient mis en péril l'unité du royaume à la fin du 19^e siècle et au début du 20^e, ressurgissent en quelque sorte dans la création du parti UPRONA (Unité et progrès national) dont le conseiller était le Prince Rwagasore, fils aîné du roi et représentant des Bezi, et du parti PDC (Parti démocrate chrétien) dirigé par les membres influents des Batare.

- Certains leaders traditionnels formèrent leur propre parti, peut-être pour créer une troisième force médiatrice entre l'UPRONA et le PDC. Ainsi le Parti Démocrate Rural animé par M. Pierre Bigayimpunzi, descendant du Mwami Mwezi. - Les milieux urbains, qualifiés à l'époque d'"évolués", formèrent aussi leurs partis; la faiblesse numérique de ces milieux mêmes les empêcha de prendre une importance très grande.

Il est certain que la proximité de décisions politiques importantes (élections, autonomie, indépendance) provoqua une grande hâte, sans laquelle la plupart des partis n'auraient pas vu le jour. Il est d'ailleurs significatif que les premiers partis constitués sont ceux qui se sont imposés aux premières élections; ils avaient en quelque sorte monopolisé les cadres du pays en leur sein.

Tous les partis se retrouvaient pour admettre le principe de la légitimité monarchique, mais leurs déclarations montraient bien que cette légitimité était depuis longtemps désacralisée, au moins dans l'esprit des cadres du pays. Ainsi l'UPRONA soutenait le régime monarchique "pour autant que celui-ci et la dynastie qui le représente, soient pour l'émancipation réelle du peuple burundi, pour la paix et la prospérité du Burundi." (1)

Moutefois, l'insistance mise par le PDC et les partis qui se regroupaient autour de cette formation, à obtenir que le Prince Rwagasore s'abstienne de toute politique, lui qui était la figure de proue de l'UPRONA, est une preuve évidente de l'autorité dont le Prince jouissait auprès des masses, surtout en sa qualité de fils aîné du roi. Le petit "Parti de la Voix du Peuple burundi" éclairait bien la question en déclarant : "Nous distinguons trois aspects dans la personne du Muganwa Rwagasore : Rwagasore fils du Mwami, Rwagasore umwazi et Rwagasore chef investi. En tant que fils du Mwami, il convient qu'il ne joue pas de rôle politique, pour sauvegarder la dignité dynastique; en tant qu'umwazi, vouloir l'écarter de la politique c'est vouloir favoriser les Batare au détriment des Bezi, et dans ce cas la paix nationale en pâtirait; en tant que chef investi, l'on écarter nécessite l'exclusion de tous les autres chefs de la politique." (2)

Au colloque de Bruxelles qui réunissait les délégués des principaux partis du Burundi et les représentants de la Belgique (août 1960), la majorité des partis admit le principe suivant : "Les parents et alliés du Mwami jusqu'au 2^e degré ne peuvent recevoir de mandat électif, ni exercer des fonctions politiques, ni participer à une activité politique. Les membres (du colloque) expriment d'autre part le vœu de voir ces parents et alliés se préoccuper de tout ce qui concerne le développement économique, social et culturel du pays." (3) Le refus du Prince de se soumettre entraîna sa mise en résidence surveillée jusqu'à la fin des élections communales (novembre 1960).

(1) M. Lechat : Le Burundi politique, Service de l'information du Rwanda-Urundi, Bujumbura, 1961 p. 20

(2) Rudipresse no. 167 du 30 avril 1960

(3) M. Lechat : op. cit.

Le Roi lui-même, en tant que roi de tous les Burundi, devait être en-dessus de la politique, comme le rappelait le Front commun (PDC et alliés) à la veille des élections : "La plus haute autorité du pays ne peut être entraînée dans la lutte politique, sans que la personne du Mwami, et l'institution monarchique elle-même, n'en soient affaiblies."(1)

Cette "constitutionnalisation" avant la lettre de la famille royale qui avait pour but de mettre les partis politiques sur un pied d'égalité (en réalité, elle défavorisait l'UPRONA), allait et va à l'encontre de la conception populaire de l'autorité royale : pour les masses, le roi reste le père et le guide de la nation. Cette ambiguïté du rôle royal va peser sur la vie politique des premières années de l'indépendance.

Les programmes des différents partis reflètent leur jeunesse et la nouveauté des problèmes sur lesquels ils sont appelés à se prononcer : aucun ne se prétend féodal (puisque la féodalité étatique n'est pas dans la tradition du Burundi) et ne l'est en réalité; ils sont tous donc pour la démocratie et désirent la promotion de toutes les couches de la population, le développement économique, ... sans que leurs programmes dépassent le niveau des généralités généreuses.

Le principal point de division apparente réside dans les étapes à parcourir pour accéder à l'indépendance : l'UPRONA, résolument nationaliste, la désire dans les délais les plus brefs après une courte autonomie interne; à l'opposé, le PDC insiste sur la nécessité de démocratiser les institutions avant l'indépendance et "pour cela, ne pas hâter celle-ci, s'allier aux partis démocratiques, appuyer les efforts de l'administration (belge) dans le sens démocratique, disant que le départ prématuré des Européens signifierait le retour aux exactions et aux misères d'antan."(1). Les partis qui se réclamaient du "petit peuple" adoptaient une attitude semblable, dans l'idée que la tutelle pourrait les favoriser.

Les récents événements rwandais (coup d'Etat des partis Parmehutu et Aprosoma, et proclamation de la République) ne manquent pas d'avoir une certaine influence sur l'attitude des partis du Burundi. Les partis du "petit peuple" se regroupent en une "Union des partis populaires" (UPP) qui fait penser aux partis Hutu du Rwanda, sans toutefois que l'UPP mène une politique ethnique avouée; elle continue de travailler avec le PDC. De même, les grands partis ne reflètent pas une ethnie : chacun compte parmi ses membres et ses dirigeants des Ganwa, de nombreux Tutsi et Hutu. Il est certain que les événements et les troubles du Rwanda ont retenu (provisoirement du moins) ceux qui éventuellement auraient cédé à la tentation d'opposer publiquement les ethnies - ce qui en ce moment-là n'aurait pas véritablement reflété l'évolution du Burundi.

Les deux grands regroupements de partis, sous l'égide respective de l'UPRONA et du PDC, se différencient également par leur "style" qui reflète des attitudes plus vécues qu'élaborées.

Le Front commun, dans le sillage de son chef de file le PDC, adopte un ton très modéré de franche collaboration avec les autorités de la tutelle (qui la lui rendent bien). L'UPRONA par contre s'affiche nationaliste et développe des contacts avec d'autres partis nationalistes africains. Ainsi la présence de dirigeants de l'UPRONA, invités par le Mouvement National Congolais de Patrice Lumumba aux fêtes de l'indépendance du Congo, lui aliène la sympathie des autorités de la tutelle (2). Le caractère nationaliste l'emporte

(1) M. Lechat : op. cit.

(2) cf. la façon dont ces contacts sont rapportés dans l'opuscule officiel rédigé par M. Lechat.

toutefois sur une solidarité internationale : ainsi l'UPRONA se distance de l'"Union nationale africaine du Rwanda-Urundi" qui regroupe les Burundi qui, lors d'émigrations temporaires, sont devenus membres de la TANU du Tanganyika. La mise en résidence surveillée du Prince Rwagasore ne fait qu'accentuer l'opposition de l'UPRONA à l'autorité tutélaire : "Le Gouvernement belge ne l'aime pas parce qu'il croit que Rwagasore est le seul capable d'enlever le pain de la bouche des Européens." (1) Dire que l'UPRONA est "anti-blanc", comme on n'a pas manqué de le faire, paraît simpliste; le ton violent parfois employé (2) est l'expression-même de la pensée nationaliste outragée : l'UPRONA cherche, à travers la dynastie, à affirmer la continuité de l'histoire du Burundi : certains rappels de la grandeur de Mwami Mwezi IV Gisabo, de règles coutumières (3), de l'originalité de la culture du Burundi qui ne peut assimiler tels quels tous les concepts européens, la place malgré tout privilégiée qu'occupe le Prince Rwagasore parmi les Ganwa, font que la mise à l'écart de celui-ci a été assurément ressentie comme une atteinte autant à la tradition nationale retrouvée qu'au parti lui-même.

Au niveau du langage également - du moins pour les textes rédigés en français ou traduits du kirundi - une différence semblable se manifeste. L'UPRONA dont le sigle contient les deux piliers de sa doctrine "Unité et Progrès national" utilise un vocabulaire très percutant qui tend à créer une mystique du progrès. Le système qui réalisera ce progrès n'est pas précisé : il s'agira certainement d'une voie nationale puisque l'UPRONA "combatera avec force et ténacité toute injustice sociale, dans le pays, de quelque système qu'elle provienne : féodalisme, colonialisme, communisme." (4) La raison principale du dépouillement de cette perspective doit être certainement attribuée à la jeunesse du parti qui crée, à l'aide de quelques exemples, une mystique progressiste dont le cadre et le contenu se préciseront par la suite.

Le terme de "parti" utilisé par la plupart des groupements politiques, est en quelque sorte impropre. Sans correspondre à de "simples clientèles groupées auprès d'un personnage influent" ou à des "clans constitués autour d'une famille féodale" (5), les principaux partis présentent néanmoins cette caractéristique à des degrés plus ou moins prononcés. Dans la masse électorale paysanne, l'audience d'un parti à l'échelon national dépend de la notoriété de son leader principal. Par contre, pour ceux qui ont accédé à la formation professionnelle et qui forment la nouvelle élite, l'importance de cet aspect est compensée par une perception personnelle des problèmes nationaux; l'engagement politique interviendrait alors plus directement et ne se fait plus par le détour d'un loyalisme à l'égard d'un leader d'abord reconnu en fonction de valeurs traditionnelles, réelles ou transposées. (6)

- (1) Tract de l'UPRONA du 12 octobre 1960, cité par M. Lechat
- (2) Extrait du même tract : "Les traîtres..., ce sont les blancs, ces hôtes qui ressemblent à tout ce que nous ignorons; parmi eux il y a la malhonnêteté. Ils ont fait leur possible pour déchirer le Burundi; où pourront-ils trouver le fil pour recoudre notre pays... Le Gouvernement belge est ennemi de la population parce qu'il se fait complice des meurtriers..." Notons que par ailleurs l'UPRONA affirme sa confiance dans les Européens s'ils ne font pas de politique.
- (3) Ainsi en se défendant contre l'exclusion du Prince Rwagasore de la vie politique : "En ce qui concerne les princes de sang du Burundi, qu'ils soient fils, frères, cousins ou oncles du Mwami, personne parmi eux n'est Mwami et personne parmi eux ne connaît celui qui sera Mwami. C'est pourquoi la coutume les a placés sur le même pied d'égalité en matière d'activité politique dans aucune distinction de leur degré de parenté avec le Mwami." Tract cité par M. Lechat.
- (4) 2e manifeste de l'UPRONA, début 1960, cité par M. Lechat.
- (5) Maurice Duverger : Les partis politiques, 3e éd. Paris 1959 p. 19
- (6) Cf. D.E. Apter : The Gold Coast in Transition, Princeton 1955, et G. Balandier : Le contexte sociologique de la vie politique en Afrique noire, in Revue française de science politique, 1959 p. 607

V. Aux élections communales de novembre 1960, le PDC recueillit 32 % des sièges de conseillers communaux, l'UPRONA 19 %, le Parti Démocrate Rural 17 %, le Parti du Peuple (de tendance "petit peuple") 8 % et tous les autres partis moins de 5 %. Le Front commun (PDC et alliés) totalisait 74 % des sièges.

Un colloque réunit les six plus grands partis pour fixer l'organisation des élections nationales et les structures de l'autonomie interne. Les institutions intérimaires furent en principe boycottées par l'UPRONA.

Les élections nationales de septembre 1961, sous le contrôle de l'ONU, donnèrent des résultats fort différents. Le Prince Rwagasore dont la résidence surveillée avait pris fin, fit campagne pour l'UPRONA, sans toutefois se présenter lui-même aux suffrages des électeurs. L'UPRONA recueillit 80% des suffrages et 36 sièges de députés, alors que le Front commun devait se contenter de 17 % et de 6 sièges. Le détail du scrutin montre que dans la plupart des circonscriptions la victoire du candidat de l'UPRONA est nette. (1)

Le Prince Rwagasore devint Premier ministre et forma un gouvernement UPRONA. Il était assassiné deux semaines plus tard par les leaders du PDC qui furent pendus après un procès recommencé lorsque le Burundi devint indépendant le 1er juillet 1962.

Durant la législature qui prit fin en mars 1965, soit en quarante mois, six gouvernements UPRONA se sont succédés (Gouvernements Rwagasore, Muhirwa, Ngendandumwe, Nyamoya, Ngendandumwe, Kamina). Cette instabilité, qui peut de prime abord paraître curieuse lorsqu'un parti dispose d'une majorité si large, est la conséquence directe de la disparition du Prince Rwagasore et de l'ambiguïté du pouvoir que nous avons déjà soulignée.

VI. Grand vainqueur, l'UPRONA s'affirme le lien entre le passé et l'avenir, sous l'autorité du Mwami, et tend la main aux adversaires pour autant qu'ils n'aient pas semé le trouble : "L'UPRONA a défendu la tradition, l'autorité du Mwami, la nécessité de la discipline et du maintien de l'ordre, le respect des étrangers et de leurs droits, la nécessité du travail, mais aussi la volonté de rénover le Burundi... Le peuple murundi.. a voté à 90 % en faveur de ceux qui lui promettaient l'ordre, l'autorité, la discipline et contre ceux qui cachaient sous des mots vagues et flatteurs un simple désir de domination personnelle, une menace d'anarchie et de distinction (ethnique). Jusque dans son choix de 10 % de représentants de l'opposition; le peuple a discerné les meilleurs et désavoué les auteurs de troubles."(2) Cette volonté d'apaisement participe de la vocation de l'UPRONA à rassembler tout le peuple sous le drapeau de la tradition nationale renouée : "J'exhorte surtout les partisans et amis de l'UPRONA à se montrer dignes de la victoire du Parti. Les militants actifs doivent agrandir le cercle de nos amis, tendre loyalement et cordialement la main aux adversaires d'hier et non étaler de l'orgueil et de l'insolence."(3)

La vocation de parti unique - en fait au moins - allait être clairement affirmée lors des fêtes célébrant l'indépendance nationale : "L'unité de vue doit être effective, sans condition, sans réserve et définitive. Les coeurs de tous les Burundi doivent battre à l'unisson. Le but doit être Un et Unique : Unité et Progrès... Notre idéologie politique est en fonc-

(1) Rudipresse no. 242 et 243 des 23 et 30 septembre 1961

(2) P. Ngendandumwe, alors vice-premier ministre : conférence donnée à l'association Lovania le 9 janvier 1962, in Infor-Burundi (Bulletin hebdomadaire d'information de l'Office national de presse du Burundi) no. 2

(3) Z. Niyenzi, alors commissaire à la Défense nationale : Message à l'armée, in Infor-Burundi no. 25 du 25 juin 1962.

tion de cette idée d'effort dans le redressement national. L'idée de base de notre idéologie politique s'exprime dans ces deux mots : démocratie et coopératives... Le Parti doit être structuré; du haut en bas la consigne ou l'ordre doit passer comme une eau dans son canal." (1)

Lors des campagnes de mobilisation des masses déclenchées par le gouvernement pour redresser une situation économique toujours délicate, les slogans s'articulent autour de deux idées fortes : "La Paix et le Pain", c'est-à-dire la concorde nationale indispensable à l'effort que les paysans doivent fournir pour entretenir leurs caféiers, pour lutter contre l'érosion... Mais cette concorde toujours souhaitée ne règne pas au sein de l'UPRONA : le parti uni autour de la personne du Prince Rwagasore à l'approche de l'indépendance et dans les premières luttes politiques, a perdu son leader au moment où la mise en place de nouvelles institutions rendait sa présence tout particulièrement nécessaire. En effet, le rôle du Mwami l'empêchait d'être le ferment unificateur au niveau de l'appareil politique et de la mobilisation, du quadrillage des masses. Par contre, une personne jouissant d'une situation aussi privilégiée que celle du Prince Rwagasore était à même de capter l'attachement populaire indirect aux nouvelles institutions par l'attachement direct à sa personne (2). Cette position le privilégiait alors vis-à-vis de tous les autres politiciens et lui permettait ainsi d'empêcher plus facilement leurs luttes intestines. Après sa mort, le parti s'est assez rapidement désagrégé, laissant place aux politiques personnelles et à l'instabilité gouvernementale. Les gouvernements se sont succédés sans toujours se ressembler dans les déclarations et dans l'action; et pourtant tous les ministres étaient membres de l'UPRONA. Le Président de l'Assemblée nationale le constatait : "Cette instabilité était due à la division... Outre cette division, il faut remarquer aussi que le parti vainqueur n'a pas reçu la place qui lui revenait dans la direction des affaires publiques. Chaque détenteur d'un poste dans la gestion des affaires publiques s'est senti indépendant et le manque de collaboration est né de la faiblesse du parti qui n'a pas joué son rôle d'organe suprême du pouvoir et la division en a été la conséquence." (3) Et cela, malgré le "culte" rendu à la mémoire du Prince Rwagasore : il était devenu la source de toute pensée politique et chaque politicien invoquait son nom et son enseignement.

Cette division est allée grandissante, prenant de plus en plus une coloration ethnique. Dans un sursaut d'unité nationale, l'UPRONA s'est réuni en conférence de réconciliation en septembre 1964 : "La conférence a aboli les dénominations dépourvues de sens, à savoir celle de Monrovia et celle de Casablanca (4). Il était en effet très dangereux et contraire à l'esprit de l'UPRONA de garder ces terminologies qui, au fond, ne cachaient qu'un venin dans son sein, celui d'une discrimination raciale." (5) Cette unité retrouvée paraît ne pas avoir atteint chacun, malgré maintes bonnes volontés. Les péripéties de la chute du Gouvernement Nyangoya (décembre 1964-janvier 1965) et l'assassinat du nouveau Premier ministre P. Ngendandumwe (janvier 1965) porte G. Nyangona à la conclusion que : "Ce parti gagnant devint le responsable privilégié du présent et de l'avenir de la Nation

- (1) P. Ngendandumwe : discours aux fêtes de l'indépendance, in Infor-Burundi no. 39 du 10 octobre 1962
- (2) Certains observateurs pensent même que cet attachement à la personne de Rwagasore aurait pu l'inciter à confisquer en sa faveur le prestige et le pouvoir royal, et à donner ainsi une solution à l'ambiguïté du pouvoir.
- (3) Th. Siryuyumunsi : discours à la rentrée des vacances parlementaires, in Infor-Burundi no. 128 du 14 novembre 1964
- (4) Ces termes sont empruntés aux deux grandes conférences africaines tenues à Monrovia et à Casablanca et aux deux groupes qui en sont résultés. Mais rapidement, il s'est agi de concepts propres au Burundi, assez vagues et sans rapport direct avec leur origine. En majorité, les Hutu étaient Monrovia et les Tutsi Casablanca; il serait toutefois très difficile de préciser la réalité de ces appellations.
- (5) J. Banina ; Premier ministre et président de l'UPRONA : déclaration radiodiffusée, Infor-Burundi no. 141 du 13 février 1965.

entière. En pratique, ce fut un système de parti unique. Et l'UPRONA, comme tout organe vivant, ne fut pas immunisé contre toutes les déformations. Pis encore, il confisque le pouvoir du peuple au profit d'une minorité. Aujourd'hui, c'est un rassemblement d'une foule de tendances devenues hostiles et un groupement de multiples intérêts devenus irréconciliables."(1)

VII. Si l'UPRONA a toujours manifesté son loyalisme envers le roi (2) - à l'exception de quelques cercles - le roi ne s'est jamais reconnu dans un parti, celui-ci fut-il quasi unique. "Jamais je n'ai envoyé un parti parler en mon nom, jamais je n'ai exclu ou désapprouvé un parti politique. mais, le parti qui parlerait de manière à semer des troubles, celui-là serait alors pour moi un mauvais parti. Je suis du parti de tous les Burundi. Vous êtes tous mes enfants, aucun parti ne peut donc se réclamer devant moi exclusivement."(3) "Vous êtes tous libres de penser, de croire et d'exprimer ce que vous estimez juste à condition de reconnaître cette même liberté aux autres."(4)

Mais le roi reste la source du pouvoir, en ce sens qu'il est responsable de la bonne marche des institutions et du bien-être du peuple. Si le gouvernement faillit à sa tâche, le roi lui retire le pouvoir : "L'ordre doit régner, et parce que je le représente légitimement et que je suis et reste à la fois le bouclier et le depositaire de la Constitution, j'ai décidé de prendre, dans le cadre de la plus stricte légalité, les décisions énergiques qui s'imposaient pour assurer la liberté, la légalité, la justice..."(4) Ainsi un "domaine réserve" se crée petit à petit : lorsque le roi juge qu'un secteur de l'administration doit être dépolitisé pour assurer sa bonne marche, il établit un Secrétariat d'Etat qui est subordonné non pas à l'autorité du gouvernement, mais directement à celle du Chef de l'Etat. Il en est ainsi devenu de l'armée, de la gendarmerie, de la justice, du plan et de l'assistance technique. Cette façon de faire ne manque pas de causer des tensions entre le gouvernement qui obtient la confiance et du roi, et de l'Assemblée, et le roi qui incarne aux yeux de la population la seule légitimité réelle. Cette dualité de la légitimité - incarnée traditionnellement par le Roi, et modernement par l'Assemblée et le Roi - n'est pas encore ressentie dans les masses rurales : ainsi, le Roi ayant fait arrêter (janvier 1965) un député sous l'inculpation de complot, les habitants de la circonscription rurale de ce député ont réagi en disant que ce député n'avait que ce qu'il méritait, car en trahissant la confiance du Roi, il avait trahi la confiance de ses électeurs. Et même plus, alors que la plupart des autres personnes arrêtées à l'occasion de la même affaire ont été relâchées ou mises en liberté provisoire, ce député et quelques autres qui avaient été arrêtés sur l'ordre du Roi, sont maintenus en détention préventive adoucie.

Le Roi maintient ainsi les conditions du libre jeu démocratique. Et à la base de celui-ci l'égalité des citoyens, en particulier devant la loi : "Je ne veux plus entendre parler de Twa, Ganwa, Hutu ou Tutsi. Il n'y a pas

- (1) G. Nyangoma, alors directeur général remplaçant le Premier ministre empêché : discours du 3e anniversaire de l'indépendance, in Infor-Burundi no. 163 du 3 juillet 1965
- (2) P. Ngonzandunwe, Premier ministre, terminait ainsi sa dernière allocution avant son assassinat : "Que le Mwami soit toujours le guide du peuple du Burundi et qu'il sache que tous les Burundi, toutes les Burundikazi le suivent, le suivront toujours et qu'avec son gouvernement le pays est assuré de la prospérité et du bonheur." Infor-Burundi no. 140 du 25 janvier 1965
- (3,4) Discours du Roi. Rudipresse no. 242 du 23 septembre 1961, et Infor-Burundi no. 144 du 13 mars 1965.

plusieurs races au Burundi. Vous êtes tous citoyens d'un même pays, vous êtes tous Burundi. La valeur d'un homme ne se juge pas à la forme du nez ou à la race dont il est issu, mais à sa valeur personnelle, aux services rendus au pays."(1) Reconnaisant la dynamique des changements sociaux, il veille à ce que les institutions y soient adaptées : "Dans le passé, tous les chefs et sous-chefs cumulaient les pouvoirs administratifs et judiciaires. Ce système est dépassé, la démocratisation des institutions exige la séparation des deux pouvoirs."(1) Et que leur fonctionnement n'en soit pas faussé : "Je fais savoir une fois pour toutes à tous les juges depuis le plus petit jusqu'au plus haut échelon que le pouvoir judiciaire appartient au Roi et que tous les jugements sont rendus au nom du Roi. Tout le monde est égal devant la justice... J'interdis encore une fois pour toutes aux Ministres et à tous les autres politiciens de faire pression ou contrainte sur les juges en faveur de certaines personnes."(2)

Si le Roi donne des conseils, et parfois des ordres aux députés et aux ministres, il entend qu'ils soient suivis d'effets. Ces conseils se font de plus en plus pressants : les divisions politiques ne mènent à rien - "Je ne veux plus entendre parler des étiquettes Casablanca ou Monrovia et le refus systématique de collaboration basé sur ces étiquettes"(3) - alors que les problèmes du développement économique doivent avoir la primauté. Si dans ses premiers discours le Roi se contentait d'insister sur la nécessité de travailler, il sera amené petit à petit à formuler des conseils toujours plus précis jusqu'au jour où, jugeant qu'il prêchait dans le désert, il créera un secrétariat d'Etat au plan et à l'assistance technique.

VIII. Constatant que ses conseils ne causaient pas les effets escomptés et que "le Parlement a donné le spectacle désolant de divergences inspirées non par des oppositions d'idéaux, de principes ou de programmes politiques, mais bien alimentées par des querelles mesquines ou de jalousie, les intrigues, les délations, les calomnies des personnes, les trafics d'influence, voire même le crime, sans considération de l'intérêt supérieur du Pays"(4), le Roi a finalement dissous l'Assemblée nationale et confié la gestion des affaires courantes aux directeurs généraux des ministères, mettant ainsi provisoirement fin à la crise d'autorité consécutive à la division de l'UPRONA. "Toutes les mesures gouvernementales furent prises sur commande. Tantôt la Cour royale, tantôt l'Assemblée législative, tantôt le Gouvernement et toujours des individus prirent des mesures engageant le présent et l'avenir de tout un peuple."(5)

Toutes les garanties en vue d'élections libres furent prises par la Commission royale de législation électorale (commission extra-parlementaire). Le nombre des députés a été réduit de 62 à 33, alors qu'un Sénat, élu indirectement et en partie coopté et désigné, de 16 membres était institué. Le climat de liberté, la multitude des candidats (plus de 400 pour 33 sièges), la reconstitution du Parti du Peuple (PP) dont le programme et l'organisation rudimentaire sont surtout l'expression du sentiment de frustration du "petit peuple", le grand nombre de listes individuelles, sont les conséquences du vide politique et idéologique au niveau des partis. Les conditions sont fort différentes des précédentes élections : aucun programme, aucune perspectives nationales, aucun slogan national ne sont

(1)-(4) Discours du Roi. Infor-Burundi no. 8 du 24 février 1962, no. 10 du 10 mars 1962, no. 128 du 14 novembre 1964, no. 144 du 13 mars 1965

(5) G. Nyangoma : discours du 3e anniversaire de l'indépendance. Infor-Burundi no. 153 du 3 juillet 1965.

proposés aux citoyens. L'UPRONA reste divisée et présente jusqu'à cinq listes par circonscription, sans que plus personne ne sache qui a véritablement droit à l'étiquette de l'UPRONA. Et ce n'est pas la commission électorale qui s'est acquittée avec grands scrupules de son rôle technique, qui pouvait proposer des mots d'ordre nationaux.

Cet appel au peuple ne pouvait créer une unité autour d'un programme, car le peuple ne saurait spontanément élaborer un programme ! Il s'est contenté de manifester sa désapprobation à l'égard de l'immense majorité des députés sortant de charge : huit seulement ont été réélus ; et le Parti du Peuple envoya dix députés néophytes au Parlement (alors qu'il ne présentait de listes que dans 23 circonscriptions sur 33). Les personnalités se réclamant de l'UPRONA restent néanmoins mieux connues que celles du PP : les députés UPRONA ont, en moyenne, recueilli 48 % des suffrages sur leurs têtes, alors que les élus du PP n'atteignaient que 33 % dans les circonscriptions où ils ont été victorieux. Les Ganwa qui se présentaient sur liste UPRONA et qui ont été élus, recueillent en moyenne 49 % des voix de leur circonscription (soit la même proportion que l'ensemble des élus du parti) - ce qui tendrait à prouver que le prestige attaché aux anciennes hiérarchies n'est plus très fortement ressenti dans les masses paysannes. Les quelques députés réélus par contre semblent affirmer leur prestige personnel, puisqu'ils totalisent en moyenne 54 % des voix de leur circonscription.

Ces élections montrent la vigueur des dynamismes sociaux à l'intérieur de la population rurale du Burundi. L'analyse faite par G. Nyangoma en rend compte : "La dynamique globale de l'action sociale telle qu'elle se manifesta au lendemain des élections législatives de mai 1965, agit en faveur d'une ouverture démocratique du changement. La majorité écrasante de la population paysanne vivant dans des conditions extrêmes de misère, pousse vers la transformation radicale de la société traditionnelle et appuie toutes les mesures que les éléments actifs du peuple adoptent dans ce sens. C'est dans l'interaction de ces conditions objectives que se situe l'action donnant un coup d'arrêt aux forces hostiles au progrès et à la démocratie. Il faut rappeler que la nature du pouvoir démocratique est d'être le défenseur des intérêts des couches laborieuses. Il ne peut, en conséquence, ne pas se heurter aux couches privilégiées."(1)

La répartition des sièges entre partis à l'Assemblée et au Sénat est une simple indication électorale ; elle n'implique pas une divergence de programme, ni d'ailleurs une convergence, puisque les élections se sont faites surtout sur des personnes se réclamant de sigles au contenu diffus et variable. Cependant, en confirmation de l'analyse citée ci-dessus, il faut remarquer que bon nombre de députés sont de simples gens très proches de leurs électeurs et que les Hutu (de l'UPRONA et du PP) disposent de 23 sièges à l'Assemblée. G. Nyangoma, poursuivant son analyse, insiste sur le rôle nécessaire du parti dans la direction de la société : "Ce moteur, c'est le parti, un parti conscient des intérêts des travailleurs, un parti déterminé à donner sa signification réelle à toutes les initiatives populaires... Aujourd'hui, il est possible d'avoir un cadre, un corps, voire même un parti homogène tirant sa force d'une base essentiellement paysanne... Mais, pour acquiescer les capacités de mobiliser, guider, orienter le peuple, ce parti ne saurait se confiner dans le cloisonnement. Bien au contraire, d'autres couches sociales, sans jouer un rôle dirigeant, constituent un facteur non négligeable dans la recherche de l'adhésion du peuple à sa politique."(1)

(1) Discours du 3e anniversaire de l'indépendance. Infor-Burundi no. 153
du 3 juillet 1965

Sous les généralités de ce discours, un esprit entièrement nouveau se profile : la primauté, la véritable légitimité du pouvoir appartient aux masses paysannes qui ont choisi leurs députés. Les dynamismes sociaux ont été si puissants qu'ils ont fait définitivement sauter - du moins l'orateur le pense - les cadres traditionnels. Dans la restructuration de la société qui doit découler de cette brusque accélération dans la prise de conscience des masses populaires, le parti, un nouveau parti à vocation de parti se heurtera nécessairement aux couches privilégiées (et peut-on entendre par là autre chose que le sommet de la hiérarchie sociale et politique, c'est-à-dire la famille royale et certains Tutsi ?). Il acceptera en son sein ceux qui, appartenant à d'autres couches sociales (et peut-on entendre par là autre chose que les Tutsi ?), voudront bien collaborer mais ne diriger.

Ce discours fait d'une crise latente, une crise ouverte. Fort de la nouvelle répartition ethnique à l'Assemblée nationale, G. Nyangoma en tire la conclusion que les masses paysannes (c'est-à-dire les masses Hutu) veulent la transformation radicale de la société traditionnelle. Même s'il poussait trop loin son analyse, "il cristallisait les aspirations de nombreux leaders Hutu, désireux d'accéder eux aussi aux postes de responsabilité et lançait en quelque sorte ses amis à la conquête de ce pouvoir détenu en grande partie par les Tutsi." (1)

IX. Mais, dans le même temps, le Roi a tenu à affirmer avec force la nécessité d'adapter la constitution du Royaume "habilement calquée, sans examen approfondi, sur une constitution vétuste importée d'Europe" et qui "ne peut être viable parce qu'elle ignore les traditions ancestrales propres au Burundi" (2) - et que'elle fait du Parlement le dépositaire de la légitimité du pouvoir. Cette réforme projetée doit assurer l'égalité et la liberté de tous les habitants sans distinction. Il semble bien que c'est sur l'organisation du pouvoir et des pouvoirs délégués qu'elle doit porter pour que "souple et démocratique" la constitution soit "à la portée des Burundi qui ont toujours connu, appréciée et respecté l'autorité suprême de leurs bami (rois) sous l'égide de l'Imana." (2) Il ne s'agit pas de "ressusciter certaines coutumes désuètes et dépassées" (2) mais au contraire d'accepter les notions modernes, non comme des corps étrangers, mais en les médiatisant à la lumière de la tradition. Et dans cette perspective, le rôle de la monarchie est grand, car elle est "le trait d'union qui relie le présent au passé. Elle représente l'écran sur lequel se projette l'avenir de la nation." (3)

Face à l'accélération des changements sociaux et aux difficultés que sa vitesse entraîne, il est nécessaire d'affirmer la pérennité du cadre: la monarchie. Mais celle-ci ne doit pas être totalement vidée de son contenu : "Vous ne comprenez certainement pas, pas plus que moi d'ailleurs, que par une subtilité du terme qui affirme que "le roi règne mais ne gouverne pas" on puisse heurter de front des traditions solidement ancrées dans vos coeurs et vos esprits. Autrement dit votre Mwami ne serait qu'un simple symbole n'ayant rien à dire, mais au nom duquel le feu vert serait donné pour permettre l'usurpation des pouvoirs dans tous les domaines de la vie publique." (2)

(1) Hebdomadaire "Jeune Afrique", 256 du 21 novembre 1965

(2) Message du Roi au peuple burundis. Infor-Burundi no. 115 du juillet 1965 - La Constitution du Burundi est une copie assez fidèle de

(3) R. Lemarchand : cit. p. 355

La source première du pouvoir reste donc le Roi, et plus encore la fonction royale que la personne du Roi; et par conséquent la continuité dynastique est proclamée : le Roi prépare son fils à lui succéder un jour.

Si la tradition, dans ce qu'elle conserve d'actuel, s'oppose à un changement de légitimité, elle impose en contre-partie le devoir de protection de celui qui dispose du pouvoir à l'égard du peuple : "Je refuse de souscrire à pareil subterfuge (être un simple symbole) qui n'enlèverait tout contrôle, toute autorité et toute possibilité de vous protéger dans vos personnes et dans vos biens."(1) Cette légitimité trouve ainsi sa justification, non dans le monde rationnel, mais dans la volonté d'Inana (la force suprême, le principe fécondant mâle, qui dispose de tout et ordonne tout; avant d'être devenu le Dieu des chrétiens dans la langue du Burundi); et elle ne reste actuelle que dans la mesure où, à travers le jeu d'institutions démocratiques modernes médiatisées et au besoin contre elles si elles défontent, elle assure le jeu de la dynamique des changements sociaux, c'est-à-dire le progrès et la démocratie au niveau du peuple tout entier.

X. Les faits politiques de l'été 1965 vont montrer que l'ambiguïté de la légitimité du pouvoir a fait place à une situation de crise, telle qu'elle apparaît en pleine lumière dans les deux discours ci-dessus. L'Assemblée nationale commence par refuser de procéder aux votes nécessaires à l'élection du Sénat, et finalement ne le fait que sur l'injonction impérative du Roi. L'attitude de l'Assemblée nationale doit être certainement interprétée par la crainte des députés de voir réapparaître dans la vie politique du pays en tant que sénateurs certains politiciens écartés par les élections.

Le Premier ministre, M. Biha, n'est désigné que plusieurs mois après les élections et éprouve quelques difficultés à choisir ses collaborateurs dans l'équipe ministérielle. Il semble que les Chambres aient préféré G. Nyangoma à M. Biha, cousin du Roi, qui, après un bref passage dans la politique au moment de l'autonomie interne du Burundi, n'avait plus joué de rôle politique actif, et qui est l'homme de confiance du Roi, dont il était précédemment le secrétaire privé. Il fallait en effet "un homme qui sache s'imposer et qui soit au-dessus des partis et des ethnies."(2) Le parti UPRONA, quant à lui, aurait préféré M. Siryuyumunsi, président de l'Assemblée dans la première législature. Mais le Roi a passé outre aux vœux de l'Assemblée et des partis, comme il s'est également passé de demander aux Chambres l'investiture du nouveau gouvernement.

Un nouveau conflit surgit entre le Roi et l'Assemblée : celle-ci propose, selon la Constitution, une liste de personnalités parmi lesquelles le Roi choisit les membres du Conseil de la Couronne. Le Roi refuse G. Nyangoma qui était proposé, et désavoue ainsi les vœux que celui-ci avait exprimés lors du 30^e anniversaire de l'indépendance.

(1) Message du Roi au peuple burundis. Infor-Burundi no. 155 du 17 juillet 1965

(2) Hebdomadaire "Jeune Afrique" no. 256 du 21 novembre 1965

La majorité des Chambres a ainsi l'impression que le pouvoir est en train de lui échapper, que le changement apporté par les élections ne se répercutera pas dans la vie politique et dans les structures du pays. La tension s'accroît et les présidents des deux Chambres et les quatre vice-présidents (tous Hutu) adressent au Roi une motion, par laquelle ils annoncent leur volonté de boycotter les prochaines élections communales si le projet de loi sur les communes entre en force. Ce projet, élaboré par une commission extra-parlementaire, prévoit que le nombre des communes est ramené de 181 à 78, que les bourgmestres sont nommés et non plus élus, que les conseillers communaux seront élus en janvier 1966 à la suite d'une procédure électorale simplifiée. Le Roi passe outre à cette menace et promulgue la réorganisation des communes par arrêté-loi.

La tension est à son comble. Dans la nuit du 18 au 19 octobre 1965 un groupe d'officiers Hutu de la Gendarmerie et de l'Armée attaquent le Palais royal. Un commando blesse grièvement le Premier ministre, tandis que le Roi parvient à échapper. Les troupes restées loyales sont rapidement maîtresses de la situation.

XI. Si le principe monarchique a été abandonné par bon nombre de politiciens (1), le peuple, par ses réactions, ne semble pas avoir encore suivi les analyses de ses leaders jusqu'ou ils les ont menées. Il a opéré le choix précédemment décrit lors des élections, mais dans la région de Muramvya (la seule qui se soit soulevée au moment du coup d'Etat), des Hutu attaquaient les Tutsi au nom du Roi (!), et les autres provinces sont restées calmes en ce moment-là.

Cette mise en question de la légitimité traditionnelle s'est accompagnée d'une désintégration sociale que l'évolution propre au Burundi ne laissait pas nécessairement prévoir; au contraire. En effet, "la mort de Pierre Ngendandumwe avait suscité une vive élotion parmi la population Hutu. Il incarnait la conciliation, l'apaisement et sa présence à la tête du gouvernement semblait garantir l'accession progressive aux postes de responsabilités d'éléments Hutu formés et capables. Ses assassins courent encore et les charges retenues contre ceux qui sont en prison préventive ne permettent pas de conclure à leur culpabilité. Mais le mécanisme de la colère raciale a été enclenché. Ceux qui rêvaient d'une république au Burundi ont exploité cette colère et perfectionné le mécanisme." (2)

Le Burundi d'aujourd'hui se trouve ainsi confronté au plus grave problème de son existence moderne : la mise en cause de la légitimité du pouvoir doublée d'une profonde division ethnique.

Au terme de cette brève analyse de la conception des rapports politiques au Burundi et de son évolution, il semble que le seuil fixé par D. Apter (3) soit atteint : L'autocratie modernisatrice peut adapter et ajuster ses institutions sans grandes difficultés jusqu'à ce que le point soit atteint où le principe monarchique même est mis en question; à ce moment, soit la modernisation et le changement sont bloqués, soit le système entier fait place à un principe différent d'autorité, conforme au modèle de mobilisation ou consociationnel.

(1) La liste des politiciens Hutu jugés pour atteinte à la sécurité de l'Etat condamnés à mort et exécutés, est longue. Y figurent : le président du Sénat et président de l'UPRONA, le président de l'Assemblée, les 4 vice-présidents, le président du PP, G. Nyangoma, plusieurs hauts fonctionnaires,...

(2) Hebdomadaire "Jeune Afrique" no. 256 du 21 novembre 1965

(3) D.E. Apter : op.cit. p. 20 ss.

RE-OPENING OF THE CHILD-STUDY CENTRE AT THE MAKERERE INSTITUTE OF EDUCATION

by
Cornish Bowden

The Child Study Centre Nursery School at the Institute of Education, Makerere University College, Kampala, was re-opened on 21st. October, 1965 with an enrolment of 22 children.

For two years prior to this date, the school had been closed. However, with the establishment of the National Institute of Education and plans to conduct in-service courses for teacher training college staff, it was deemed highly desirable for the Nursery School to be re-opened and provide opportunities for child study and research on the spot. This view was supported by the Faculty of Education and the Department of Sociology.

A generous grant from the Carnegie Foundation provided the necessary funds for a teacher's salary and for appropriate equipment.

Informal discussions began in September between the Institute, the Faculty of Education and the Department of Sociology with a view to considering the most desirable structure, philosophy and programme of the projected school. There was general agreement that the school should serve as wide an area as possible within the University, that the needs of the children in this setting should be our central concern. The task of reconciling research projects, student observation and the nursery school programme was considered in detail and provisional agreement was reached on the following points:-

- (a) An initial full enrolment of 20 children;
- (b) A fair distribution of girls and boys;
- (c) Two age groups, namely 3 to 4 years and 4 to 5 years;
- (d) Enrolment from these ethnic groups represented on the Makerere staff;
- (e) Enrolment to be spread over Makerere senior and junior staff;
- (f) Enrolment to include a proportion of children from the Makerere neighbourhood outside the University, but that this be limited to nearby geographical areas;
- (g) Hourly attendance from 8 to 11.30 a.m.;
- (h) Fees proposed being Shs. 20/- per term.

At a subsequent meeting the group considered the following:-

1. Research - projects which might be considered appropriate in connection with the Institute's courses for teachers and training college tutors, the Faculty of Education's B.Ed. and Diploma courses and the Department of Sociology's Research projects. Research projects considered included:-

- (a) Unstructured Observation daily;
- (b) Sociability Patterns;
- (c) Interest span;
- (d) Development of New Behaviour Patterns;
- (e) Ability Assessment;
- (f) Personality Assessment;
- (g) Visual perception;
- (h) Piaget-type studies;
- (i) Learning theories.

2. Criteria of Selection - $\frac{1}{3}$ African, $\frac{1}{3}$ Asian, $\frac{1}{3}$ European - It was proposed that from the standpoint of scientific use there should be -

- (a) An experimental group;
- (b) A control group;
- (c) Twice as many children interviewed as would be enrolled to supply a control group.

3. A Questionnaire Design was set up for parents applying for entrance. The questionnaire form included 82 items designed to make a first exploration of parental attitudes, child-rearing practice, home background, feeding patterns, physical state, size of family, etc.

4. Interview Procedure - There were four interviewers for the initial intake. One spoke Luganda and interviewed those parents who spoke no English. Approximately 40 minutes was allowed for each interview. Parents were asked to bring their children with them. Interviewers were instructed to outline our philosophy, namely, that the Nursery School setting would provide opportunities for a rich and varied

programme of play, creative activities with music, paint, building blocks, water, etc.

Development of skills, language and observation would be encouraged through guidance in the use of simple tools, observation in natural science, and through conversation. No formal schooling nor teaching of reading and number would be offered, in the belief that a firm foundation for future learning is laid on a comprehensive nursery school experience.

Parents were asked whether they would be willing to attend meetings, to be interviewed in their homes, and to come to the nursery school to observe their children in the one-way vision observation room.

5. Selection Procedure - The final selection from the first 35 interviews was carried out anonymously. Each child was numbered and classified according to the categories stated, i.e. age, sex, ethnic origin, father's occupational status. There was a pre-determined number of children in each category.

Final Outcome

Twenty-two children were enrolled, - 14 African, 6 European and 2 Asian. Ten children were admitted on Thursday, 21st October and the remainder on Monday, 25th October, 1965.

6. Language - The language of communication in the nursery school is English. A few of the African and Asian children understood a little English, but for the most part they are Luganda-speaking. Both the teacher and her assistant speak English to the children except on occasion when a child is in trouble or distress. The conversation held with the children at times of group activities, e.g. story telling and music, are in English. No means of measuring language comprehension had been devised at the time of the opening of the school so any estimate of the speed of comprehension and facility in communication by the non-English-speaking group must be highly speculative. There is no doubt that at the end of the first six weeks the children were communicating freely with each other and with adults.

7. Staffing - In view of the projected use of the school and its constant use by students and observers, the appointment of suitable staff was of major importance. The Committee set to find a Ugandan teacher able to work in a research setting and be under constant scrutiny, and one who had nursery school specialist training as well as primary training, with experience in teaching in Uganda and able to speak Luganda.

The position was advertised in the Argus on September, 6th, with an immediate and gratifying response. At the time of the interviews, a group of Uganda Primary teachers returned from a two-year up-grading training in Australia. Two of these teachers had specialized in pre-school education. Of these, one applied for the post and was appointed. The assistant was recruited from Sanyu Babies Home. She is completing her two-year training in preparation for the National Nursery Examination Board Examination in June. Two short-listed applicants for the position of nursery school teacher have become Research Assistants in the Makerere Department of Sociology and have carried out the initial research study, reported at the end of this paper.

THE RESEARCH

The initial phase of the research consisted of unstructured behavioural observations, supplemented on two occasions by tape recordings of the complete four-hour sessions during the first six days of the nursery school. Observations were made from an elevated adjoining room equipped with one-way vision screens by two observers trained in the technique at the University of Maryland. One of the observers, Miss K. Paul, concentrated on the boys, while the other, Mrs. Adrienne Kattcr, recorded the activities of the girls. The observers were instructed to avoid interpretive comments on their observations and to restrict the content of their notes to what the children said or did. Recording the content of conversation was an obvious problem since the

~~majority of children speaks~~ Luganda and neither of the observers understands this language. However the import of this problem is reduced somewhat since (i) a strikingly small amount of verbal interaction by the African children actually took place during these initial six days; (ii) when they did talk the children's verbalizations were accompanied by other behaviour which partially explained their verbalisation; and (iii) tape recordings of two full sessions were available and would be played back to a Luganda speaking assistant if one wished to determine the conversation content. Still, for this set of observations, little attention could be paid to verbal behaviour, except to note its presence or absence. The school opened on Thursday, 21st October at 8 a.m. And approximately half of the total group admitted were invited to begin school on that day. Those present on that first day included two African boys, Douglas Serubugo and David Lutwama, and 5 African girls - Joyce Kamara, Irene Nyamisana, Alice Kabusingye, Sara Mubunya and Shiela Kidza plus two English-speaking children of English parentage - Helen McGregor and David Hoyle. (For reasons that will be made clear when we return to the recorded observations of the first day, they deal to a disproportionate extent with the behaviour of the two English children, in spite of the fact that it is the behaviour of the African children which constitutes our concern in this research).

This initial group of 9 children attended the school session on the next day - Friday - and were not joined by the second half of the group until the following Monday. On that day they were joined by the five African boys, Michael Mukasa, Aggrey Mugisha, Michael Banigana, Stephen Sonko and Robert Kandali, and by two African girls, Robina Kintu, and Amina Munyango plus one Indian boy Slinder and one English boy - Andrew Bradley and a set of English girl twins, Kate and Sarah Hutchinson.

During this initial six-day period changes in composition of the total group occurred. One African boy, Joseph, joined on the fourth day. For purposes of this phase of the study the children on whom we are commenting include seven African girls (Joyce, Irene, Alice, Sarah, Shiela, Robin and Amina), and eight African boys (Douglas, David, L., Michael M, Robert Aggrey, Michael, B, Stephen and David, K).

For most of these children, opportunities to observe them spanned four 4-hour sessions and covered as many as six sessions in some cases.

With regard to the notes made by the two observers from the observation room, it should be noted that these contain reports of the behaviour of all the children present, including the non-Africans. However, subsequent distillations of the original notes were made by the observers with the non-African children treated, in so far as possible, only as social stimuli for the African children. These distillations were made independently by the two observers from their own notes, and not until six sessions had been observed.

The distillations were prepared in several forms. In one, efforts were made to note each individual child's behaviour during every fifteen minute sequence of his time at school. To facilitate the ordering of the data, sheets were prepared in tabular form, with each sheet providing the framework for a child by time unit matrix. Entries into each cell were made by the observers from their own initial sets of notes. For a variety of reasons, notably the inability of the observers to note every child's behaviour during every 15-minute period, the resultant matrices contain many empty cells, but for most children, at least some behavioural trends can be discovered, and a degree of confidence invested in them, since a number of entries is available.

The observers also prepared several paragraphs describing the general activities of each day, these paragraphs constituting summaries of the initial notes. As these efforts were made to describe the overall pattern of events without attending to individual children.

Finally, each observer wrote a short essay in which she summarized changes in mood and atmosphere which appeared to her to have taken place over the 6-day period.

Armed with these various distillations the initial sets of notes made in the observation room and two tape recordings (from

(from.....1 and 3) I have prepared the following report of events. This report is obviously very subjective and subject to errors of observation, of recording and of interpretation. But, in terms of the over-all program of research, it is intended to serve primarily as a source of hypotheses to be subjected to vigorous testing. As a source of hypotheses it is extremely provocative.

ON THE CONCEPT OF URBANIZATION¹

by
Josef Gugler

"Urbanization no longer denotes merely the process by which persons are attracted to a place called the city and incorporated into its system of life. It refers also to that cumulative accentuation of the characteristics distinctive of the mode of life which is associated with the growth of cities, and finally to the changes in the direction of modes of life recognized as urban which are apparent among people, wherever they may be, who have come under the spell of the influences which the city exerts by virtue of the power of its institutions and personalities operating through the means of communication and transportation." (Wirth 1938)

I have argued elsewhere (Gugler 1965) that a large proportion of Africa's urban population live in a dual system: they are not only part of the town² they live in, but at the same time they continue to belong to the village they have come from. Here I propose to discuss how to assess the relative strength of the urban and the rural pole for a given individual. I suggest that four dimensions of urbanization have to be considered separately: an individual's residence, his economic support, his social field, and his culture. I further discuss for each dimension analytical approaches that can be used to measure relative degrees of urbanization. We should thus be able to compare the degree of urbanization of different individuals and of the populations of different communities, and to assess changes over time, that is study the process of urbanization, be it of a given individual, or of a community with its changing population.

1 Residence

Certainly the sheer physical presence of a man in the urban setting is of sociological importance. As Max Gluckman (1945: 12) put it twenty years ago:

"... in a sense every African is detribalised as soon as he leaves his tribal area, even though he continues to be acted on by tribal influences: he lives in different kinds of groupings; earns his livelihood in a different way, comes under different authorities."

¹This paper is part of the East African Institute of Social Research Conference Papers January 1966. It was first stimulated, and remains much indebted to, an article by Philip Mayer (1962): "Migrancy and the study of Africans in town".

²Though the literature on urbanism is consistently concerned with "cities", I use throughout this paper the term "town", because most urban communities studied in Africa are not cities in common parlance, while still satisfying the sociologist's criteria for urban-ness by their size, density and heterogeneity.

This is the only aspect of urbanization for which quantification has been achieved. Godfrey Wilson (1941) was the first to develop a measure of relative length of urban as against rural residence. He distinguished between peasant visitors, migrant labourers, temporarily urbanized and permanently urbanized, defining these categories according to the proportion of his time an individual has spent in town since first leaving his rural home area,³ and proceeded to calculate the percentage of the African population of Broken Hill that fell into each of these four categories. Wilson (1941: 46f) was thus able to show that the image of the African worker as a migrant labourer was outdated: 70% in his sample, though born and bred in the country, had spent over two thirds of their time in town since first leaving their villages, that is were temporarily urbanized according to his definition.

Clyde Mitchell (1956) developed from this approach an "index of stabilisation":⁴

$$\frac{\text{years in town since turned 15}}{\text{years lived since turned 15}} \times 100.$$

This index suffers however from considerable disabilities. It does not differentiate between a man who has come to town late in his life, but then stayed continuously, and another man who came earlier, but interrupted his urban residence by spells in his area of origin. It further fails to differentiate between people who are born in town, who have come to town in young age, or only at age 15. Finally this index gives the proportion of time spent in town and therefore not the length of urban residence. Mitchell (1956: 706f) recognized this last difficulty and suggested that the only way in which effective comparisons between populations can be made is by comparing the index of stabilisation in various age groups. Merran McCulloch (1956:72f, 56) in her study of Livingstone gives such a breakdown but comments only very briefly.

Mitchell's (1956: 707f) major contribution to this problem has been an attitude scale for answers as to intentions of future residence in town. Eight categories of responses on this scale were classified into typical labour migrant responses (they are in town for a specific purpose and have no intention of staying longer than necessary), typical attitudes of temporary stabilization (they intend to leave town some day, when is quite uncertain, not however in the immediate future), and responses of permanent stabilization (they have no intentions of returning home). We may expect certain divergences between the category a man comes under ex post according to the relative length of his urban residence since the age of fifteen, and the category he falls into when expressing ex ante his

³ McCulloch (1956: 73) is the only author to explain how she had dealt with the problem of visits home: she excluded visits of 6 months duration or more from time in town.

⁴ Reader (1961: 158f) uses the term "stabilization" in a different sense, measuring stabilization by the total period spent in urban areas by a person since the age of 15 years.

intentions as to future urban residence. The lack of fit comes nevertheless as a surprise in the following table of data from Mitchell (1956: 708):

Table 1 1720 adult men in Luanshya (1951) and Broken Hill (1953)

proportion of life spent in town since age 15	intention of future urban residence,			total ⁵
	labour migrants	temporarily stabilized	permanently stabilized	
1%-33% (peasant visitors ⁶)	24%	13%	0%	38%
34-66% (migrant labourers ⁶)	17%	14%	1%	32%
67-99% (temporarily stabilized ⁶)	9%	7%	3%	19%
whole life since age 15 ⁷ (permanently stabilized ⁶)	3%	4%	2%	11%
total ⁵	55%	39%	7%	100%

Mitchell (1956: 708) has only commented on the high proportion of permanently urbanized ex post who appeared as labour migrants ex ante arguing that many Africans accept the proposition that their rightful home is in some rural area. The same type of information given without any comment by McCulloch (1956: 74) leads to similarly unsatisfying results. Mitchell (1956 *passim*) has been particularly interested in obtaining a predictive measure of future urban residence. We must conclude that the results from the ex post and the ex ante approach show considerable divergence and that without a follow-up study we do not know which is the better predictive measure.

2 Economic Support

Most sociologists and social anthropologists dealing with urbanization tend to relegate the economic aspects, if they consider them at all, to a discussion of causes. I suggest that economic support be considered a significant dimension of urbanization independent of residence, social field and culture. A similar position has been taken by Walter Elkan and Lloyd Fallers in a discussion of labour mobility:

"Wage labourers, or proletarians, are a sociological rather than an economic category. They are people whose lives and livelihoods closely depend on wages, generally from birth to death. They may have other sources of income but these are subsidiary or supplementary to wages." (Elkan and Fallers 1960: 238)

For our purpose we may say that a man is more or less urbanized according to the degree to which he is dependent on urban as distinct from rural income. Elkan (1960: 135) has stressed that farm income is a part of the family income no less

⁵Individual figures do not necessarily add to totals because of rounding.

⁶Mitchell (1954: 167) adopted these terms, but there is no reference to them in his later work.

⁷Mitchell says only "whole life", but his entire approach and data given in an earlier table (1956: 706) seem to justify this amendment.

or

"Typically' urban, in this model, is an epithet for social systems such as trade unions (Gluckman 1960: 58): their urban-ness is not just that they do exist in town, but that they could not well exist anywhere else; they are social phenomena of a type intrinsically associated with urban areas." (Mayer 1962: 585)

Certainly, trade unions cannot be called typically urban associations. Not only is agricultural labour often organized in trade unions, but many towns are without trade unions. Without referring to preindustrial towns we may take Mayer's (1961) study of East London in which he stresses repeatedly that this form of association - at least as far as Africans are concerned - is ruled out in South Africa, as indeed in any totalitarian state. What trade unions really represent is industrial culture as practised in parts of the Western World.

There is a danger here that what is called urban is in fact a residual category covering all that is not traditional. I intend to argue elsewhere that the prime agent of social change in the recent history of Africa has been neither urbanization nor industrialization as such, but Western culture - in only certain of its aspects for that matter. Today the African elites face the challenge of retaining those aspects of Western culture which are necessary correlates of the modernization of the organisational structure that is required if they are to achieve their goal of economic development in a highly competitive world economy and polity.

Here we have to ask what belongs necessarily to urban culture, to the preindustrial town as much as to the industrial city, to a town anywhere in the world, irrespective of the local culture. Wirth (1938) makes this point clearly:

"It is particularly important to call attention to the danger of confusing urbanism with industrialism and modern capitalism. The rise of cities in the modern world is undoubtedly not independent of the emergence of modern power-driven machine technology, mass production, and capitalistic enterprise. But different as the cities of earlier epochs may have been by virtue of their development in a preindustrial and precapitalistic order from the great cities of today, they were, nevertheless, cities."

In this sense most of the criteria of cultural urbanization listed by Mayer (1961: 10) are not urban: recreational opportunities which cannot be experienced in the country: cinemas, dance halls, cafes, beauty contests, daily newspapers; less patriarchal relations of a woman to her husband and to her parents-in-law; dress (significantly rural dress is defined as that which gives its owner away as of the country). The only exception is where Mayer mentions a difference of manner and expression which he finds far easier to feel than to describe: the really urban persons tends to be quicker, to be "smarter", to look in a different way.

Again, the values that Mayer (1961: 11) considers indicate how far various urban patterns have been internalized are - except for the evaluation of town and country ways, and of town and country people - not specifically urban: religious and supernatural beliefs (in as far as he is not concerned with secularization

but with the switch from traditional to Christian religion); views on the proper relations between the generations and the sexes, and on seniority and "respect"; attitudes towards "tribal customs"; aspirations for one's own and one's children's future.

Mayer (1961: 283) rightly stresses that life in town demands more numerous acts of choice than life in the country. Here we come to an element of the cultural dimension of urbanization: we may call the man more urbanized who makes a more individual choice both in the "structural" and the "cultural" sphere. It is in this sense that we can say that an aspect of what is often vaguely called "tribalism", the choice of associates and cultural patterns according to traditional standards, is not urban. A further criterion would be that the urbanized individual meets others in highly segmental roles and that no single group has his full allegiance. A close-knit network, e.g. with fellow-migrants from the same home area, may be in the social field of the town but is an indication of folk culture.

Conclusion

The distinction between four separate dimensions of urbanization: residence, economic support, social field and culture, is here proposed because, though they are interrelated, no necessary relationship can be established between any of them. Two examples will illustrate this point.

It is often assumed that if any change does take place at all when an individual stays in town over a prolonged period, it must be that his social field shifts from the rural to the urban scene. Mayer (1961: 11) in his study of East London found however, that many peasant migrants became more strongly country-rooted, to use his term, as they approached middle age or old age, than they had been during their younger years: the bias had shifted first towards town, and then away again.

In recent years there has been a remarkable drop in labour turnover in Uganda. We may assume that this implies a change to more prolonged and/or more continuous urban residence of those in employment. At the same time a majority appear to have maintained their stake in the rural economy because they cannot obtain adequate compensation for the income and security they would forego by vacating their farm.

As these examples already indicate, the distinction here proposed is not a purely academic exercise. For instance I think that it could be usefully applied to a better understanding of labour productivity. A study of the relationship between these four dimensions of urbanization and labour productivity in different jobs might yield results of theoretical as well as practical interest.

Bibliography

- Elkan, Walter 1960 Migrants and proletarians: Urban labour in the economic development of Uganda. Oxford UP.
- Elkan, Walter; and Fallers, Lloyd A. 1960 The mobility of labor. Pages 238-257 in Moore, Wilbert E.; and Feldman, Arnold S. (editors), Labor commitment and social change in developing areas. New York: Social Science Research Council.
- Gluckman, Max 1945 Seven -year research plan of the Rhodes-Livingstone Institute of Social Studies in British Central Africa. Rhodes-Livingstone Journal 4: 1-32.
- Gluckman, Max 1960 Tribalism in modern British Central Africa. Cahiers d'Etudes Africaines 1: 55-70
- Gugler, Josef 1965 Life in a dual system. East African Institute of Social Research Conference Papers January 1965. Kampala: East African Institute of Social Research. Mimeo.
- McCulloch, Merran 1956 A social survey of the African population of Livingstone. Rhodes-Livingstone Papers 26. Manchester: Manchester UP.
- Mayer, Philip 1961 Townsmen or Tribesmen: Conservation and the process of urbanization in a South African city. Oxford UP.
- Mayer, Philip 1962 Migrancy and the study of Africans in town. American Anthropologist 64: 576-592.
- Mitchell, J. Clyde 1954 African urbanization in Ndola and Luanshya. Rhodes-Livingstone Communication 6. Lusaka: Rhodes-Livingstone Institute. Mimeo.
- Mitchell, J. Clyde 1956 Urbanization, detribalization and stabilization in Southern Africa: A problem of definition and measurement. Pages 693-711 in Social implications of industrialization and urbanization in Africa South of the Sahara. UNESCO.
- Reader, D.H. 1961 The black man's portion: History, demography and living conditions in the native locations of East London Cape Province. Oxford UP.
- Wilson, Godfrey 1941 An essay on the economics of detribalization in Northern Rhodesia: Part I. Rhodes-Livingstone Papers 5. Livingstone: Rhodes-Livingstone Institute.
- Wirth, Louis 1938 Urbanism as a way of life. American Journal of Sociology 44.

BRITISH ADMINISTRATION AND RELIGIOUS LIBERTY IN UGANDA

1890 - 1900.

Holger B. Hansen.

Much has in the last years been written about the influence of Christianity on the political and social development in Uganda and even more seems on its way. The following is not an attempt to walk over the same ground once more, even if some of the same material will be used. There is, however, an aspect which has not so far really been taken into consideration and which could turn out to be a profitable angle from where to look at the religious and political situation in Uganda during the establishment of colonial rule. This aspect is the question of religious liberty and tolerance in connection with the missionary activity in Uganda. - Experience from European secular history and Church history indicates that it often can be profitable to isolate this problem and look at it in its religious, political and social context, not forgetting the important role the concept of religious liberty in itself has played in the whole historical development in various fields.

The following is then an attempt to investigate if the question of religious freedom was of any significance in Uganda in the 1890's and the beginning of this century and further which concept of religious freedom was in use. The religious wars, the struggle between two Christian parties, complaints of religious grievances are so well known phenomena from Uganda in this period that further arguments for Uganda's suitability in raising such a problem seem unnecessary.

The background:

For the whole setting of the problem raised here three factors should be born in mind. - The first question is to what extent religious freedom was taken into account in the colonial framework. In the 1880's this problem was discussed in connection with King Leopold's Congo, and certain rules were approved at the Berlin Conference 1885 and later at the Brussels Conference 1890, not only covering Congo but applicable over a large part of Africa - with a direct significance for Uganda later on. The provisions from the Berlin Conference are found in Article VI under the characteristic heading "Provisions relative to Protection of the Natives, of Missionaries and Travellers, as well as relative to Religious Liberty". (1) From this Article VI it can be said that the concept of religious liberty is used to cover two spheres. First the contracting powers guaranteed that without distinction of creed, religious and other charitable institutions were free to work for purposes of civilising nature, and further they pledged themselves to protect and favour Christian missionaries and others in similar work. It was thus a guarantee for freedom of the missionary enterprise without taking into account the denominational origin. - Secondly, there was given a description of what is understood by religious liberty and who are covered thereby. "Freedom of conscience and religious tolerance are expressly guaranteed to the natives, no less than to subjects and to foreigners. The free

X) I should like to mention some factors in connection with the preparation of this paper. The material is collected as part of research work for another purpose, and the topic here taken up is a sideline only. Secondly it must be born in mind that only material available in Uganda has been used. Thirdly, that this is a first, unrevised draft.

1) The General Act of the Conference of Berlin, signed February 26, 1895, is printed in A.B.Keith: The Belgian Congo and the Berlin Act, (Oxford 1919), p. 302. - M.Searle Bates: "Religious Liberty: An Inquiry" (London, 1945) touches the problem of religious liberty in the colonies at various places; cf. too C.P.Groves: The Planting of Christianity in Africa vol. III, (London, 1955), p. 9 sq.

and public exercise of all forms of Divine worship, and the right to build edifices for religious purposes, and to organize religious Missions belonging to all creeds, shall not be limited or fettered in any way whatsoever".

It is indicated in this last paragraph that the State pledges itself to neutrality in religious matters and to exercise tolerance. In practice this of course was dependent on every single state and even more on the men on the spot, a fact which was seen soon after the Berlin Conference. Apart from this it seems, however, possible already here to raise the question if there not in the above Article VI can be found a certain incongruence between the first and the second part when it comes to practice. On one hand the state is neutral in religious matters, on the other she pledges herself to protect and favour, among others, Christian missionaries because, as it is stated in the Article, they are aiming to forward "the blessings of civilisation", the underlying link being that both state and missions in some respects are aiming at the same. The question to keep in mind during the following is then if this does not involve a certain bias towards Christianity at the expense of other religions, for instance Islam or African belief, a tendency which could be strengthened by the fact that the signatory powers all at that time could be called "Christian states".

The same provisions concerning religious liberty were repeated 5 years later in Brussels, yet with more emphasis on freedom for missionary enterprise (2). - Britain followed closely these international agreements in her own policy towards overseas possessions or spheres of interest. The Imperial British East Africa Company was granted a royal charter in September 1888, and clause 11 stated clearly that neither the Company nor its officers must "interfere with the religion of any class or tribe of the peoples of its territories or of any inhabitants thereof" except in the interests of humanity; further the freedom of worship should be guaranteed (3). - In the same way protection of missionaries and religious toleration and freedom was secured in the Anglo-German Agreement of July 1890 (4).

It can therefore be said that these principles concerning religious freedom were well known from the beginning of the British colonial enterprise in Uganda. Further can be added that behind all these agreements was in Britain a public opinion which to a large extent was influenced by traditions of freedom and tolerance and which therefore quickly would be aware of encroachments of these rights, even overseas.

Turning from the international scene the second factor which is important for the question of religious liberty in Uganda arises from the missionary method and the missionaries' whole approach to the society in which they did their work. Right from the beginning of the missionary enterprise in the 1870's both the Roman Catholic White Fathers and the Church Missionary Society's envoys more or less deliberately found their place right in the center of the Buganda hierarchial system, that is near the Kabaka (5). The significance of this was that the two missions got a stronghold at the top of this hierarchy and could expand along the traditional lines of authority. It is of course clear that this whole approach is inseparable from the simultaneous "Christian revolution" which will be taken up in the next paragraph. Here it is, however, enough to dwell upon the outcome that the two missions worked with and through the chiefs in the traditional hierarchy (6), while at the same time the missionaries themselves became a source of prestige, resulting in a position as intermediaries between the African leaders and the Administration. The missionary influence put the chiefs in a characteristic

2) Bates, op. cit. p. 99.

3) P. L. McDermott: British East Africa or IBEA (London, 1893) has the full text of the charter in Appendix III, p. 282 sqq.

4) McDermott, op. cit. Appendix VIII, art. X, p. 318.

5) vide for this paragraph D. A. Low: Religion and Society in Buganda 1875-1900 (E. A. I. S. R., n. d.), p. 5 sq.; D. E. Apter: The Political Kingdom in Uganda (Princeton University Press, 1961) ch. 4 and 5.

6) The missionaries were fully conscious about this method; vide e. g.

"Instructions to Uganda Missionaries 23/7-1896 (Eastern Equatorial Africa Mission)-(G 3. A5/L 8 - CMS Archives), where it is said with a parallel to the christianization of Northern Europe in the Middle Ages: "... the Gospel has spread downwards rather than upwards".

double position: on one hand they were political leaders, on the other their status and their being object of authority was utilized to create a religious structure which turned out to be more or less indistinguishable from the political one.

An important consequence of being involved with the only established political order was that it was very difficult to distinguish between religion and politics. Leaving the difficulty for the Africans for a moment, the experience of the British administration was very soon that they in what they considered as purely political matters met the religious factor even from the missionaries.

It is doubtful whether the missionaries really understood this inborn connection between religion and politics due to their own position in and their utilization of the structure of the society (7). Representatives from both denominations stated often that they did not interfere in politics and state affairs. For them it was only a question of a missionary method without any intention of interference to any great extent, and they could point to other mission fields where it was commonly agreed that the same method was in use without the same effects.

The third factor which should be mentioned is the impact of Christianity on the Buganda society - the so-called Christian revolution (8). It is possible to elaborate three elements in this revolution which all, of course, are closely related. First, the presence of three foreign religions of which the two were supported of powerful men from outside provoked a choice for the people and that at an opportune time when the internal situation in Buganda opened the possibility for such a choice. The first element in the Christian revolution is thus the personal one, and the new Christian religion gained adherents who were not dependent on the shifts in the Kabaka's attitude. Hereby was, however, introduced a factionalism into the society which caused new structures in the hierarchy.

The second element is that these new Christian factions became strong enough to oppose the Kabakaship and through a revolution 1888-90 gained control over the hierarchical system to such an extent that the Kabaka was "little more than a puppet of the Christian leaders". "In other words, once the Christians had stormed the citadel of this hierarchical and otherwise indifferentiated society, there was nothing to stop them or the faith by which they were characterised, so long as they could maintain their gains" (9).

In the wake of this revolution can as the third element the emergence of the two Christian parties be seen. After the victory over the Muslim faction, Christianity as such could not any longer give cohesion; the denominational split was too strong - an indication of the missionaries' position - and the two Christian parties evolved who shared the power in the country and established themselves to such an extent that they in fact were the only ladder to power inside the hierarchy. The key principle was no longer obedience to the Kabaka, but belonging to one of the two Christian parties with the Mohammedans as a weak outsider. The Kabaka could no longer be on the top of the ladder playing the factions off against each other; he was forced if only nominally to belong to one of the two. If this in the long run could have brought victory to one of the Christian parties remained to be seen as the things were completely changed with the arrival of the Imperial British East Africa Company on the scene in 1890.

The existence of these two Christian parties has resulted in much discussion: to what extent were they purely political parties under a religious name? how important was the religious factor? is it at all possible to make this distinction with regard to the Buganda society? These are only some of the questions put forward. Without pretending to give a definite answer it is, however, important for the present problem to point out that these two religious parties, including their

7) vide Low, op.cit. p. 10. cf. Macdonald's report part 12, E.S.A. A 1/1.

8) for this point vide Low op.cit; Apter op.cit.ch. 4 & 5.

9) quotations Low, op.cit. p. 9 sq.

respective missionary backing, posed a crucial challenge and possible hindrance to the idea of religious liberty as it was laid down in various treaties. The situation as it met Captain Lugard was simply that allegiance to either Anglicanism or Catholicism was *conditio sine qua non* for a place in the political hierarchy, and it is difficult to deny that religion and politics was mixed up at that stage. The origine of and coherence inside each party was clearly of religious nature even if the primary function of both parties turned out to be a struggle for power, and even if they tried to bring in another division in relating themselves to two different colonial powers (10).

Captain Lugard in Buganda.

One of these powers came in the shape of the I.B.E.A. Company represented by Captain Lugard. In his instructions it is possible to see a certain reflection of the Anglo-German Agreement of July 1890, though the idea of religious liberty is not particularly emphasized; instead the main feature of these instructions is a certain ambiguity (11). On one hand Lugard is requested to be "perfectly impartial", to take a reconciling attitude towards the conflicting interests, and to assure the priests that all religious liberties will be respected. On the other hand, he is told, "You should consolidate the Protestant party and you should attempt by all means in your power to conciliate the Roman Catholics". There is here a clear distinction between the two parties, the reason for which can be seen in the estimate of the situation in Buganda given earlier in the instructions. An anxiety is expressed that Kabaka Mwanga and the Roman Catholics should oust the Protestants. The Company wanted, however, to preserve both parties and to keep a certain balance assuming that this would facilitate the power of the Company in the country, the real purpose for the sending of Lugard's mission. - This ambiguity in his instructions seems thus in practice to link the question of religious liberty up with the whole political development.

On this background it is important first to see if Lugard himself was aware of the importance of the principle of religious tolerance and if it played any role in his realization of the instructions. His diary during the first month of his stay in Buganda does not really deal with this problem, but there does not seem to be much doubt that he now and later too was convinced about the value of religious liberty and honestly tried to bring it to bear in Buganda. In one of his first reports to the company he gave a clear statement in this respect: "I consider that by the terms of the Company's Charter, under which alone I administer this Country, as well as by the terms of my treaty with Mwanga, and in the whole spirit of British Colonial rule, absolute freedom of religion is granted to all Christians and Mohammedans alike". (12) Even Captain Macdonald in his critical report on Lugard's actions in Uganda admitted that Lugard stuck to this principle.

How did Lugard try to bring this principle out in practice and how far did he succeed? (13) - Shortly after his arrival in Buganda he concluded a treaty with Kabaka Mwanga (14). The main feature in this was that Mwanga acknowledged the sovereignty of the Company and placed his country under its protection. Clause 4 in the treaty guaranteed the

10) for the Arab factor behind the Christian revolution and for the whole colonial setting, vide Rol. Oliver: *Some Factors in the British Occupation of East Africa, 1844-1894*, Ug. J. 15, 49, (1951).

11) Sir F. deWinton's letter of instruction 16/9-1890 is reproduced in *The Diaries of Lord Lugard. I - III*, ed. M. Perham (London 1959) vol. I p. 327; - in the following called *Diary I* etc.

12) quoted by Macdonald, op.cit. part 4.

13) the following is not at all a full account of Lugard's actions in Uganda, but limited to aspects where the problem of religious liberty is involved. For a full account vide M. Perham: *Lugard - The Years of Adventure 1858-1878* (London 1956).

14) printed in *Diary II*, p.42. The Treaty is dated 26/12-1890.

freedom of Christian missionary enterprise and promised strict impartiality thus fulfilling the first provision in the Berlin treaty. Strange enough there is, however, no mentioning of religious liberty for all. Indirectly there is to some extent cared for this in stating that all posts in the army and all offices of State shall be filled by merit and qualification "entirely irrespective of creed" (clause 6 and 9) clearly an attempt from Lugard to make the state religious neutral; but there is no positive guarantee of religious freedom what probably best can be ascribed to the whole character of the treaty and does not indicate any sacrifice of principle.

Attached to this treaty was a codicil which Lugard signed at the request of the Catholic chiefs. Hereby did Lugard recognize the validity of the agreement that was concluded between the two Christian parties after their victory over the Mohammedan party in February 1890. Following this agreement the main chieftainships (lo sazas) and the estates were divided equally between the two parties. In an attempt to do full justice to both parties the whole system was very complicated. Every holder of a post in the hierarchy was to be under a superior of another party, i.e. "alternate ranks in one vertical section of the hierarchy should be held by members of opposite parties" (15). But to keep the balance which was the main purpose of this agreement the consequence was that every chief who changed his religion had to give up his political office. - It can be said that Lugard in signing this Codicil fully accepted the outcome of the Christian revolution as this agreement in a way "legalized" the revolution. In pursuing his principles he had to recognize the Christian revolution as the necessary fundament.

It is earlier indicated that the Christian revolution put a serious challenge to the principle of religious liberty. The next step is then to examine how Lugard dealt with this challenge which seems particularly crucial in comparison to the treaty's clauses on offices of State and the Codicil's distribution on a religious basis. - He was in the first months of 1891 faced with 2 main problems which threw light on this dilemma.

First, Lugard arrived in Buganda less than a year after the agreement between the two parties. The division of the country was not yet finished what caused great friction between the two factions. This friction was made further serious as several of the opposite faction of their superior chief were ousted from their shambas (estates) thus bringing near a civil war (16). Lugard dealt with this problem following the agreement between the two parties and tried on that background to implement the division. He did this through the Kabaka and made him state publicly in a Baraza (council meeting) that there should be no more ousting (17). The significance of this policy is that Lugard backed the division of the country on a religious base. An example on this is to be found in his attitude to the issue of dividing the Sese Islands (18). The Kabaka was opposed to this as he claimed the islands as regal property. "I replied that even so, the question of religion and religious parties had now entered into Sese, and therefore it must be divided; in Busoga and other tributary states there was as yet no question of religion, and hence no need for division".

15) Macdonald, op.cit Part 3 gives a detailed description of the system; quotation from Rol.Oliver, *The Missionary Factor in East Africa* (London, 1952), p. 143.

16) Diary II, p.80, entry 6/2-1891 and following days, cf. Lugard: *The Rise of our East African Empire* (London, 1893), vol. II, p.71 sqq.

17) *ibid.* p. 103; entry 27/2-1891.

18) *ibid.* p. 86; entry 16/2-1891; p. 99; entry 25/2-1891.

19) quoted Macdonald, op.cit. Part 4, also in Diary II, p. 109: entry 5/3-1891.

What is now the implication of this acceptance of a religious division of the country for the religious liberty? Leaving for a moment the significance with regard to the Africans the question can be asked if this religious division had any significance for the missionary work. It is not explicitly stated if the division of the country was tantamount to a division into spheres of influence between the two missions. A remark in one of Lugard's earliest reports to the Company seems, however, to approve this. In connection with nominal Protestants' going over to the Catholics it is said that this will prevent "their admission into those estates for the purpose of propagating their creed" (19). This impression is further supported by the earlier given example of the division of the Sese islands. During the discussion Kabaka Mwang stated that though opposed to a division he would allow both sides to teach there - implying that this was not normal practice. A further indication of Lugard's wish to avoid controversy between the two missions is given in his discontent with the presence of the two rivals in Busoga (20). - It seems fair to conclude that the religious division of the country involved a certain limitation in the freedom of the missionary enterprise, in other words a slight violation of the promise from the December treaty for the benefit of preserving peace in the country

It is also clear that the division of the country between the two Christian parties tried to freeze the balance permanently, but hereby were several offices in the state made dependent of a certain creed. This is in particular illustrated by the second main problem that Lugard was faced with: the question of men changing their religion and in that case forfeiting their offices and estates (21). Lugard had agreed to this in the Codicil without clearly seeing the implications. First in March 1891 these evictions became serious as many turned Catholics following the Kabaka's creed. Naturally, the Protestants stuck to the agreement, whereas the Catholics asked for religious liberty. Lugard supported very reluctantly the Protestants' case because he for political reasons wanted to keep status quo between the two parties. But he saw clearly that this was a break of the absolute freedom of religion, and he tried in various ways to diminish the unfortunate consequences.

First, he sought to limit the number of people who could be object for such an eviction, and secondly he put a time limit of 2 years on the duration of the agreement, whereafter there should be absolute freedom. - It can clearly be read out of Lugard's whole handling of this problem how weak the ground was for the introduction of religious liberty, however good the intentions were. Lugard and the Company could not afford to look only at the ideals. This became clear when Captain Williams who was left in charge during Lugard's absence in the last part of 1891 tried to introduce religious freedom and to forbid evictions. Lugard's comment was that Williams probably had not understood that even if it was called religious freedom it had little to do with religion, but more with political implications (22).

Lugard instead seemed to take another course which aimed at loosing the connection between religion and politics, indicated e.g. by his opposition to the practice that people on many estates did not work for and did not bring their products to the chief if he was of the opposite creed. Lugard brought it forward on a Baraza that the relations to the chief should be independent of religion - in other words an attempt to uphold the chiefs' authority without mixing it up with religion. In connection with this he also tried to make the estates the property of the individual and not of the religious sect (23).

20) Lugard, *The Rise...*, p. 102, cf. R.P. Ashe, *Chronicles of Uganda* (London, 1894), p. 164.

21) *Diary II* p. 107, entry 5/3-1891 and following days, cf. Lugard, *The Rise...*, p. 95.

22) Williams to Lugard 12/9-1891 and Lugard's comments in *Diary II* p. 400.

23) *Diary II* p. 89, entry 17/2-91, cf. p. 101 and 103.

The same intention can be found in his attempt to accomplish that the Kabaka should not represent parties and not favour the Catholics but take an impartial line and be king for all his subjects (24). - A third indication of this policy is his attempt to limit the missionaries' influence and advisory position in non-religious matters. He asked the chiefs not always to consult the missionaries, and he impressed on the latter of both creeds "that their business was to teach their religion and ours to settle the country" (25). - Lugard's efforts to separate religion and politics to the largest possible extent did not seem to have had much success. His own background was obviously pretty weak as he had recognized a religious division and the consequent limitation in religious liberty. The missionaries emphasized this fact by stating that a distinction was impossible under the circumstances, and it is most unlikely that the African chiefs in their characteristic double position in church and state could grasp Lugard's wish for separation.

Lugard got, however, another possibility to create new conditions for whole work and his efforts to develop religious liberty. The war between the Catholics and the Protestants in January 1892 resulted in a Protestant victory with the help of Lugard. Many different motives were behind this war whereof some already are mentioned here. For our purpose it is, however, most important to emphasize that the war changed the balance of power between the parties and thereby gave Lugard the opportunity of revising the treaty and codicil from December 1890.

During the negotiations before the new treaties Lugard often emphasized the need for religious freedom and tolerance. (26) A result of this can be seen in the first of the treaties, the one with Mwanga March 30, 1892 (27). The words are mostly the same as in the Treaty of December 1890, but the clause on missionaries is added, "There shall be perfect freedom of worship. No one shall be compelled to follow any religion against his will". These words are obviously stronger than in the old treaty, a result of the experiences from the previous period. - The crucial question for the realization of religious liberty was, however, in which way the division of the country was carried out. It was soon after the war obvious that such a division was needed to satisfy both parties. The arrangement was made in an agreement between Lugard and the Catholic chiefs, dated April 5, 1892 (28). The Catholics obtained the large south-western province of Budu while the Protestants got 6 provinces and the Muslims later on 3. This was a more straightforward distribution than the previous one, and when things were settled problems of evictions and of resigning by change of religion might be less. The situation was, however, still that a man in one of the offices of state was asked to resign if he changed his religion, but the number to take into account was smaller. - Lugard later concluded a treaty with the Mohammedans whose three provinces significantly were sandwiched between the two Christian parties (29). The inclusion of the Mohammedans can be seen, apart from political expediency, as an indication of that Lugard now was in a stronger position to extend the ideal of religious liberty.

Further can be added that Lugard in connection with this redistribution laid down rules which should secure the individual a certain liberty. In an explanation to the treaty with the Catholics Lugard made a distinction between religion as such and the armed political parties which had just fought the war. Only the latter were covered by the division whereas there was no restriction on religion as such. People were free to settle in which province they wanted, and they could not be expelled in the case of changing religion (30)

24) Ibid. p. 90, entry 18/2-1891, cf. p. 104 sq.

25) Ibid. p. 100, entry 25/2-1891, cf. Diary III, p. 168 and 215

26) Diary III, p. 47, entry 5/2-1892; p. 60, entry 12/2-1892.

27) Parliamentary Paper C. 6848, p. 96.

28) Ibid. p. 58, cf. p. 58.

29) Ibid. p. 59, cf. Diary III, p. 240 sqq.

30) Ibid. p. 59, Diary III p. 153 sqq and p. 259.

It is clear from this that Lugard succeeded in strengthening the principle of religious liberty, but it is equally clear that this principle still was connected with the political development. Lugard agreed to institutionalize the Christian religion, and this caused a limitation of religious liberty. Lugard when attacked defended himself by saying that the parties were purely political and had nothing to do with religion (31). For our problem it is, however, important to remember that the origine of the parties first of all were religious and - as we later will see again - that even if Lugard looked at the things as a struggle for power, the effects were of religious nature; Lugard's distinction was neither accepted by the missionaries nor by the African chiefs.

Sir Gerald Portal's mission to Uganda.

Already before Lugard's departure from Uganda in the middle of 1892 it was clear that the Company for economic reasons was unable to stay on. In the long discussion whether Britain was to give up Uganda or not, it was decided to send a mission under the leadership of Sir Gerald Portal, Consul General on Zanzibar. When he arrived in March 1893 he was the first real government official on the scene. His analysis of the situation after Lugard was therefore of special interest (32). The striking point for a newcomer was the distribution of provinces among the religious sects. It was immediately clear for Portal that behind this was the fact that religion and politics were completely mixed up and that the religious and political parties were identical. It was further obvious to him that this close connection caused that the missionaries on both side were "the veritable political leaders of their respective factions". He commented on this in the following terms: "The whole history of Uganda for the last ten years is more worthy the Middle Ages, or the days of the Edict of Nantes, than the end of the nineteenth century" (33), but on the other hand he accepted this situation as a fact and as the given framework for some years to come. - In his analysis Portal dwelled at two points. Firstly, he looked at the effects. He saw that the missions utilized the structure of the society and worked through the chiefs which resulted in a lot of converts or evictions as people in inferior positions either had to embrace the same faith or be deprived of their position - in other words "the race for converts.... is synonymous with a race for political power". Secondly, taking the situation as it was, he looked at the actual distribution between the two Christian parties and he found that the Catholics had not been treated with justice and further that this would preclude a more permanent settling of the country.

Only in this last respect Portal found that he could do something. Characteristic for his whole approach he summoned the two Bishops as he - quite contrary to Lugard - accepted them as the real leaders of the parties and got them to sign an agreement which they promised to recommend strongly to their followers (34). The intention was to remove some of the more obvious Catholic grievances and give them a more significant role to play in the affairs of the country. The main provisions were a doubling of the main offices of state and additional territory to the Catholics.

This agreement was later signed by the chiefs of the Protestant and Roman Catholic parties. One important consequence was that in various forms of administration Catholics should only deal with Catholics and so on for the Protestants, in particular with regard to jurisdiction. - This was so far the strongest expression of a separation between the two parties, and probably as a sort of counterweight the clearest statement so far on religious liberty was inserted by Portal

31) The Rise., p. 97; vide also Lugard's biographer M.Perham, opcit. p.382

32) vide for the following Parliamentary Papers C. 7303: Portal to the Earl of Rosebury 24/5-1893.

33) Portal, The British Mission to Uganda in 1893 (London, 1894) p.226.

34) Parliamentary Papers C. 7109: Portal to Rosebury 8/4-1893.

in the agreement. "There shall be absolute freedom of religion throughout Uganda: every person shall be at liberty to follow any religion, creed, or superstition, according to his choice: no person shall suffer any injury, loss of property, or restriction of liberty for any such profession or for any change in his belief" (35).

If Portal did not think he could improve the situation in Buganda very much he tried by another move to hinder that a similar development should happen in the neighbouring countries. He therefore asked the two Bishops to come to an agreement on spheres for missionary extension outside Buganda. Probably bearing in mind the provisions from the Berlin and Brussels Treaties on freedom for missionary enterprise he emphasized that he himself could not take any official part in the discussion and that an agreement only could have the character of a mutual understanding between the two heads of missions. Even such an unofficial gentleman-agreement between Protestants and Catholics was exceptional for that time, and the Protestant Bishop Tucker strongly claimed the right to go everywhere (36). But the Bishops understood Portal's point and accepted temporarily to respect spheres of extension. In the meantime they would refer the problem to their home authorities. Portal later urged his own government to use its influence on these authorities for approval of an arrangement for a 5 or 10 year period (37).

The agreement did work for a couple of years, observed by the missions as well as by the administration. It has, however, earlier been said that the Government by treaties was obliged to freedom for missionary enterprise. When a third mission in 1895, the Catholic Mill Hill Fathers, planned to work in the eastern part of Uganda, the Government had to make a decision, as this area was assigned to the Protestant C.M.S. - The Commissioner of Uganda, Col. Colville, reported the matter to the Foreign Office and expressed as his personal opinion that he was not in favour of limiting one sort of religious activity to a certain area; in the case of Uganda he was of the opinion that the more the two present missions intermingled the sooner would the relations improve. He therefore recommended the Government to cancel the agreement (38).

When the Government in accordance with this recommendation informed the missions in Uganda about the cancellation Bishop Tucker - surprisingly enough when remembering his answer to Portal - protested vigorously (39). He did not deal Colville's optimistic view and wanted still the state's help to avoid difficulties, whereas the Government took a neutral point of view. It can be added that the Colonial administration some ten years later in exactly this area was faced with a situation of strong tension between the two missions. To avoid disturbances which could affect the whole district the Governor tried to restore a division of spheres of influence on a voluntary basis, but this time the missions turned it down (40).

The Colonial Administration and the safeguarding of religious rights.

After Portal's arrangements the country was somehow settled politically and territorially between the parties. The new Colonial administration fully recognized the division between the parties as it was seen when two of the Mohammedans' three provinces after their rebellion in July 1893 were distributed between the two Christian parties (41). (It should here be born in mind that Lugard's promise of liberty

35) The Agreement is printed in Parliamentary Papers C. 7708, p.8.

36) Tucker's own account of the meeting in his "Eighteen years in Uganda and East Africa", (London, 1908), ch. 20.

37) Parliamentary Papers C. 7109: Portal to Rosebury 8/4-1893.

38) Colville to Earl of Kimberley 4/4-1895, pr. Confidential Prints Part 41.

39) Tucker to Consul General, Zanzibar, 15/5-1895, pr. ibid.

40) Secretariat Minute Paper (S.M.P.) 318/1908, E.S.A.

41) Macdonald's correspondance from July 1893 in A 2/1, A 3/1, A 32/1 & A 33/1, E.S.A.

for the individuals and Portal's declaration not per se implemented religious liberty.) The question is then if the British Administration now when it was in a stronger position did anything to secure religious liberty. There were still reports on evictions and infringements on religious ground (42), and it was reported that a Roman Catholic chief had changed his religion and given up his position, although voluntarily (43).

The first commissioner in Buganda was Col. H. Colville who arrived in November 1893. Soon after his arrival he had to work out certain rules with regard to change from one religion to another. Two cases were presented to him, and as they were the first since Portal's allotment of Catholic and Protestant spheres the decision might form a precedent for future cases. Both cases showed on one hand the intentions of the British Administration, on the other hand the difficulties (44).

The first case was that the Kabaka expressed a wish to turn Catholic again and that at a time when Colville had to go to war against Bunyoro. Colville persuaded him then to wait to a more suitable time which brought a protest from the Catholic Bishop Hirth saying that the Kabaka should be free to choose his religion and that this only could be a political question for those who still wanted to confuse religion and politics. Colville answered that he disagreed; this was certainly a political question as the change could have disturbing effects on the whole country in the present situation.

Related to this problem is the second case brought forward by Bishop Hirth. A Protestant woman in possession of considerable properties had changed to Catholicism. There was now a risk that the old custom of depriving her of her position should be used, what would be contrary to the agreement with Portal. Hirth then asked for an assurance of complete freedom of religion. - Colville issued a proclamation signed by himself and Mwanga in which he took the opportunity to lay down rules to realize Portal's clause. A person changing his religion cannot be turned out, nor can he turn any of his people from their estates because of their remaining of another religion, they are free to choose. And in spite of changing religion the property must be under jurisdiction of the province in which it is situated. - This was thus a safeguard of property and position, but Colville added another proclamation which further secured the freedom: A chief could not use his traditional rights and proscribe his people to work on buildings of another religion than their own.

Colville understood that this last case could be very important as it could be expected that many might follow the Kabaka if he later changed his religion. In that case numerous claims could be raised regarding a redistribution of the country. He foresaw, however, endless troubles if he was to sanction this, and he chose another alternative as he tried to loose the distribution of the country from its religious background and just treat it as an administrative arrangement which once done could not have religious complications. This was laid down in a "Draught of policy to be pursued in the event of any Waganda chiefs changing their religion" (45) given to his deputy in Kampala but not published as experience could bring corrections. - In this Draught any redistribution of chieftainships is ruled out. Change of religion shall not affect the land tenure nor will it change the rights held by chiefs. The feudal power of a chief in a district will remain intact whether his subordinates are of the same religion or not.

42) Memo from Bp. Hirth 14/1-1893; Hirth to Portal 24/3-1893; Apolo Kagwa to Berkeley 6/5-1893, all in A 2/1, E.S.A.

43) Macdonald to Consul General, Zanzibar, 21/10-1893, A 32/1, E.S.A.

44) Correspondance from December 1893 can be found as in footnote 38; most of the letters printed in Parliamentary Papers C. 7708.

45) dat. 12/12-1893, A 3/1 E.S.A.

These proclamations by Colville were submitted to the Foreign Office. The answer was an approval of his policy, but it reserved the right to see how it would work in practice (46). It is interesting to notice that the Foreign Office did not refer to practice in other parts of the world.

This whole policy of separating religion from politics in which Colville was more successful than Lugard because of his stronger position was bound up with a rapprochement between the two parties. This was in particular difficult because the Catholics felt themselves as the losing part after Portal's distribution. The result of this was, the Catholic Bishop Hirth complained, that many left their areas and thereby their religion, strongly encouraged by the Protestants. (47) The Commissioner answered that this was a religious problem and that he under no circumstances could interfere in men's religious convictions as freedom of religion was granted to all. He further asked Hirth to enjoin on his people "that religious belief is not necessarily the same thing as politics". But Hirth claimed that these two things were interwoven, and he went on to draw a distinction between European ideas of justice and Kiganda interests and prejudices. -- This interesting point is unfortunately not developed further. It is the first time in connection with the question of religious liberty that there is touched on the problem what would suit the Africans best. -- It must, however, here be remembered that the two missions' approach to religious liberty often could be seen in line with their own position. Under Lugard the Protestants were in a weak position and not too happy about religious liberty, and later - after Portal - the Catholics took this line.

It is interesting to notice that Colville's concept of religious liberty did not only include Christianity. He was aware of the risk of a certain bias towards the Christian missions. When Bishop Hirth complained over grievances against the Catholics, Colville stated that he had a duty "to devote equal attention to the welfare of each of the four sects into which Buganda are divided", and to do justice to all - "more especially the Mohammedans and the adherents to the aboriginal belief of this country, who have no European taking a special interest in them" - he had to obtain fuller information than from one source (48).

He also took opportunity to impress on various people the importance of religious liberty. When a Catholic Father complained over Kamswaga, king of Koki which then was outside the protectorate, Colville none the less took up the case and wrote to the king: "I believe that you are a Protestant, but that is no reason why you should try to prevent other people serving God in the way they think best" (49). - It is thus to be noticed that the new colonial administration really supported Portal's declaration of freedom and tolerance by practical measures. One of them could even say that it was one of the principal objects for Britain to secure religious tolerance for all (50).

The problem of religious liberty outside Buganda.

It should now be clear that the whole question of religious liberty in Buganda is closely connected with the presence of two religious parties and the mixing of religion and politics. To avoid this situation outside Buganda Portal arranged a division of spheres of influence between the missions. This unofficial agreement was, however, cancelled in 1895 and soon after could missionaries of the two denomi-

46) pr. C. 7708, p.19.

47) Material to this can in particular be found in Macdonald's discussions with Bp. Hirth in July 1893 about the distribution of the former Islamic provinces, A 3/1, A 2/1, A 32/1, E.S.A., and Foreign Office Confidential Prints.

48) Colville to Hirth 28/4-1894, A 3/2, E.S.A.

49) Colville to Kamswaga 12/12-1894, A 3/2, E.S.A.

50) Ansorge to Colville 18/12-1894, A 2/3, E.S.A.

nations be found in the neighbouring countries what in many places resulted in accusations against each other, in rivalries and in demands to the colonial administration to secure the freedom of religion. As the missionary method was the same as in Buganda, it came consequently often to a religious division of the chieftainships, and when many people observed the same denomination as their chiefs the result was a division further down in the society. -

As an example can be mentioned that the administration in 1896 reluctantly had to accept a religious division of Southern Bunyoro when this territory was incorporated in Buganda (51). It was at that occasion strongly emphasized that a Catholic province only means that a Catholic chief is in charge. The inhabitants of this province had a complete individual freedom and missionary enterprise was entirely free as in all other parts of the protectorate.

This solution corresponding to the Buganda pattern was, however, not the only one. The different background in the various provinces had to be taken into account and the crucial factor was probably that the missionaries arrived after the administration as they since the days of Lugard had the practice to ask for permission to go outside Buganda. We shall here only select the Kingdom of Toro as an example of which role the problem of religious liberty could play when planted in another ground than Buganda.

Toro in the 1890's owed its existence to the arrival of the British administration as Lugard in 1891 had separated it from Bunyoro and made it to an autonomous unit and reinstated a member of the royal family, Kasagama, on the throne as Omukama. Catholic missionaries arrived late 1894 and worked in competition with the previously arrived Protestant evangelists who were not covered by the division of spheres. In 1896 the first Protestant missionary arrived. Important is it that Kasagama was a Protestant from his early contact with Christian Baganda (52).

Hereby are the four different powers enumerated which from 1895 played the important role in the development of Toro: the British resident, Kasagama, the Catholic priests and the Protestant missionaries. Various combinations were possible, and tensions on various levels soon made Toro a hothouse in which religious differences played a substantial part. Hardly in any other district came the problem of religious liberty to play so decisive a role as in Toro.

Bad relations developed soon between the first British resident, Capt. Ashburnham, and Kasagama, and religion was quickly brought in as Ashburnham accused the C.M.S. representatives of unduly taking Kasagama's part against the administration, covering themselves behind a "misplaced sympathy on religious ground" (53). Soon the Catholic Father in Toro complained to the Commissioner against the Protestant evangelists when he accused them of having assisted in the removal of a Catholic chief, and he blamed the administration for not observing religious impartiality (54). Later came complaints against the C.M.S. missionary A.B. Fisher who was accused of using promises and threats of political sort to bring people - in particular chiefs - into his own denomination (55), and so it continued through the whole 1896. Behind most of these accusations were often rumours and misunderstandings, but it shows how tense the religious feelings ran and how vehemently the two missions fought to establish themselves. Even a court case had to be taken to Kampala because of this atmosphere in Toro (56), and the resident complained that the religious question took all his time.

- 51) Berkeley to Marquese of Salisbury 19/11-1896, pr. Confidential Prints Part 48 p. 89, cf. K.Ingham, *The Making of Modern Uganda* (London, 1958), p. 66.
- 52) re Toro, vide D.A.Low: *The British and Uganda, 1862-1900* (unpubl. Ph.D. thesis, Oxford University, 1957) p. 385 sqq.
- 53) Ashburnham to Berkeley 18/12-1895, A 4/3, E.S.A.
- 54) Fr. Guillermain to Berkeley 28/2-1896, A 6/2, E.S.A.; Berkeley to Fr. G. 24/1-1896, A 7/2, E.S.A.
- 55) Ashburnham to Berkeley 4/5-1896, A 4/5 E.S.A.
- 56) Sitwell to Berkeley 1/6-1896, A 4/5, E.S.A.

In this situation both the Catholic fathers and the British Administration turned to freedom of religion. In extraordinary strong terms the Commissioner pledged the administration to absolute neutrality in religious matters and to non-interference in the individuals' religion: "religion is a purely personal matter in which each and all are at liberty to follow their private inclinations" (57). He asked the resident in Toro to call Kasagama, the chiefs, and other heads to a meeting and lecture for them about the principle of religious liberty.

Capt. Sitwell, the resident in Toro, did this and continued with the campaign in the following months. The administration concentrated especially on Kasagama, as he was the key person, but without success. There came constantly reports about actions to the contrary and he was heard saying that he only wanted Protestant chiefs and - even stronger - that there was only to be one religion in Toro and that Protestantism (58).

The Commissioner to some extent understood Kasagama's difficulties as he recognized it could be difficult in Lutoro to explain to him that while his subjects should not take part in work for Catholic purposes he himself as ruler should treat all equally and even help to create facilities for the Catholic mission and not be influenced by religious differences (59). -- When all these efforts did not bring any result the resident and the Commissioner started to discuss if Kasagama should be removed from the Omukamaship and the country administered directly of the resident or through Buganda (69)

It is possible to recognize some of the same features that were found in Buganda with regard to religious liberty. But it is probably more profitable to look at the differences in the two situations.

- To understand the Administration's point of view it must first be remembered that this was established before the arrival of the Christian missions. Where the officials in Buganda had to deal with a society strongly penetrated and divided by Christianity they had in Toro a society which was not yet divided and where the ruler tried to keep it undivided by excluding one of the two denominations. The administration wanted just as much as Kasagama an undivided society and a strong Omukama through whom they could administer the area in the easiest way, but they could certainly not approve of his methods. Where he sacrificed religious tolerance they had to stick to this principle and create room for both denominations. They therefore tried to minimize the consequences of the religious split by separating politics from religion and make Kasagama a ruler on a non-denominational basis, and because of their early start they had a better chance to succeed than it was the case in Buganda. They were on the spot with a certain strength in guns and manpower, and they did not have to wait until the political situation was suitable for the idea of religious liberty; they could to some extent mould the situation themselves.

It can be said that the administration and Kasagama in many ways were aiming at the same. Further, it must be remembered that Kasagama owed his position entirely to the British Administration. Why then this disagreement over the fundamental question of religious liberty? A somewhat similar question was raised already in these days. Capt. Sitwell heard some of the chiefs asking "why Kasagama does not do as Mwanga does and let people have what religion they like" (61). This reference to Mwanga is very important as a comparison between Kasagama and Mwanga and seems to bring us some sort of answer and explanation.

- 57) Berkeley to Sitwell 18/5-1896, A 5/2, E.S.A.
- 58) Sitwell to Berkeley 30/6-1896, A 4/5, E.S.A.
- 59) Berkeley to Sitwell 11/11-1896, A 5/2, E.S.A.
- 60) Sitwell to Berkeley 30/6-1896, A 4/5, E.S.A.
- 61) Sitwell to Berkeley 10/8-1896, A 4/5, E.S.A.

The most important difference between Buganda and Toro with regard to Kingship in the 1890's is that while as earlier stated Mwanga was dependent on support from one of the two parties and in many ways was a puppet, Kasagama for his part had not got the problem of party division. He knew the situation in Buganda fairly well as even Capt. Sitwell bore witness to (62), and he could expect the same result with regard to his own position. A two party system might create a ruling class which would diminish his own position and probably even split the country whose unity was of a rather new date. The source of power would no longer be the Omukamaship but rather the representative for the colonial power. He then decided for the Protestants - a religious conviction cannot at all be overseen - and tried to exclude the Catholics. In this he would probably have succeeded had it not been for the third factor, the presence of the colonial administration which guaranteed the presence of both missions and instead tried to make him accept the ideal of religious liberty and separation of religion and politics, an ideal which was completely new to him and appeared a rather risky one.

In this conflict Kasagama had more or less to give in faced with the superior power of the Administration. Soon after the year of crisis 1896 the relations were improving, and Sitwell could write in a report that Kasagama was trying to do what he (Sitwell) wanted. Kasagama had also gained more control over his chiefs; he needed, however, still control as he did not give the Catholics equal rights (63). - This brought still complaints from the Catholic Fathers, and they asked in the end for a fixed arrangement after the Buganda pattern to secure the Catholics who were treated as rebels (64).

This request caused an interesting reaction from the Commissioner which once more throws light on the difference between Buganda and Toro and the difference in colonial policy. - The acting Commissioner Ternan would not even consider the possibility of such an arrangement to safeguard the religious rights. The administration was capable of that role. In consequence of this Ternan a little later proposed quite another solution. As Kasagama was a "somewhat intolerant Protestant" it was better that the British resident took more direct part in ruling the country. The whole population of all denominations would look to him as "their supreme chief", and they would quickly learn to have no undue fear of Kasagama's influence, which would eventually become little more than nominal (65). - It seems clear from this that the Commissioner here in Toro did not have to take into account a Christian revolution like the one in Buganda. Instead of the patient struggle to enjoin the principle of religious liberty in the leading parties, he could in Toro afford the solution to introduce it himself directly. - The same principle of letting the Administration guarantee the religious rights was even stronger expressed when Ternan converted a refusal to build a little church for a minor group of Catholics to a permission with the following explanation: "It is of course extremely necessary to make the people understand thoroughly that the interests of the minority are as well guarded as those of the majority, and that the decisions in such questions do not lie with the native chiefs, but are matters of interests to H.M.'s administration" (66). At the same time he deplored strongly the Catholic Fathers' position as intermediaries between the Catholics and the Administration and added "that the closer the clergy adhere to their spiritual duties and the less they encroach in political matters and those affecting the administration of justice, the sooner will the day arrive when the political differences based on religious animosities shall cease" (67).

62) Sitwell to Berkeley 10/8-1896, A 4/5, E.S.A.

63) Report on Toro District 1897-98, 4/6-1898, pr. Confidential Prints Part 56.

64) Pere Achte to Ternan 20/7-1899, A 6/6, E.S.A.

65) Ternan to Bagge 8/9-1899, A 5/7, E.S.A.

66) Ternan to Bagge 8/9-1899, A 4/21, E.S.A.

67) Ternan to Pere Achte 22/7, 1899, A 7/5, E.S.A.

The special situation in Toro thus lead the administration to take a stronger line in pursuing religious liberty than in most other places, and the consequence seemed at one time to be that the officials would engage themselves in the realization of this liberty simply by using the means of direct rule. What the result would have been was not to be seen. The following year Sir Harry Johnston came to Toro with the task here as elsewhere in the protectorate to organize the administration. In the Toro Agreement Toro was made more independent of the neighbouring provinces and the Omukama's position was strengthened (68). This opened again the possibility for strong religious rivalry as the Catholics still were very suspicious of Kasagama. Johnston tried to meet this danger by a gesture towards the Catholics as he arranged for them to have a representative at Kasagama's court. He further recommended the Fathers strongly to recognize the actual situation: to accept Kasagama as head of Toro and as Protestant, and to stop agitation against him (69).

Concluding remarks:

We have here dealt in detail with two provinces in the Uganda protectorate and we have examined how the problem of religious liberty developed in different settings. It is possible to go to other provinces and examine the same problem and probably get a different result as the outcome is dependent on the African background and to a large extent on the personalities of British officials and missionaries.

Certain generalizations can be made from this brief survey. To begin with the question was asked if religious liberty was of any significance in establishing colonial rule in Uganda. It seems without doubt that this was the case and for two reasons: firstly, the British were committed to the idea of religious liberty as such, seen from its European context, and they found it valuable to pursue overseas. Secondly, it was often politically expedient for the colonial administration to introduce religious liberty. How they exactly made use of this principle was very much up to the man on the spot as the Foreign Office took a rather pragmatic view when asked for approval of this or that step.

Seen more from the point of view of the African societies it can be noticed that this idea of religious liberty appeared new and difficult to bring to work. It is not the place here to go into the whole question whether this is due to the particular African context in which there is no distinction between the religious and the secular sphere. As we here have met the idea of freedom of religion it is clear that it did not appear in connection with the whole problem about the European process of secularization. The main context in which it appeared was the presence of two competing types of Christianity, each backed by a number of missionaries, and each promised freedom and tolerance by the colonial power. The effects on the African society were in many cases a new division and a hitherto unknown factionalism which was bound to have political implications. A new source of power and authority was introduced which must have more than just religious effects.

The result was a mixing of religion and politics which could not disappear overnight by mentioning religious liberty. The same mixing can be explained by looking at the original African institutions, especially the chieftainships. The common missionary method was to work through these institutions and utilize the traditional pattern of authority. But the colonial power used the same institutions at the same time and placed the chiefs in strange double positions.

We have only covered a short span of years and only dealt with the very first introduction of religious liberty. How it will work in a more established situation remains to be seen.

68) Ingham, op.cit. p. 92; D.A.Low, op.cit. p. 557 sqq.

69) Johnston to Pere Bresson 19/10-1900, A 24/1, E.S.A.

SOME PRACTICAL PROBLEMS ENCOUNTERED IN SOCIAL SURVEYS IN
SUKUMALAND.

J.D. Heijnen.

The program of our team, engaged in a two years research on education in Sukumaland, included two general surveys: one in the urban centre, Mwanza-town, and one in Bukumbi Sub Division, a rural area roughly 15 miles distance from Mwanza-town. Most of our research is concentrated in these two areas and it was considered necessary to collect basic data about the population (educational level, literacy, age structure, tribal composition, religious affiliations, employment situation etc.).

The purpose of these surveys was not only to collect data which could serve as useful background information. It was particularly intended that this information could be used also as a basis for further research. Thus from the general survey in Bukumbi Sub Division a sub-sample of farmers with St.VIII, St.IV and no education will be taken, to investigate the possible influences of (school) education on farming methods. Similarly Miss Varkevisser, anthropologist of the team studying home education, will use the same survey in her field of study to compare the situation for parents with different levels of education.

This approach dictated the solution of the first theoretical problem: execution of the surveys at the beginning or at the end of the field work.

The latter method of course has its obvious advantages. Most important of all is probably the fact that the people, at least in rural areas, will be less suspicious. They (assumedly) would know the researcher as a comparatively harmless man, who also works outside office hours, perhaps even drinks the local beer. Consequently one might expect that cooperation would be better. In a town like Mwanza, with a great amount of mobility among the more than 25,000 Africans this consideration carries less weight. Another argument often heard in favour of the second solution is that the framing of the questions would be easier. Moreover, one would obviously have a better knowledge of local conditions, locally available manuscripts etc. so that an evaluation of missing and required information, the composition of the questionnaire, the recruitment of enumerators as well as the execution of the survey itself would be easier.

Recognizing all this, I believe there is nevertheless an important point in favour of conducting the survey at the beginning of the field period. Namely, the survey, if carefully designed and executed, can provide an excellent starting point for further investigations. It enables the researcher to select a sub-sample according to previously fixed criteria. To give again the example of the farmers: educational standard, age, tribe, religion, location, social status etc. Besides, when working with a team representing different disciplines, the survey can form a link between the members' work and further communication and cooperation.

As already stated, in this case preference was given to an "early" survey. With a view to this use of the survey as a basis for further research, two requirements had to be met:

1. The surveys had to be truly representative of the population as a whole;
2. The various relevant categories (e.g. again our farmers with St.IV education) had to be of a certain size.

Naturally the first requirement is valid for any kind of survey. In practise, however, its application is as a rule severely limited by the available means. In random sampling theory, the size of the sample is decisive for the accuracy of the results and not the size of the universe (assuming that the universe is considerably bigger than the sample). One allows e.g. a 10% error (with 99.4% certainty) and wants to apply this to any category of 10% and more in the sample. Theoretically the required size of the sample in this case would be:

$$\frac{9}{0.1^2} \cdot \frac{1 - 0.1}{0.1} \quad \text{or } 8,100.$$

Similarly, allowing a 10% error with 95.4% certainty, one arrives at a sample size of 3,600, with 90% at 2,435 etc. The text book I used for these computations on the subject simply says: "The greater reliability one requires, the greater the costs." An almost cynical remark in African conditions.

It is perhaps even fortunate, that unless one wants to take a sample of e.g. members of the Primary Societies of the Victoria Federation, there exists as a rule no basis for a pure random sample. Because even if the basis and the necessary funds would be available, this kind of approach is bound to fail. Any theoretically sound method becomes of doubtful validity in a town like Mwanza. Within a period of six months, more than 1/3 of its African population moves from one house to another or to and from the rural areas. This excessive mobility demands a very rapid operation. In fact, unless the whole survey can be carried out within one week, computations of standard errors etc. become questionable.

In practise the only basis for a survey in this part of the world are maps and aerial photographs. If one is lucky, they have been made recently. Thus for Mwanza-town 9 sheets existed, scale 1 : 2,500, based on aerial photographs taken in April 1962. For Bukumbi Sub Division there were aerial photographs of reasonable quality, dated July 1964, scale about 1 : 30,000. If in theory not the required basis, the best substitute that I could hope for. Let us first consider Mwanza-town.

The survey in Mwanza-town.

The geographer smiled and enthusiastically set about numbering the over 6,000 "Private buildings" shown on the map. 1) The decision was taken to aim at a 10% sample, which would probably mean interviewing 1,500 - 2,000 Africans aged 10 and over (this age limit was set because of the wanted data on literacy). By means of a random list 2) the houses to be visited were selected. Next a great number of photographic copies were made covering the nine sheets, to help enumerators and staff find the selected houses. The sample was ready.

In the mean time of course the problem of finding sufficient suitable interviewers had become acute. The 1,300 people to be interviewed were scattered all over the township and taking into account the degree of mobility, speed was essential. It was completely out of the question to enlist a sufficient number of temporary paid enumerators with a suitable educational background. They were simply not available. In my opinion, the minimum requirements for this kind of work are at least some years of secondary education. Thus I had to rely on the help of volunteers. But how to get them?

In my memory, the sun shone brightly, the day we learnt that the Department of Community Development in Mwanza, together with the Institute of Adult Education and the Nyegezi Social Training

1) This of course included latrines, sheds, houses lived in by Asians and Europeans etc. that were simply dropped from the list during the survey.

2) Use was made of Fisher, H.A. & Bates, F.: Statistical tables for biological, agricultural and medical research; N.Y. 1963, p. 134.

Centre were planning to do a small scale literacy survey in Mwanza-town. The purpose was twofold: to collect some data on literacy, and to give the students of the Social Training Centre some experience in interviewing techniques. In order not to impose too great a burden on the students' time and enthusiasm, the C.D. Officer kindly agreed to enlist the help of Secondary school students. In this way it would be possible to work with different groups of students on alternate days and to finish the work in a reasonable time (three to four weeks). Another major advantage was, that in this way a fruitful cooperation could be established with the Government and various local Institutes.

I should like to stress the enormous advantages of such cooperation. It enables the researcher to make use of facilities that otherwise would not have been available. In our case e.g. the C.D. mobile film unit, which proved to be an excellent vehicle to "advertise" the forthcoming survey. Six open air film shows could be given and each time between 400 and 1,200 adults saw the films and heard the explanations given.

Naturally the interest of different Government Departments will vary according to the proposed plan. However, I have the impression that many researchers look upon the Government buildings merely as a place filled with trouble shooters, where at best old and dusty files containing valuable information can be dug up. Besides, an involvement of the Government will probably ensure a keener interest of Gvt. officials in the results.

There is clearly, at least in golden theory, an important drawback when such cooperation becomes visible to the people (e.g. by using this mobile film unit). The image of "independent" researcher has been spoilt, even before the story has been tried. In practice, however, this ideal image is always difficult to establish, if not impossible in developing countries. And I really wonder whether in present circumstances "Bwana Maendeleo" is not a better introduction than "Independent researcher", a term, hardly anybody, even after lengthy explanation, can understand. It goes without saying that, depending on local circumstances, the possible negative reactions of the people towards certain measures taken or advocated by a Government Department, can make it undesirable to establish such visible links. This could do irreparable damage to the project.

One more remark on this subject. The researcher is to a great extent dependent on the Government. Sometimes their express consent is needed for each and every part of the total project. It makes all the difference whether one has to wait a month or half an hour for a letter of introduction for a local official. I am convinced of the fact, that especially the unpopular sociologist or anthropologist can make relationships much easier both for himself and his colleague coming after him, by sending his project outline, preliminary reports etc. to the various key officials. They may find no time to read them, but much goodwill is created and waiting time correspondingly reduced.

Much remained to be done before the actual interviewing could start. One sheet of the map was checked for its reliability. Less than 5 % of the houses were found demolished and a similar number built since 1962. During the survey the houses found demolished were, as far as possible, replaced by newly built houses in the same area. The questionnaire was drafted and tried out during a one-day pilot survey in a nearby village, with help of the S.T.C. students. As with the exception of our own four assistants the enumerators did not have any experience in this kind of work, it was considered necessary to frame the questions as explicitly as possible, to ensure a uniform questioning.

Furthermore, with a view to the limited time available for the preparation and execution of the survey, it was decided to concentrate on education and literacy and directly related subjects and to take only a few of the possible correlations

into consideration. Data about housing conditions, marriage forms and children under 10 years of age, more details about the employment situation have been covered in a second survey, executed six months afterwards. Having used the same sample, it is hoped that this second survey will provide some concrete information about the mobility of the population. Besides, this second survey can provide a useful checking instrument, both in comparing the corresponding figures for the surveys as a whole and in those cases in which the same family has been interviewed twice. Figures of this second survey are unfortunately not yet available.

After training the students 1) the actual interviewing started on March 9th and was completed, as far as the students were concerned, the last week of that month. Afterwards our own assistants dealt with the remaining cases of non-response due to absence.

Altogether 1,777 persons (952 males and 825 females) were interviewed. Although the interviewers returned several times, even late at night and on Sunday mornings, a number of people could not be found present. As far as could be ascertained from the questionnaires and files, their number amounted to 53 (37 males and 16 females). However, in reality as also the second survey proved, the number must have been considerably higher, for the following reasons:

1. There is a number of people in town without a permanent place of residence. They may live in one house for a few days and then move to the next place. Others are practically never present, spending their leisure time in pombe shops etc. In many cases the other inhabitants do not know them and consequently did not mention their existence when asked whether there were other people living in the house.
2. A marked unwillingness can be observed, to talk about other people in the house, neighbours etc. This can go so far, that e.g. a woman refuses to give the name of her husband. Though suspicion naturally plays a part, the fact that she answers the other questions without much ado, presumably indicates that other factors are at stake as well. As a result of this attitude sometimes entire families were not interviewed. Perhaps this is also partly due to lack of experience on the part of the interviewers. No doubt, especially in the bigger houses with ten or more people to interview, they did not sufficiently check whether all rooms had been covered. In how far this has affected the results, remains to be seen. There may be no systematic error.
3. More serious in this respect, was the fact that apparently relatively many children of schooling age were not interviewed. This must be imputed to the fact that people simply forgot to mention them or interviewers forgot to ask. The first survey provided no check on this point as no details about progeny and relatives living with the family were asked. As the second survey showed, such details are necessary and should not have been left out for the sake of short interviews.

The survey was organized in such a way that each day we had about 35 enumerators at work. This naturally posed an extensive supervision problem. Most interviewers had to be shown the houses allocated to them. And one man cannot possibly take a party of 35 students around without drawing too much undesirable attention. Besides, the Social Training Centre students had to be transported from Nyegezi to different parts of the town. Consequently I heavily relied on the cooperation of Mr. J. Swarbrick (Resident tutor Inst. of Adult Education), Rev. W. Moroney (S.T.C. lecturer in Sociology) and the other members of our team. When the students came back from their interviews, we tried to check the questionnaires and correct possible omissions. Nevertheless

1) more about this will be said later.

sometimes "No data" had to be inserted in the different tables owing to the limited time available for the purpose in relation to the number of questionnaires brought in each day. Especially in the beginning this part of the work took much time.

In general cooperation of the people has been very good. There were of course the "normal" suspicions regarding new tax measures. Some other people, notably the unemployed and the prostitutes were afraid that the survey would be used to send them back to their villages, as had been done recently in Dar es Salaam. Goddess Fortune was with us however, the latter measures were not taken until one day before the interviewing for the second survey had been completed. All non-response from these sources could be eliminated by sending one of the team's assistants to those people who initially refused, to explain everything carefully once again.

The survey in Bukumbi Sub Division.

The survey in Bukumbi Sub Division brought its own specific problems. Firstly the basis was completely different. The most recent aerial photographs cannot compete with a 1 : 2,500 map, when it comes to using them as a sampling base. The only relevant equipment at my disposal, a field stereoscope, made very little difference in this respect. The only thing that could be accomplished was a 1 : 30,000 sketch map, showing the most important features including gunguli boundaries, the location of schools, Primary Societies of the Victoria Federation, the cotton ginnyery, Mission hospital etc.

First stratified area sampling was considered, and subsequently rejected as impracticable. The whole area covers roughly 50 miles only. Consequently the squares would have to be very small, which would make it a major operation to spot them with the required exactness in the field. Moreover, with a view to the scattered location of the homesteads, this method would pose practically unsolvable supervision and transportation problems. Thus another basis had to be found.

Administratively Bukumbi Sub Division is divided into seven gunguli, each with a headman in charge. In turn each gunguli is made up by a number of shibanda (sing. kibanda), under a Sub headman. The kibanda is a clear geographical and social unit. It has its own associations, based on sex and seniority like the Kisumba (ass. of young men and unmarried girls with their leader, the Nsumba Ntale) and Kinamhala (older men). The number of homesteads of a kibanda varies between 10 and over 30. In practice the situation is somewhat more complicated, as several smaller shibanda for administrative reasons have been joined together. Thus e.g. Kigoma consists actually of four (sub) shibanda. It soon became apparent that the only possible basis for the survey would be a selection of a number of these shibanda.

Using various criteria: distance from roads, schools, Mission, Primary Societies, size of the mbugas (soil type in the valleys, important with a view to rice growing and pastures) and the expected occupational structure, 13 shibanda were selected, as far as possible spread over the whole Sub Division.

The selection of these rather big clusters naturally entailed a compromise between the two earlier mentioned requirements: representativeness of the survey as a whole and the size of the relevant categories. Thus it was considered necessary to include the main trading centre Usagara (Moslems) in the survey as well as two out of the three minor trading centres, Nyamanore (near the ginnyery) and Kakora (near the R.C. Mission and hospital). Furthermore, the labour camp of the ginnyery (mainly unskilled labourers), another unique feature in the Sub Division, was later added as the 14th unit. It will be

clear, that this stratification meant that the survey as a whole became biased, as the percentage of farmers in reality is bigger than it was in the survey as a whole etc. By grouping the shibanda and separating these strata for a number of computations this drawback naturally could be somewhat reduced.

This approach of selected shibanda proved to be a happy solution, which greatly facilitated the execution of the survey. The second important factor was the cooperation with the Dept. of Community Development. At about this time the Department started a literacy campaign in the Sub Division. During the meetings held in different places on this and other subjects, first the headmen and members of the Village Development Committees and later all the villagers could be informed of the purpose and organization of the survey 1). In addition six open air film shows were staged. Perhaps even more important, however, was the fact that use could be made of the Local Government's, largely traditional, communication system. When e.g. the day had been fixed on which the inhabitants of a certain kibanda would be interviewed, I would contact the headman of the gunguli in which the kibanda was situated. He in turn would pass on the message to the sub headman and the Nsumba Ntule. The latter would call the Mfuji wa Mhembe, who then would go around, blowing his horn and requesting the people to stay at home. On the appointed day and hour, either the headman or the sub headman would take the interviewers to the scattered homesteads of the kibanda. This system generally worked quite satisfactorily. Moreover, it was the only way to interview over 2,000 Africans in a comparatively short period (including second visits due to absence of some people, it took two months). At the same time, it cannot be denied that it was somewhat cumbersome. There was always the risk, especially round the weekends, that one of the above mentioned links would be in the pombe shop when he received the message. And depending on the amount of beer he consumed, he might forget to pass the message on afterwards. Sometimes also our concept of time clashed with theirs. Consequently the headman or his deputy might not be waiting for the enumerators. In the beginning such a situation caused difficulties: e.g. nobody would be willing to take over the responsibility. After the first days, such problems were easily solved.

There were other reasons which made it desirable not to base the survey on an elaborate sampling technique. Although this time the speed of the operation was less urgent because of the mobility of the population, nevertheless the fact remained, that its main purpose was to serve as a basis for further investigations. Therefore it could not take up too great a part of the available time. Secondly this time I expected to get very little help in supervision, which meant that the number of units had to be kept to a minimum if the interviewing was to be finished in a reasonable time.

The problem "where to find suitable interviewers" was solved this time in cooperation with the Agricultural Training Institute Ukiriguru, situated on the boundaries of the Sub Division. In "exchange" for an introductory course in Sociology, given by Mr. Dubbeldam, sociologist of our team, 26 3rd year Extension students were put at my disposal for a period of two weeks, later extended by a few days. This was sufficient to visit all homesteads at least once. Afterwards our own four assistants interviewed the labourers of the ginnery and dealt with non-response due to absence.

The interviewing started in the third week of May and was completed by the 15th of July. Altogether 2,087 people (1,046 males and 1,041 females) were interviewed, all Africans aged 10 and over. It is difficult to assess what proportion of the total population of the Sub Division has been covered, as no 1) In general the number of meetings organized in the dry season is enormous. In one week I counted over 25, at different levels.

reliable population figures are available. The total number of male tax payers was 3,441. Applying a multiplication factor of 4.5, one arrives at a population figure of appr. 15,500. Taking into account the number of casual labourers in the survey and children under 10 years of age, I estimate that about 15 % of the population over 10 years of age has been interviewed.

Some considerations about the questionnaires.

Surveys of this size and especially when carried out at the beginning of the field work period, have their clear limitations, concerning both the number and the kind of questions that can be asked. I believe in general it will be possible only to collect factual data with any amount of certainty on education, literacy, tribal composition, age structure, marriage, migration, employment, housing conditions etc. Subjects like agriculture, politics, social structure, income opinions on various statements demand a thorough knowledge of local conditions and relationships and are therefore much more difficult to control. I admit though, that it makes a great difference what kind of question is asked. Obviously anything like "Do you know the two candidates for the last elections" is different from "Did you vote for the symbol 'House' or 'Jembe'", assuming that the researcher expects a reliable answer.

At least in my case, all questions I tried about agriculture and social structure (kibanda associations) had to be dropped, as the answers were considered unreliable. As it turned out, there were several, partly unexpected, factors at stake. Firstly there is suspicion, combined with the interviewees understandable point of view "to be on the safe side", e.g. some women in "temporary" marriage claimed that the bride price was paid for them. This was said not out of embarrassment, but out of the consideration that adult women for whom no bride price had been paid, could be considered not legally married and thus liable to Personal tax. It makes very little difference then whether only the first few hundred people were suspicious, the whole question becomes of a very limited value. Secondly, the unexperienced researcher will discover prestige factors in unexpected places which bias the answers of the interviewees (e.g. negative attitude of school leavers to kibanda assoc.) In other cases the language problem played a part (vernacular and Kiswahili). Lastly I certainly had an insufficient knowledge of local conditions and custom. Existing literature may be relatively abundant, as in the case of Sukumaland. On some occasions, however, it turned out to be inaccurate, whereas also as a rule local variations are not taken into account.

Naturally there was the pilot survey to try out questions etc. But however useful, it only showed the more obvious mistakes. In practice one is often dependent on the actual possibilities. Thus for Bukumbi Sub Division the pilot survey was conducted by our own assistants, as the students of Ukiriguru were not available at the time. They were Sukuma themselves, whereas only one of the students was a Sukuma. Because of this, any such difficulties the people would have in understanding the meaning of some Swahili questions, were not discovered. Perhaps better qualified assistants would have noticed it, but they were not available. Also the pilot survey was conducted outside Bukumbi, in an area where the people probably had a better knowledge than in some of the more isolated shibanda of Bukumbi Sub Division.

Moreover, the answers to many questions can be checked only afterwards, e.g. answers about the use of fertilizers can be checked in the account books of the Primary Societies. This control is of the utmost importance, if at all possible. In our case it also provided an indication as to the reliability of related questions, such as the planting time of cotton. Both are subject to specific recommendations of the agricultural

Extension Service. If the answers to the first question are unreliable, there is no reason to believe that the second one will be much different in this respect.

Framing of questions.

As has been stated already, the questions were kept as explicitly as possible. At the same time, they had to be simple and short, both for the sake of the interviewer and of the interviewee. In most cases, intricate gimmicks can only do harm. Somewhere I found the following procedure for a literacy test: "A simple statement in English was printed on a form with its translation into the vernacular used in the areas sampled on the reverse of the form.....The form was handed to the respondent upside down with the English translation uppermost. Failure of the respondent to turn the form right-way up enabled the enumerator tactfully to withdraw the form..... as it was clear that the respondent did not have sufficient literacy..... Frequently the respondent would state upon glancing at the form that he could not read English whereupon he was invited to turn it over and look for the vernacular which he understood. None of the respondents were told that they were being tested for literacy..... Depending on the kind of response the respondent made and by careful probing on the part of the enumerator it was possible to make a decision as to whether or not the respondent understood fully the message on the form."

Knowing the difficulties my enumerators had in managing their questionnaires and forms, I wonder why procedures had to be so complicated (In the above mentioned case enumerators were Community Development assistants). It creates an unnecessary source of errors.

Training of enumerators.

In theory again, there is only one solution: a very thorough training, combined with practice in the pilot survey and elsewhere. When it comes to the actual organizing of a survey, this is not always possible. Though naturally I tried to adhere to this principle as much as possible. Thus e.g. the S.T.C. students got a reasonable amount of instruction during their sociology lectures and, at least for the first Mwanza survey, they carried out the pilot survey. In the case of the Bukumbi survey this was impossible. The Ukiriguru students were away in courses elsewhere and eventually only became available for this purpose one afternoon before the actual interviewing started. Consequently I had to restrict myself to a relatively short explanation and one or two practice runs in front of the group. Similarly, for various reasons, the secondary school students got a varying degree of training.

In general I believe it can be said that training varied between a short introduction and a more reasonable amount, though still much short from the ideal. The remarkable conclusion was that those who got a shorter training probably made less mistakes than the others. Could it be that an amount of training between a short introduction and the ideal one (say a week at a stretch) only tends to confuse unexperienced enumerators?

I hope it will be possible to hear some experiences of others on this and other subjects covered (or not touched upon) in this paper.

ASPECTS OF URBAN UNEMPLOYMENT IN UGANDA

By

C.R. Hutton

From the early years of this century, a periodic problem besetting development in Uganda has been shortage of labour, a shortage which was shared by the Baganda farmers who came to depend on hired labour. From the 1920s this shortage was met by increasing immigration of labour from countries bordering on Uganda, notably Ruanda-Urundi, by recruiting agencies and by a growing flow of immigrants from West Nile, Kigezi and Ankole and later from other areas of Uganda. (Powersland 1954)

From the middle 1950s the annual reports of the Labour Department begin to mention periodic surpluses of unskilled labour in towns, co-existing with shortages of labour elsewhere. The last reports of 1959 and 1960 speak of a general surplus of all labour in towns, except the most highly skilled, and of growing numbers of school leavers coming onto the labour market with inadequate qualifications for the rising standards expected by employers. The reports qualify this by adding that unemployment was not a serious urban problem because the unemployed were able to return to their homes when they failed to find work.

Over the last ten years, for a number of reasons, employment in Uganda had been increasing at a slower rate than the growth of production. In addition to a general trend away from labour intensive industries, there has been some reduction in the labour required per unit of output, substitution of capital for labour, which together with increases in minimum wages and the employment of better trained labour have resulted in a narrowed wage structure at a time when there has been rapid increase in population, and a growing number of boys leaving school with no particular skills. (Clark, Baryaraha, Rado and Van Arkadie 1965)

In view of the existence of a body of surplus unskilled labour, a form of unemployment can be said to exist, at least in the major towns. Unemployment in Uganda, however, must be set in the context of a predominately agricultural economy, and there is some danger of imposing industrial Western concepts onto a situation in which they are not entirely appropriate. It is necessary, therefore, to consider the forms of unemployment which exist, and the levels on which they are found.

Lack of employment in Uganda takes the following forms:-

- a) Urban unemployment: a man in town is unemployed if he is willing to work, actively seeking employment and has abandoned all alternative forms of occupation in order to look for work, even though he may not have left his home.
- b) Underemployment: this is both a rural and an urban phenomenon, and may take two forms (following I.L.O. usage)
 - i. Visible underemployment: this covers any form of involuntary short-time or part-time working, including seasonal unemployment which is due to insufficient economic opportunity.
 - ii. Disguised underemployment: this may or may not be short time working, but productive capacity is underutilised, and both earnings and productivity are low. In this form it can apply particularly to family cultivation where a growing population

is being absorbed by the agricultural sector.

By this definition a farmer who has left his land to look for work, and who is therefore not strictly dependent on wage earning, can be considered unemployed if he fails to get work until such time as he returns to farming. Urban unemployment is likely to become a problem, either when boys come from school to look for work, and are unwilling to become farmers, or when numbers of farmers are continually moving into the town and being replaced by others as they return, so that there is a permanent stratum of unemployed in the town although its composition changes.

There is little doubt that urban unemployment in these terms does exist in Uganda, but there is little or no information on the nature and length of the periods of unemployment experienced, the capacity of the men for the work they are seeking, their alternative prospects for obtaining incomes outside the towns, and the means by which they survive while they are unemployed. A Survey was therefore carried out which provided information on these points from unemployed men in Kampala and Jinja.

In the absence of any datum that could serve as a sampling frame, it was not thought possible to base the survey on a random sample, neither was quota sampling practicable owing to the lack of information about the unemployed as a population. A household survey which would cover the unemployed was beyond the resources of the present survey, but it is doubtful whether this would be a very fruitful way of studying unemployment in Uganda as the unemployed tend to be mobile and elusive, besides which numbers of them live in the peri-urban areas where food is easier to come by, rather than in the towns themselves.

There have been two recent surveys of unemployed men in African Cities, one in Dakar, and the other in Brazzaville. Y. Mersadier (1963) had constructed a household frame of 4,000 families in Dakar for use in a family budget survey, and he used this three months later to follow up the unemployed in these households. This time lag had the disadvantage of causing the omission of those who had moved or had found employment, and those who had since become unemployed, but a final group of 400 men was found. In Brazzaville, R. Devauges (1963) invited unemployed men in the Poto-Poto township of Brazzaville to be interviewed. He used a short questionnaire for 486 interviews, and a more detailed one for 141 men selected on the basis of the larger group, stratified by age, education, occupation and tribe.

The present survey was limited to the two main towns of Kampala and Jinja where it was known that numbers of work seekers could be found, and was aimed at locating unemployed men who were actively seeking work and interviewing them on the spot. On this basis a pilot study of 54 men was carried out in the Kampala Labour Exchange, and then 100 men waiting for work outside the Nyanza Textile Industries Ltd factory in Jinja, and 100 men waiting outside the BAT Uganda Ltd factory in Kampala were interviewed inside these factories.* The men chosen were selected from the factory gate as systematically as possible; where there was a queue the man at the head was chosen, where there was no ordered queue,

* I am very grateful to these two firms for their co-operation in this survey.

the man at the middle point of the double gate was taken. If the selected man had been interviewed before, the man next to him was taken. Different interpreters were used for each of the surveys, and interviews were carried out in English, Luganda or Swahili.

The tribal, age and educational distribution of the men who were interviewed are discussed briefly here to give a general picture of the groups as a whole, before going on to the categories of unemployed who were found. The two groups of men from the factories in Kampala and Jinja showed some variation in their general characteristics, but these seemed to derive chiefly from differences in their tribal distribution.

Table One - Tribal Distribution

Tribal group	Kampala	Jinja	Total%	Total No
Baganda	32	25	28.5	57.5
Basoga	3	11	7.0	14
Banyankole	15	2	8.5	17
Bakiga	10	6	8.0	16
Other W. Province	3	2	2.5	5
Iteso	2	11	6.6	13
Other E. Province	7	17	12.0	24
N. Province	5	13	9.0	18
Kenyans	11	6	8.5	17
Banyarwanda	9	4	6.5	13
Other foreigners	3	3	3.0	6
Total	100	100	100.0	200

The Jinja group drew more heavily on the tribes of the Eastern and Northern Provinces, notably Basoga and Iteso, while the Kampala group had larger proportions from Western Province, particularly from Ankole and Kigezi, and also from Kenya and Rwanda. It was striking in both groups that there was a large range of tribes from both inside and outside Uganda, but that the Baganda were the largest single group. All the major tribes of Uganda were represented with the exception of the Karamojong and the Lango neither of whom migrate to the towns in large numbers.

Taken together, the two groups were characterised by their youth, which was related to limited experience of previous employment and some education.

Table Two - Age Distribution

Tribal Groups	Age Groups %				Total %
	16-19	20-24	25-29	30 & Over	
Baganda	37	39	17	7	100
W. Province	21	53	16	10	100
Other Ugandans	32	32	22	14	100
Foreigners	19	45	19	17	100
Total	29	40	19	12	100

The men from outside Uganda, together with the Banyankole and Bakiga tended to be a little older than the remaining groups, but in all tribal groups the great majority were under 25, and relatively few were over 30. There were few very young boys, and those under 20 were mostly 18 or 19.

With this relatively small age range the differences in the age distribution between tribes do not appear particularly significant.

Table Three - Level of Education

Tribal Group	Highest class reached							T.%
	None	P1-P3	P4-P5	P6	J1-J2	J2 with cert	Senior cert	
Baganda	4	9	18	19	33	12	5	100
W. Province	10	19	29	16	5	13	8	100
Other Ugandans	10	13	13	21	19	14	10	100
Foreigners	17	17	25	5	17	19	-	100
Total	9	14	20	17	20	14	6	100

The proportion of those who had never been to school was strikingly low, being 9% of the total, and particularly low among the Baganda. Although the great majority of men had been to school, the general level of education was not very high. Only 6% of the men had received post-Junior Secondary education, and in most cases this had been in the form of one or two years at an unrecognised private school in Buganda. 60% of all the men interviewed had either no education or primary education only, and might therefore be considered poorly qualified for employment by present standards. Of this 60%, one third had never worked before, and would therefore probably stand very little chance of getting work at all in the present circumstances. From the experience of these men it seemed that it has become annually more difficult in the last few years for a boy with little education and no experience to get any work. Those with poor qualifications who had worked before, had usually got their jobs some time ago. Taking all the men together more than half had worked before, but the less education a man had had, the more likely he was to have previous experience of working. The men with the least education therefore, tended to be the rather older men in the group whose chances of employment a few years back would have been more favourable than those of a man in the same situation today. There was little evidence of men becoming unemployed after years of working in town.

It was clear from the material collected that unemployment must be considered as one aspect of the movement between town and country which is continually bringing waves of work seekers into the town. It is therefore important to discover not only why A is employed rather than B, but also the point at which both A and B decide to leave home in order to look for work; in other words, the point at which rural underemployment is converted into urban employment, underemployment or unemployment. It is known that the number of workseekers actually in the towns can vary with the amount of publicity given to employment prospects, so that the announcement of a new factory will bring people looking for jobs before the factory is built. An unemployed man who

has the means is likely to return home and wait for news of new employment before returning to the town, so that the number of men in town without work at any one time does not give the full picture of the extent of potential unemployment which is existing as disguised rural underemployment. The following diagram expresses in simplified form the factors which operate in bringing these men to town.

Diagram One

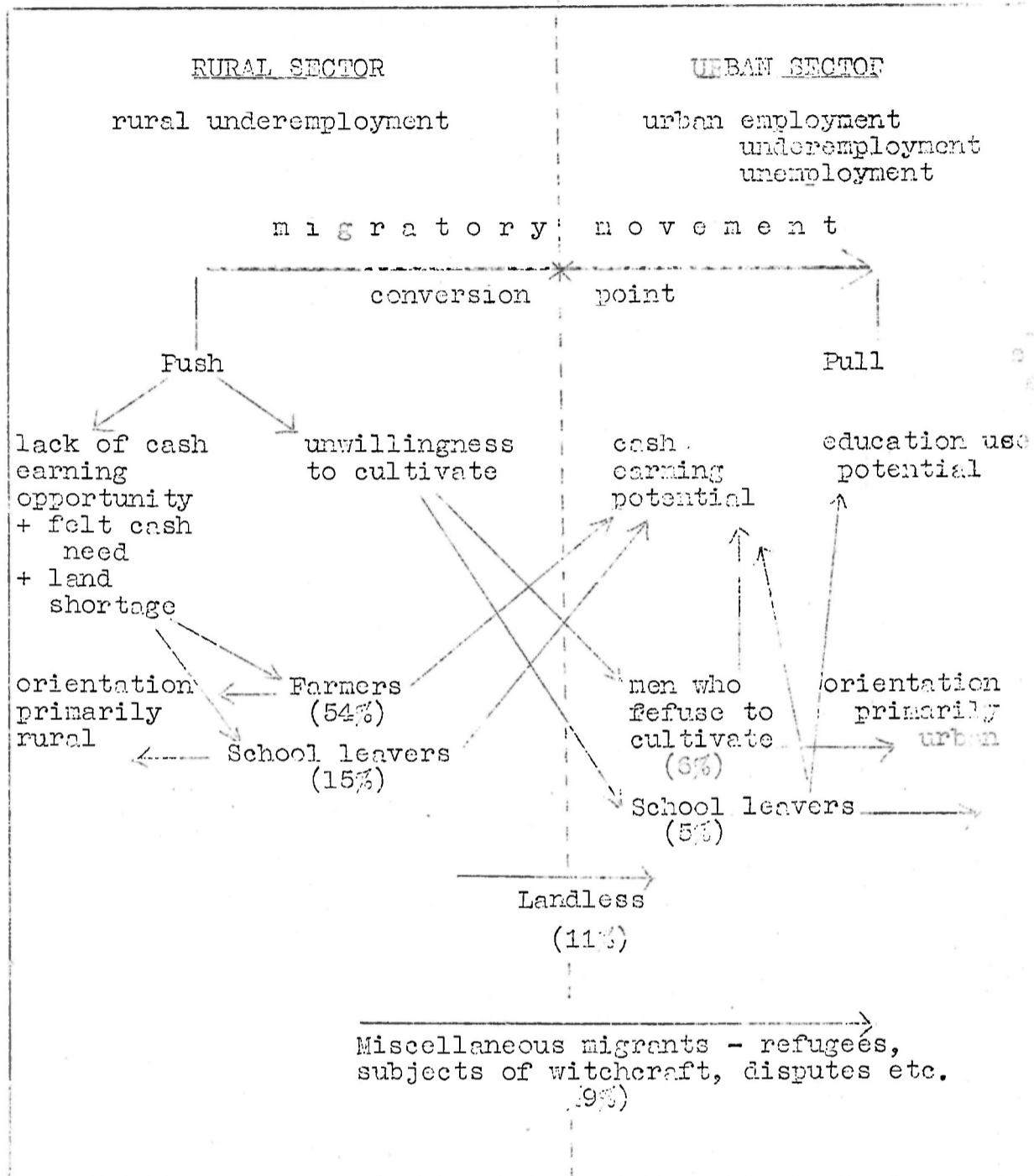

The movement of labour between town and country operates in both directions, but the diagram here is only concerned with the rural-urban movement, to illustrate both the categories of men found in the survey, and the pressure or attractions which work on them. The percentages given in the diagram are taken from the proportions of men in each group found in Kampala and Jinja together. These groups were classified on the basis of the explanations given by the men of how they came to leave home, or why they stayed on in town after leaving school, together with their experience or lack of experience of farming. From this it seemed that there were three main groups coming to the town; a small group who made a specifically urban choice of life, a substantial group whose first choice lay in a rural way of life, and an intermediate group.

The farmers were all men with experience of agriculture (though in some cases this experience was rather limited) who had rejected farming temporarily as a source of adequate income in the hope of finding higher rewards in the town. They were men who thought of themselves primarily as farmers who were being denied opportunities in their homes areas, but they had

no hostility to agriculture as such, and would have preferred to have stayed at home if their returns had been greater. It was common for men in this group to be thinking in terms of working towards savings for rural investment on their return.

In contrast to this, the largest single group, there was a small group comprising 6% of the total who were actively hostile to agriculture. There were two Baganda in this group, and a mixture of men from other tribes, who seemed to have little in common but their dislike of farming. This was expressed either in physical terms by men who had spent some years as farmers, and who said the life was too hard for them, or by boys who had not cultivated and did not want to start, because it was too hard or they did not know how. There may well have been additional work on these men, but in all cases there was a strong negative attitude to agriculture which, however, had no reference either to the educational level of the man concerned, nor to the status of agriculture as an occupation. These men were not concerned with looking for high status jobs in town, but, having rejected one form of living they had then to find another.

There were two distinct groups of school leavers (although some school leavers were to be found in other groups). The smaller group of 5%, half of whom were Baganda, had made a deliberate choice of an urban way of life, and seemed to fit into the stereotype of the boy who leaves school with aspirations higher than his qualifications. They all had Junior Secondary Leaving Certificates or post Junior Secondary education and were therefore among the most highly educated in the two groups, but their ambitions were not unreasonably high. What they wanted was a 'good life' and for this they had to have urban jobs which would bring them regular income and utilise their capacities to the full. They were only hostile to agriculture to the extent that they felt they could do better even in unskilled urban work than they could in the village, and those who started with high aspirations usually readjusted them to a more realistic level after some experience of unemployment.

The rather larger group of 15% were also school leavers, but they were not concerned with making use of their education. They had no experience of agriculture except from helping relatives in the holidays, but their orientation was primarily rural, in that they had chosen to look for work as a temporary expedient resulting from inadequate opportunities at home, and it was their perception of these opportunities that largely governed their decision to leave home. This group included boys who had not yet been allotted land, and those who had no source of income at home, because they had no cash crops, or could not cultivate on their own account. They differed from the farmers in that they had not had experience of trying to make a living at home since leaving school.

The small proportion of those who scorn agriculture on educational grounds is at variance with the opinion prevalent in Uganda that unemployment is largely due to school leavers seeking white collar work for which they are not qualified, and regarding agriculture as an inferior occupation. The majority were looking for any kind of unskilled work, setting their ambition no higher than manual work or such jobs as office boy, emphasising that their level of education gave them no greater expectations than this in a time of severe competition for jobs. A study of Nigerian school leavers shows very much the same attitudes. "It is noteworthy that these school leavers are not opposed to farming per se. The determining factor in their attitudes towards farming is whether it is in

the traditional or modern mode, the former being considered highly desirable by only 25.4% and the latter by a much larger 67.3%. These young men may be enticed back to the land if the conditions of work and income are favourable. Thus far from being blindly and stubbornly committed to lofty, unobtainable occupational goals, these school leavers evidence much realism and flexibility in setting their occupational goals and adjusting them to conditions." (McQueen 1965) In Uganda the primary factor determining attitudes to agriculture lies in the income to be derived from it, and where it is evident that a reasonable living can be made from farming, the great majority would prefer to cultivate rather than migrate to the towns.

There remain two intermediate groups who do not make their choices in the same context as either the farmers or the school leavers; the first of these are those classified as landless. One of the chief disadvantages of surveying men from such widely differing backgrounds lies in the difficulty of evaluating the circumstances from which they have come. This is particularly so with regard to patterns of land tenure, where there are differences in traditional systems, and, because of population and other pressures, divergencies between customary and current practices. A very broad distinction in Uganda may be drawn between areas where there is adequate land for the population, and areas where there is some pressure on land. Except in Buganda the sale of land is not legally possible, but where these men came from areas where land is not plentiful they generally spoke in terms of buying selling and absolute ownership, partly in a context of de facto freehold, and partly in order to simplify language problems. It was generally accepted that in areas of pressure a man who does not receive land through his father or other close relatives needs money in order to acquire access to land, though the forms of payment and the nature of his rights vary.

In view of the youth of the groups and the numbers who had no experience of farming, it was not surprising to find that 53% had no land of their own at the time of the survey, and 40% had neither land of their own nor the use of land. Of these 40% just under half expected to be allotted land by their fathers or other relatives, or came from areas where land was plentiful. Of the remainder, several had fathers who were alive and farming, leaving a final group of 25 men with no land, no expectations of getting access to land and either no father, or a father who was not a farmer. Three of these men were refugees from Rwanda, and if these are excluded 22 men or 11% of the total might be considered strictly landless.

Three of these men were Kenyans, a Kikuyu, a Muluyia and a Jaluo all from areas of land shortage; five were from areas of Uganda outside Buganda, and were all men whose fathers were dead, and who had lost their rights to land, either by leaving the district, by their father having no land, or, in one case, by a number of brothers occupying it. The remaining 14 men were all Baganda (including 1 Rwandan brought up in Buganda) that is, almost a quarter of all the Baganda interviewed were without land, or any prospect of access to land unless they had money. In the same way as for the other Ugandans, either their fathers had no land, or it had been lost on the death of the father, or shared out among other brothers. It was therefore of great importance to these boys that they should have some income from which they could provide themselves with land, without which they could have no home and no economic security. Some of them expressed the intention of staying in town for long periods if they could get work, but their concern with purchasing rights to land was still strong. As the men

who were interviewed were not randomly selected it is not possible to judge how general this type of landlessness is among the Baganda. Where boys had lost their fathers, they might have lost the chance to have land rights purchased for them which they would otherwise have received, but if increasing numbers of Baganda School leavers living near the main urban centres additionally have no land, the chances of a chronically unemployed class of youth appearing and growing are considerable.

There remains a group of miscellaneous migrants. In this category are placed refugees and those who, though economic factors may enter into their decisions are not primarily motivated by reference either to cash earning opportunities or educational opportunities. It is obvious from much of the literature on the causes of labour migration, that migration can be made to serve different functions within different societies, but it is necessary to distinguish the phenomenon of migration from the ends it can be made to serve. Once migration has become customary from an area, men only marginally in a state of need to migrate may be drawn into the general stream, or the road to town may be used as a means of escape by men who would formerly have used other means.

In general contact of Western societies with formerly non-money economies brings about a gradual increase in the use and appreciation of cash, accompanied by a rising scale of cash needs. Whenever these cash needs cannot be satisfied by local earnings, labour will be exported either into wage earning, or into cash crop growing. In a country like Uganda where there is a great mixture of tribes, and a proportion of the labour force drawn from outside the country, both the opportunities in the home area, and the levels of felt cash need will vary considerably, but ultimately the rate of labour migration is dependent on the relation between expectations, felt cash need and local cash earning opportunity. For example an area such as Karamoja shows a very low migration rate (1.6% of male away from Karamoja in 1959) in association with low felt cash need and low cash earning opportunities. Buganda with high felt cash need and high cash earning opportunities shows a rather higher rate but is still low (4.0% of males away in 1959) Ankole is an area of relatively low cash earning opportunity with rising felt cash needs, and has a high rate of emigration, both rural-urban and rural-rural, (24.9% of males away in 1959).

Winter (1955) points out that the Baamba have little economic motive for migration as their wants can be supplied as well by income from their cash crops as from urban labour. Migration is therefore largely restricted to those who would formerly have moved to another village, for example to avoid witchcraft or family disputes or simply to find adventure. In any group of migrants therefore a certain proportion could be anticipated for whom the economic choice between the rewards of town and country is subordinate to more specific social considerations. Apart from refugees, men driven to leave home in this way are those who are least likely to want to return though they may aim at acquiring land in some other area.

In spite of the flexibility of their expectations, by seeking urban work, the unemployed men in the town have chosen a certain level at which to seek work. There is a considerable volume of rural-rural migration in Uganda either to work for cash crop farmers, or to grow cash crops where income earning opportunities in the home areas are low. The continued employment of large numbers of immigrants from outside Uganda in low paid agricultural labour or in plantation work is

associated with the unwillingness of most Uganda farmers to undertake such work. Where a farmer has land which provides him with subsistence and some cash, he needs the anticipation of a certain level of income before it will be worth his while to abandon agriculture in the hope of getting work. A few of the men who were interviewed were prepared to work as porters for other farmers, or to look for plantation work, but this was usually as a last resort after experience of unemployment.

The economic point at which rural underemployment is converted into urban unemployment therefore lies at that point at which a man's opportunities at home fall below his felt cash need to a level where expectations of urban earnings are high enough to satisfy the need.

While the causes of urban unemployment must be seen to lie within the context of the factors which operate to bring men to town, the persistence of urban unemployment is governed by the length of time men will stay in town without work and how they can survive while they are there. The periods spent in town varied considerably between the groups, and were undoubtedly affected by the timing of the survey in relation to the end of the school year, news of new factories and similar factors which affect the time at which a boy or man actually comes to look for work.

Table Four - Time Spent in Looking for Work

Tribal Group	Under 3 months	3 & under 6 months	6 mths & Under 1 year	1 and under 2 yrs	2 yrs and over	Total %
Baganda	45	21	18	5	11	100
W. Province	32	21	23	16	8	100
Other Ugandans	34	14	25	9	18	100
Foreigners	44	17	14	17	8	100
Total	39	18	21	10	12	100

Although the majority had been in the town looking for work continuously for less than 6 months, nearly a quarter of the group had been looking for more than a year. It was not always possible to get very clear estimates of time from these men, and there is probably underestimation at one end of the scale, and exaggeration at the other. It is possible that this group is biased towards those who stay longest in town as those who can return to their homes without difficulty are perhaps less likely to be found.

There seemed to be fairly limited geographical mobility among these men, partly as a result of physical limitations, partly from a refusal to consider walking as a means of long distance transport, and partly from the necessity of remaining near a food supply. The unwillingness to walk seemed to come less from an appraisal of the distances involved than from attitudes which excluded walking as a possible means of travel over long distances. Over shorter distances men were prepared to walk several miles a day in order to look for work. On the whole the Baganda and Basoga were within easiest reach of home, and though some stayed for long periods from determination to find work, others could return home in between periods of job seeking. The majority of men thought they would return home eventually if they could not find work, but

only 11% said they would give up hope of finding work and would never come back to the town.

Once a man has come to the town and has failed to find work, there are a limited number of ways in which he can survive. If he cannot find someone to provide him with food and shelter he must have income from home from the sale of crops or live-stock or from gifts, or he can resort to begging or stealing. Although little information was gained (or asked for) on the last point, data was collected on the ways in which men managed to live while they were in town. From this data it was not possible to state the relationship between increasing unemployment and increasing crime, but a man with no prospects in town, with difficulties in getting food and no money for his bus fare home is likely to be strongly motivated towards crime. A very few of the men mentioned ways in which they obtained food without paying for it, and a greater number stated that they were trying to raise their bus fares home because they did not want to become thieves, and they could not see any alternative if they stayed on in the town.

African labour in both Kampala and Jinja is housed in three main areas, municipal housing estates, company quarters or servants housing, and the many peri-urban villages. Round Kampala there is also private provision in the housing areas of Mengo where urban building restrictions do not apply. These areas are scattered in both towns, and there was a tendency for the majority of workseekers to be living in the areas nearest the factories where they were interviewed. The notable exceptions were the Baganda and Basoga living at home or with relatives in outlying villages.

Table Five - Areas of Residence

Tribal Group	Est	Qrs	Mgo	Vill w. in 5 m.	Vill 5+m.	Sleep- ing out	Other	Total %
Baganda	5	2	14	45	22	-	2	100
W. Province	32	13	26	21	8	-	-	100
Other Ugandans	23	7	15	37	15	2	5	100
Foreigners	17	13	46	25	6	3	-	100
Total	19	8	20	54	15	2	3	100

Even though the majority of the Baganda were living away from home, they were staying in the villages or Mengo rather than in company quarters or housing estates. It can be seen that only 27% of the total men were staying in this provided housing, and almost half the total were living in villages round the towns.

The available evidence on the migration of rural Africans to towns indicates that they come to towns where they have relatives or tribesmen who will support them until they become independent. "To a foreigner alone and stranded, every fellow tribesman becomes a friend, and a distant member of his own clan or lineage is greeted with the warmth of a close relative. In this way travellers who come without the certainty of a particular job, yet have the knowledge of a particular house from which they will be able to seek a job or a piece of land." (Richards 1954.) In Kampala and Jinja this situation is still general, but by no means all the men who come to town have

anyone to whom they know they can go. In some cases villagers in the peri-urban areas were more willing to take in strangers who could perform odd jobs for them, then were townsman to take in their own tribesmen. The men who came without knowing who to go to would first try to find some friend or tribesman in the town, and failing that would go from village to village, sleeping out if necessary, until they found someone who would take them in, usually in return for some services. On the whole those who were staying with relatives knew before they came that these relatives were in town, and in these cases the relatives felt obliged to take them in. The hospitality offered is not necessarily inexhaustible, but it is difficult to get rid of an unemployed relative except by paying his fare home. The obligations are strongly felt, not only with regard to food and shelter, but also to some extent with clothes, small sums of money, soap and other small articles, as well as the prevailing obligation of those with jobs to find work for their unemployed kin by using all the available informal channels of recruitment.

Table Six - Relationship to Host

	Tribal Group				Total %
	Baganda	Western Province	Other Ugandans	Foreigners	
At home	23	-	3	-	6
Brother or sister	11	24	22	17	18
Father's or mother's brother	19	11	14	8	14
Other relative	12	11	22	33	19
Total with relatives	65	46	61	58	59
Employed friend	19	37	28	28	27
Unemployed friend	-	7	4	3	3
Alone	16	7	7	11	10
Other	-	3	-	-	1
Total	100	100	100	100	100

Nearly a quarter of the Baganda and a few of the Basoga were living at home, and these tribes had the lowest proportion of men staying with non-relatives. The relatives in question were most usually a man's full brother or sister, or brothers of his parents. Other relatives included grandparents, sister's husband, parent's brother's sons, and other more distant relatives. Where men were staying with friends, these included tribesmen encountered in the town, friends from school, ex-workmates and men from other tribes. Where men were staying with unemployed friends, they had either come together to look for work, and had been given rooms in return for services, or the friend had lost his job after the unemployed man had come to stay. A relatively large proportion were not staying with anyone, and these were either younger boys who had been given rooms in return for services men who had kept their houses after losing their jobs, still having some money for rent, or men who had been allowed to build small huts on someone else's land. Five of these men who had been working had their families with them.

In the majority of cases food was provided by the person with whom the unemployed man was staying, but where men were not staying with relatives they did not always have a certain source of food, and to get one meal a day had recourse to theft, begging, casual labour, or the use of savings from home or former employment. Those staying in the villages found it easier to get food from neighbours or by casual labour than those in the towns.

To the extent that friends and relatives can offer support, a man's unemployment in town can be prolonged indefinitely. A man who has been unemployed for some time, even if he is supported by close relatives, will have dispelled the 'money illusion' and be well aware of the value of 'free' food and housing in the rural areas, but he will weigh this consideration against the lack of cash income at home, and will probably aim to stay in town for as long as he can find support. Even without relatives, men will do their best to stay in the town, but their conditions of life may well be harder, and their discouragement therefore greater. Their chief source of help lies in casual labour, either in the town or the village. Other sources of income from gifts or sales of property are important in individual cases, but do not affect the majority.

Even from casual labour income was usually small and irregular, but about half of each group had found some work. In Jinja this was most often in the form of a days work at the Nyanza Textiles factory or work in the villages, while in Kampala it was predominately work in the town. Very few men had sufficient cash to start any form of trading or self-employment, and where they had done so, they usually operated on such a small margin that the slightest set back could put them out of business. There is much more scope for casual work in Kampala than there is in Jinja, and more opportunity for small scale trading, but in both towns the most common work was either at factories, or loading or unloading lorries for shopkeepers in the town. Men working in the village earned very much smaller sums, but could often find work more frequently, especially when they were paid in food. The most regularly employed were those who worked for their landlords, but there was work for others in carry water, assisting local builders and casual cultivation. Except where there was rent to be paid, income from casual work was usually used for food. In a very few cases men were trying to accumulate money towards a bribe or their bus fare home.

It is not possible in a nonrandom study of this nature to derive more than very conclusions from the figures obtained, or to judge which categories of unemployed may have been omitted from the survey, for example through the selective distribution of tribes between industries, or the movement of short-term unemployed back to their home areas. However it seems that Uganda's employment problem does not lie primarily in the attraction exercised by the town, but in the inability of the rural areas to support their present populations at their present levels of expectation. As these expectations are likely to continue to rise, and as increasing numbers will be leaving school after seven years primary education, this position is likely to become worse in the future.

Books referred to in the text:

- Clark, Baryaruha, Rado and Van Arkadie, Minimum Wages in Uganda
EDRP 49 1964 mimeo.
- R. Devauges, Etude du Chômage à Brazzaville en 1957
Cahiers ORSTOM Sciences Humaines Vol 1 No 4
(Tome II)
- A. J. McQueen, Aspirations and problems of Nigerian School
Leavers. In Inter-African Labour Institute
Bulletin Vol XII No 1 1965
- Y. Mersadier, Quelques Aspects de Chômage à Dakar
In Notes Africaines No 97 Jan. 1963
- P.G. Powesland, History of Migration in Uganda
In Economic Development and Tribal Change
Ed. A.I. Richards Cambridge 1954
- A.I. Richards, The travel Routes and the Travellers
In Economic Development and Tribal Change
- E.H. Winter, Bwamba Economy
East African Studies No 5 1955

DR. H.P. JUNOD.

RESTITUTION AND AFRICAN PENAL CONCEPTIONS

It is necessary to point out, at the beginning, that the speaker's experience covers a part of the Bantu field in Africa, especially the Southern Bantu: Nguni, Sotho, Tsonga, Chopi, and to a lesser extent the Shona (Ndau) and the Kikuyu of Kenya.

For forty years, he laboured in Mazambique (six years) and the Africans in Transvaal Prisons for thirty years, and where he became the Organiser, and then the Director of the Penal Reform League of South Africa, for over fifteen years.

1. The Tsonga proverb goes: "Musasi wa nmandzu i kuriha": The redemption of crime is restitution".
2. Western influence through colonial rule has imposed the Western system of combating crime, which has notably failed even in Western countries: Increase in juvenile delinquency in most countries; building of larger and larger penitentiary institutions; cost of crime amounting in the U.K. to over £800 millions; in New York, it is the third amount on the budget, after education and social welfare. In spite of this, there is no progress in preventing crime in youth, and no real advance in rehabilitating sentenced prisoners. Such is the summing-up of Mr. De Seynes, on August 9, 1965, in opening the UNO Congress for the prevention of crime and the treatment of delinquents in Stockholm.
3. Police work in arresting criminals, preventing detention, detention itself, deversification of institutions, psychopathic prisons, all forms of dealing with juveniles: all this has not stopped crime, and we still go on building prisons and institutions, ignoring the fact that we have flouted the intuition of educators and of the Bantu people that "restitution is the redemption of the criminal".
4. Young African States, whose foundation is deeper than declaration of independence, must refrain from looking towards Western ways in their attempt to curb crime. They must return to restitution, or compensation. We know that demographic explosion and the necessity of urbanisation and industrialisation are creating new and spectacular changes in the very structure of Bantu Africa, and that production at a much faster pace is necessary; but with all this development, crime increases rapidly. The education of the young people in Africa has often had the direct effect of decreasing parental authority: parents are, at times, afraid of their own children. There must be a sharp turn in daily teaching in the schools.
5. There is no simple coming back to old ways. A flour mill cannot be moved by an empty river. There is no coming back either to certain forms of brutality: cutting hands, or ears; harsh and brutal corporal punishment. But there is an urgent need to come back to restitution. Criminality is a disease of modern society, because society itself is criminogenous.
6. Restitution is restitution. Flogging, legal killing, imprisonment, is not restitution. What is needed is restitution in kind through an overhauled penal system, in which institutions become productive. In English-speaking countries, one always hears of correction and the word is a good one. But the program of correction is largely inadequate, if there is no material restitution, because restitution is based on the fundamental moral nature of man, even if this has disappeared in the hardened criminal or the gangster of "Murder Inc".

PROPOSAL FOR THE CREATION OF NATIONAL FUNDS FOR
RESTITUTION BY CRIMINALS TO THEIR VICTIMS, ON THE
LINES OF AFRICAN (BANTU) PENAL CONCEPTIONS

We have shown that the methods of combating crime in Western countries has been, on the whole, a failure. We have pleaded for a return in Bantu Africa to the Penal conception of "restitution as the true remedy for crime." But it is not much use to present a theory on this grave subject. We are convinced that, in view of the increase in juvenile delinquency and adult crime, a means must be found to counteract criminal activities of all sorts by practical means, and for long years we have pleaded for the establishment of National Insurance Funds against crime. We are not actuaries, and therefore cannot provide the full technical details of such an enterprise, but we suggest the following lines of approach:

1. Prisons, Penitentiary Institutions, Juvenile Houses of Arrest and Detention, etc, have always been an important item of Government expenditure. We contend that this need not be, if penal policy is planned on other lines of institutional labour.

- (i) Firstly, for the vast majority of detained persons, there is no need of the heavy maximum-security measures generally imposed by the presence of violent, dangerous and even apparently irretrievable cases. Even in those cases, and the few maximum-security institutions needed for them, labour in prison can be turned into productive channels.
- (ii) Secondly, whatever may be the type of the prisoner, he remains a man with a human soul, even if this appears unbelievable. An experience of forty years has been entirely convincing to us on that point. Law and penal laws especially are static; the individual man is not. Institutions have to establish a routine; but routine and discipline, fundamental as they are, can be deadly to change in the individual. Restitution is a lever which can be set to work in almost any individual, corrupt as he may have been, if proper means are set-up also to develop it as an institutional policy. And then, restitution opens to the institutional staff an altogether different atmosphere of work and daily necessary routine. It is a dynamic force which can make of a "cold stone jug" -as was called a Central Prison in the inmates slang - a clean jug of living water.
- (iii) Thirdly, a program of institutional labour can be developed, which alters the very nature of imprisonment in certain of its features. This will be developed in our third paper.
- (iv) For such a plan, we think that it is necessary to consider crime as a social disease, which needs social ways of counteracting it, not only in the culprit, but for the welfare of his victims. We propose the establishment of National Insurance Funds, which will be alimented mainly by the product of labour inside prisons and institutions. Prisons rightly conceived can be productive (see next paper) No person injured by a criminal would normally accept to be helped by direct restitution from the criminal. But the impersonal State can be the means of indirect compensation.

2. We insist upon the fact that Emerging Bantu Africa does not need to copy the Western World in its failures. Restitution is an African living concept, which can be used to spectacular effect if it is made the center of penal and penitentiary policy.

CONSIDERATIONS ON THE FUTURE PENAL AND PRISON POLICY IN
SOCIAL ACTION AGAINST CRIME WITHIN BANTU AFRICA

An up-to-date penal and prison policy for Emerging Africa must discard Western ways of dealing with crime. This is no pious or wishful thinking. It is quite possible to develop an African policy in this important field of social action. We cannot cover all aspects of what has grown in our mind in that respect. But the main points which may be emphasized are the following:

1. Except in extraordinary conditions, Short-Term Imprisonment should be abolished. The IPPC, the International Penal and Prison Commission which did excellent work in this field, defined "short-term sentences" as imprisonment for three months or less. These sentences cannot be educative; they are often served in improper buildings; for many delinquents, they are the first contact with penal law and they destroy the salutary fear of imprisonment; they decrease personal dignity; the family is struck more heavily than the culprit; on release, the short-term prisoner has great difficulty in reclassing himself socially; he becomes often a recidivist. -Passed in lieu of a small fine, they are repugnant because they imprison not crime, but poverty. Petty-offenders should be treated outside prisons, and enabled to retribute, to repair the damage done, by provided employment and supervised follow-up. Short-term imprisonment is often the door open to a career of crime.
2. For all other offenders, prison treatment must perforce continue. But all prisons should be turned into productive institutions, where authentic and up-lifting labour is performed. For that purpose, the first step is to diversify prisons into various productive channels: factories of all kinds, work-shops for specialized labour, agricultural undertakings, etc. In order to do so, a national approach must be made to Trade-Unions, so that they firstly admit that certain lines of national production are ear-marked for prison labour, and then supervise this labour so as to bring it within the rules they have imposed for such labour in the outside world. Once Trade-Union rules are accepted in prison labour, and proper equipment of prison factories is available, the full programm of labour apprenticeship and full qualifications becomes possible, and it can be as diversified as outside labour. On a State-wide tour of USA Institutions, in 1955, we have seen astonishing developments in that respect. The most striking was an Institution for juvenile-adults which went as high as training able inmates right up to handling, and expert handling at that, of IBM machines. -There was no lack of employment on release of such individuals... This cannot be done in Africa at present, but nothing is impossible in the future, and we speak of the future. -There is great scope for agricultural development in Bantu Africa, and penal institutions could easily be turned into profitable undertakings.
3. But then, the profits of such institutions should be treated in such a way that they fulfil a three-fold purpose: (i) they must firstly assure that the administration costs are met; (ii) they then must help to provide some means of living for the family of the inmate, - his next-of-kin suffer more than he does, and present social help is a division of present conditions; (iii) they must be used to build-up the National Insurance Funds we have already outlined.

All this is no wishful thinking. It can be made a reality, if African States keep their eyes fixed on "restitution", as the lever of an enlightened penal policy, and the lever of rehabilitation in the offender, ~~who knows he is doing something to repair the damage done.~~

4. We have fought for the abolition of hanging in the Commonwealth for most of our life, because, while it existed, it did not only affect the United Kingdom, but many African and other territories. It is a pity that abolition only came recently, at a time when the example of England has no more the profound repercussions it would have had then.

5. For the consideration of the African States, we wish to place the following facts:

- (i) The penalty of death is the only penalty in Law which is entirely beyond the field of educational measures. What mother would ask another woman to teach her child not to do a certain thing by doing that very thing herself in front of the child? The Tsonga say: "Kutlula kamhala kuletela mwana walendzeni"- "It is the jump of the impala which teaches the young one she bears". i.e. fine words mean nothing, it is the example which counts.
- (ii) The penalty of death brings the whole community to the level of the murderer. The executioner is society itself debasing its higher calling. In the West, the executioner is despised and derided. Montaigne says "not only his hand but his soul is the slave of public convenience", but he forgets to say that the executioner is the public itself.
- (iii) The penalty of death is supposed to deter others; here is the answer of Charkes Duff: "The death penalty is intended by the State to be a deterrent of murder. In proof that it does not deter, we have an average of about 150 murders a year in England. In the USA, they have thousands.."

Of nearly 4000 murderers we had in our hands, we have yet to discover the one who thought of the consequences of his action. We now know that deterrence is a lawyer's assumption of his own reaction in the criminal; it is a psychological extrapolation. Again, it is the African conception which is the best answer to the argument of deterrence: it is the example in practice of the respect for life which enhances life as an ultimate value.
- (iv) Death is not the most painful penalty at our disposal. We have prepared hundreds for their legal death. With the superhuman forces of the spirit in man, when it is properly trained and informed, death is not the King of Fears. One can prepare oneself to it, and in 30 years, we have seen only one abnormal man fighting for his physical life in front of the gallows. - The alternative is far more painful: A life in segregation from family, friends and all kith and kin; a life with no normal sexual relations at any time; a life of really hard labour, as it would be in our conception of up-to-date prisons, where labour would be positive and productive, but certainly hard.
- (v) The idea of terrorising others by public executions obtains the reverse of what is intended, and this is universal experience. The masses are not uplifted by the sight of blood. They are debased, and sometimes brought to pathological reactions, not to mention ignominious vulgarity. -Panic is never a teacher; it unhinges the mind of man and masses.
- (vi) Emperor Justinian closed administrative posts to member of the Christian Church "because their laws prohibit them the use of the sword against criminals condemned to death". They knew their Master, executed and risen, would not pull the lever of the gallows; and his behaviour was their pattern of life.

NOTES ON THE DEATH PENALTY IN SUBSAHARIAN AFRICA, OF ENGLISH
TRADITION

It is often stated, even in responsible Western circles, that the penalty of death, in cases of deliberate and premeditated murder, is absolutely essential in Bantu Africa. We have, for thirty years, witnessed over eight hundred executions by hanging in the then Union of South Africa, and have prepared for that moment those sentenced to death. We have kept silent on this issue for fifteen years, knowing that a man concerned with the spiritual side of life is considered, quite naturally as moved by his sentiment and his feelings more than by reason, logic, or a knowledge of the Law. At the end of our life, it is thus entirely dispassionately, and on the basis of a thorough examination of social, legal, moral and spiritual issues, that we wish to present the following points to the States of Emerging Africa.

1. Africa has always been Africa, it only "emerges" in terms of Western developments. But in the very region in which we are (Tanzania), the ancestors of man have lived already nearly two million years ago. Africa has probably, in the terms of Teilhard de Chardin, seen our birth:

"With a view to forming a judgment on the basis of what we now know of the evolution of Mammals, it certainly not in America (North or South), nor in Eurasia, North of the Alps or the Himalayas- but in the very heart of Africa, that man must have emerged for the first time."

Africa has not been prominent in the evolution of modern techniques, but in the perspective of human relations, she has been, for many of us, not a pupil, but a teacher. Her human history is as old as mankind. She has therefore something to say on the penalty of death.
2. There is no uniformity about the treatment of the murderer in Bantu Africa. But, on the basis of a long participation in African Life, we see the various Bantu peoples in various stages of community development. Many of the larger units, or tribes, are segmented tribes, in which the authority of the Chief is reduced to a minimum; for example the Kikuyu. Others have developed on the basis of petty chieftainships, without any strong centralisation, as my own people, the Tsonga people of Mazambique and the Transvaal. Others again have developed a strong monarchy, often highly centralised. -In the first type of society, it is very rare to meet legal death in answer to violent crime; but the ideas which are covered by the very unsatisfactory term of witchcraft, are, often enough, bringing a collective action for the killing of the wizard. In the communities of the second type, the people do not usually resort to capital punishment, but to banishment for life. In the third type, and especially under a strong military regime like the one of Chaka, among the Zulu, the penalty of death exists, and is usually carried out by precipitating the murderer or the wizard, from the top of a high cliff of rocks -like the Tarpeian rock of ancient Rome.
3. Apart from the man accused of sorcery, there is little inclination to kill the culprit, and the idea of an executioner appointed by the State, and paid for the job, is something we never meet. Africa is eminently the land of respect and profound attachment to "vital forces". "The great thing, -says the Tsonga proverb - is life". When a man kills another, he can hardly, in African terms, be considered as normal. Something must have overpowered him- and after an examination of nearly 4000 cases of condemned men, it is difficult to dispute that point. One could have been anyone of them. The idea of a man being bewitched seems to have some roots in that feeling. When one follows the way in which a murderer, - except in Western conditions of life, - has fallen to killing his fellowman, one is amazed at the insidious instigations of the act often by intimate next-of-kin, especially women. The Law is at fault in eliminating the tool, and not the moving mind behind the hand, and the tool.

No. 359.

John D. Kesby.

THE WARANGI: MUSLIM TRADITIONALISTS,
CATHOLIC PROGRESSIVES?

The Warangi are a Bantu-speaking people living in the Kondo District of Tanzania. There are some 100,000 of them, and they form an island of relatively dense population in a dry area at the southern end of the Eastern Rift Highlands. The Kondo District and neighbouring areas show considerable ethnic complexity, since the peoples immediately neighbouring the Warangi speak languages of diverse families, and none of them Bantu.

In this whole area the Warangi stand out because, unlike their neighbours, almost all Warangi speak Swahili, and this can probably be related to their recent history of contact with coastal peoples. By 1890 the major trade (and, therefore, slave) route into the interior from Bagamoyo ran through the southern fringes of Warangi country, and the Swahili traders established a camp on the site of the present Kondo town. The more southerly Warangi therefore had considerable contact with the Swahili traders settled among them.

At that time presumably (and certainly in 1902 when German administration began) the Warangi had no central organisation which administered all the people speaking Kirangi, now were there, apparently, formalised administrative structures on a smaller scale. The only people whom the German administrators could recognize as "officials" were local "big men" who acted as war leaders for their own restricted areas. Their position seems to have been based on individual qualities (generosity, foresight, decisiveness) and could not, therefore, be automatically inherited by their descendants.

There was no question, therefore of a single courtly elite adopting the features of the newcomers (as happened in Buganda, to some extent). But the Swahili seem to have enjoyed some prestige among the Warangi, possibly based upon their possession of guns and textile clothing (The Warangi wore dressed goatskins). And this prestige led to the Warangi's starting to speak Swahili and calling themselves "Muslims."

Further, in the present century, traders from the Coast came to the eastern parts of Irangi (Warangi country), to the areas of Busi and Kinyasi, below the escarpment. By the time the first Roman Catholic missionary came (in 1910) a very high proportion of the Warangi called themselves Muslims. The first missionary settled at Kondo, but about 1935 another station was set up in the Haubi Valley. And by that time the Haubi Valley was the only part of Irangi where most of the people did not call themselves Muslims. In the Haubi Valley people still had undisguisedly Kirangi beliefs, and the Valley was surrounded by a ring of "Muslims."

But since 1935, most of the Haubi people have become Catholics, so that today the Valley is a concentration of Catholics, in the middle of a ring of Muslims. This is not to say that all Haubi people are Catholics. Some are Muslims, and, similarly, there are Catholics in areas outside the Haubi area. It is, however, important to notice that nearly all Warangi today would reckon themselves either Catholics or Muslims.

In attempting to describe the relations between these two groups, it is essential to make one proviso. What I shall say is based very largely upon inference, not upon explicit recognition of the situation by Warangi themselves. This is partly because I have not had very much explicit comment by Warangi about the situation, but partly also, I suspect, because the Warangi have not a very complex vocabulary for dealing with description of relations between groups of people (apart, that is, from the use of kinship-terms).

Two examples are useful to demonstrate this second point. On one occasion I was walking along a road, and I met an old woman. We greeted each other, and the woman asked me, as people often do, if I was a Christian. When she found out that I was, she said, "The Muslims are bad people." I asked her in what way they were 'bad'. She replied they were just bad. This is not too helpful for subtle analysis of inter-group relations. Similarly, a student at upper primary school told me that, although his father and mother were Muslims, he had become a Catholic while at school (It is a Catholic school). I asked him why he had changed. And he replied that he felt that Catholicism was the "true religion" (He was speaking English), And I got no further than this.

Reconstructing the cosmology of the Warangi (before they became Muslims or Catholics) is a hazardous, and speculative, effort. But just as today they talk about God (Mulungu), Warangi also maintain that he was accepted and named in earlier times. Then, however, they also used the word "Ijuva". This also meant the sun, but only in the special sense of symbolising "Ijuva", God. There was, and is, another, everyday word for the Sun, "Mwaasu". The older men once used "Ijuva" in current speech, though they no longer do it; while the younger men have usually heard the word, and know its meaning. But they, like the older men, now call God only "Mulungu".

Today, Warangi (certainly Catholics) say that offerings of sheep, goats and cattle that were killed were directed to God, though they were also given (at the same time) to the dead relatives of the sacrificers. The dead relatives are called "varimu" (singular: "murimu"), and one man translated the Swahili "takatifu" ("sacred") into Kirangi as "varimwi" (at the place where the ancestors are). I suspect that this tendency not to separate God and the ancestors very rigorously is an old-established view, not the result of recent Mission and Muslim influence. It is significant in this respect that the old rain ceremony at Hasu (where the sacrifices were to the ancestors and to God simultaneously) is now called in Swahili "Misa ya Mvua" (the Rain Mass). Hence, the Catholic Mass is equated with a sacrifice that certainly included the ancestors. I shall return to the subject of the Mass and the ancestors shortly.

Although God is associated with the sun, and therefore the sky, and although the ancestors are associated with God in sacrifice, I have not found any association between ancestors and the sky or sun. Ancestors are, on the other hand, associated with some clumps of trees, where sacrifices were (and I suspect still are) carried out. There might seem to be a contradiction here between the associations between ancestors and trees on the one hand and God and the Sun on the other. But this is probably not a question that would arise to Warangi themselves, since neither God nor the ancestors are rigorously localised only associated with sun and tree-groves respectively.

Most offerings to the ancestors (and God) were made by small groups of Warangi, descendants of the particular ancestors involved, but one ceremony involved the whole of the Warangi. This was the rain ceremony at Hasu, already referred to. Warangi from other areas of Irangi came to the Haubi Valley (where Hasu settlement is situated) to take part in the rain-ceremony. This could only be performed by men of the Vawombe and Vasalu clans, living at Hasu. And it took place at the beginning of the rainy season each year. It took place at a tree near Haubi Lake (The tree is now and was perhaps then, overgrown with surrounding creepers and other plants). And it was perhaps the only ceremony, or activity of any kind, in which all Warangi felt they had a part. All other activities involved smaller groups than the whole of the Warangi. This is the ceremony now called "Misa ya Mvua", "the Rain Mass", and the sacrifices (of a black female sheep and a black cow) were to the ancestors, and to God.

Contact between people and their ancestors was also shown by dreams, in which the dreamer saw one of his dead relatives. This would lead to the dreamer consulting one of the traditional medical practitioners ("mwanga". plural: "vaanga") to discover what the ancestor (or ancestors) wanted from him. Similarly, illness demanded a visit to a "mwanga". The diagnosis of illness would indicate either that the ancestors had been angered by some moral lapse of their descendants, or else that some sorcerer was putting a spell on the sufferer. The "mwanga" would then indicate the necessary action for reconciling the patient with the ancestors, or he would tackle the problem of countering the sorcerer. This would involve the use of herbal medicines. However, it is possible that the Warangi used to admit also that some illness was not related to either ancestral, anger or sorcerer's malice. Many plants are known to have healing properties, even to Warangi who are not "vaanga". And this may have been equally true 50 years ago.

Against the background of this (reconstructed) sketch of Kirangi cosmic beliefs, we can ask: What remains of them now? The Hasu rain ceremony stopped about 10 years ago. Part of the ceremony involved the burying of three gourds of water at the foot of the tree. I have been shown the place where this happened, and I examined the ground carefully to see if it had been disturbed. Apparently it had not been, recently. And it seems likely that the local people are right when they say it has stopped. A smaller ceremony, where a goat is killed is still performed (I am told) on the slopes of Irumawi, the large hill at the eastern end of the Haubi Valley. Here the people are Muslims, whereas the Hasu people stopped their ceremony when the officiants became Catholic. This raises the question of how the Catholics have accommodated to the loss of the rain-ceremony, and this is related, in its turn, to the present status of the ancestors.

Much of what I am saying here is unconfirmed suspicion, and one suspicion (partly confirmed by the testimony of some small girls) is that sacrifices of animals and beer are still made to the ancestors at tree-groves. This may apply to both Catholics and Muslims. The evidence is clearer for the predominantly Muslim area toward Irumawi (where the small rain sacrifice, of a goat, is still kept.) It seems quite likely that the Catholics have abandoned the small sacrifices to the dead, just as they have abandoned the Hasu rain ceremony. But it is important to add that the Catholics pay for Masses to be said for their dead relatives. The question arises: Have they taken the sacrifices to the ancestors, and perhaps the rain ceremony, (which is also an Ancestral sacrifice) into the Church building, and incorporated them into the Mass? I cannot answer this question at the moment

for lack of detailed information. I have a very strong feeling that they have.

It may be then that, whereas the Muslims have continued their sacrifices, in the old manner, the Catholics have incorporated theirs into the Mass. We may have here a classic "working misunderstanding" - between the Italian priests and the Warangi congregation, the sort of situation described by Mongo Beti in "Le Pauvre Christ de Bomba" (1956).

There seems to be one other development that may be a result of the shift of valuation, involved in taking sacrifices into the Mass. The word "varimu" was translated to me, by one Catholic, as "mashetani" (in Swahili). He did not associate "varimu" with benevolent ancestors but with purely malicious and capricious spirits. It may be that the category "varimu" is in process of being excluded from the Mass, to become a new body of beings, purely troublesome "mashetani" in the Swahili sense. This may result from the closer association of the dead relatives with a new building, the Church, the present focus of sacrifice.

When I first arrived in Irangi I talked to Roman Catholic Schoolmasters (who were teaching me Kirangi) about the customs of the Warangi. One of them assured me that, though there had been "vaanga" (traditional medical specialists) and that some still survived, there was not much faith in them nowadays. In the Haubi Valley, where I live, I asked a man if there were many "vaanga". Many, he said. And do people go to them for help? They do. It seems that the more school-educated Warangi would like to disown the "vaanga". While not being able to deny that they exist, they express the hope that they will die out, even asserting that they are dying out. They seem in fact to be flourishing.

A similarly ambivalent attitude occurs in the attitude of one local headmaster (also a Catholic) to sorcerers (vasave). Sorcerers are said to ride about at night on hyenas, and the Headmaster implied that he did not believe this, but he had heard that one of the veteran Italian priests had seen someone doing so. I asked the priest, and he said he had not. The point seems to be that the Headmaster partly did believe the stories of sorcerers riding hyenas, and he obscurely felt that these stories received respectability from the priest having confirmed them.

The fact that "educated" Warangi (largely Catholic) with part of themselves at least, regard the "vaanga" as not respectable may account for a comment made by Robert Gray on the Wambugwe. The Wambugwe, living near Lake Manyara speak the same language as the Warangi and are similar in other features also. Gray says (Manuscript in E.A.I.S.R. Library) that the Wambugwe say that to be a "mwanga" you must first be a sorcerer, and that all present "vaanga" have been sorcerers. This may be the case, but it does seem possible (judging from the Warangi situation) that Gray's informants may have been "educated" Wambugwe who identified sorcerers and "vaanga" as both on the "dark" side (as they are, from the 'educated' viewpoint).

Many features of belief do seem, then, to have survived the last 50 years, and it is fair to say, apparently, that the basic scheme of Kirangi cosmology has remained unbroken. Men live largely in a "profane" area over against a "sacred" one, where are the ancestors and God. For Muslims, Catholics and traditional Warangi this is much the same. But there has been an important revaluation for the Catholics, affecting the position of priests.

In contacts between Warangi there are no marked signs of deference at any time, no bowing or kneeling to other people. In this, they contrast with people who hold the "premise of inequality", such as the Baganda. But there is one exception to this - the treatment of priests. On one occasion in November, 1964, an Wragi priest came for a visit to his home-settlement in Haubi (The priest works in Dodoma). When he arrived his father and his mother kissed his hand. One of the elderly female relatives. (his father's sister's daughter, but older than the priest) wanted to kiss his feet, but he did not let her. This remarkable behaviour can only be accounted for by assuming that the priests occupy a newly established niche in the society. Traditionally, there were no fulltime professional priests. Sacrifices were performed by people who were farmers just like their neighbours. This new, and unique, position of the priests can perhaps be described by saying they occupy an intermediate position between men and God, being closer to God than other men, and yet still not God nor the ancestors. This separateness is further emphasised by the fact that they do not marry, and hence are not involved in the "profane" society, of which marriage bonds are essential features. Hence, within a basically unaltered scheme of values, a new category of people has been defined, adding to (but not contradicting) the older scheme.

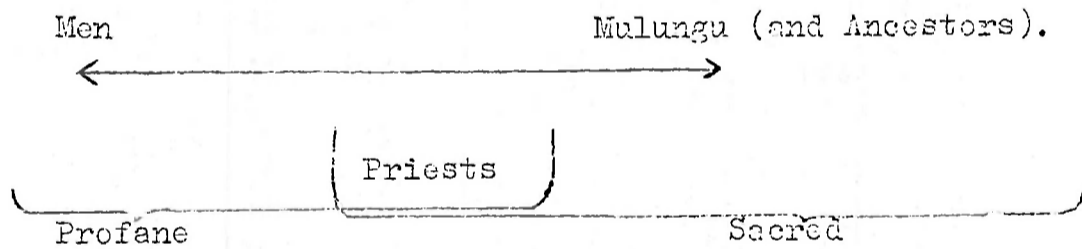

Despite great similarities, Catholics and Muslims differ in some details of behaviour. Catholics attend Mass on Sundays and Festival Days, Muslims attend the mosques on Fridays and special occasions (Though, in fact very few in Haubi do so. More occasionally in Kondoa town, one sees a man prostrating himself at the time of evening prayer. But I have never seen anyone observe any of the five times of prayer in the day apart from these occasional evening instances. Certainly, I have never seen any public observance of times of prayer among Muslims in the Haubi area.

Some Catholics Muslims do not eat pork, but neither do the vast majority of Catholics. Some Catholics have obtained pigs from the Mission, but pork is a new kind of meat to Wragi. Whereas Muslims could make a point of saying they do not eat pork, they drink beer without any comment. In Haubi Rules about alcohol apply to them no more than to the Catholics.

There are numerous divorces among the Muslims outside Haubi and separations (not divorces) occur among Catholics. There are examples of Muslims (men) marrying Catholics.

Also, Catholics are monogamous, but so are Muslims in the Haubi area. Indeed, the people were monogamous there when the Mission was established, some 30 years ago. I think this was, and is, related to the lack of land, making an additional wife a useless asset. It seems that on the new frontier of settlement, where there is no limit to available land, polygyny occurs. But I do not know how this affects Muslims or Catholics.

Kesby

One of the Italian priests said that the Muslims are just like pagans. And it is perhaps fair to say that being a Muslim in practice involves little change from older habits while being a Catholic involves more. As a postscript to this section, it is worth adding that some Catholics, as well as Muslims, wear the Kanzu and the embroidered skulleap, that is, these are not confined to Muslims.

Prior to 1963 there was a Paramount Chief over the Warangi, and he had considerable control over the appointment of sub-chiefs (majumbe) and Village headmen (wanangwa). He lived at Kolo, and he was a Muslim. A number of the subchiefs he appointed were members of his family, other were retainers of his. Conspicuously, also, the appointed headmen at Haubi was a Muslim, in a dominantly Catholic area.

From 1950 onward, there were a series of difficulties between the District Administration and the Haubi people. These centred upon demands by the Haubi leaders for a halt in agricultural improvement schemes, and on demands for the dismissal of the Paramount Chief at Kolo. It appears that a group of Haubi people (largely Catholics) wanted to displace the (to them) "foreign" chief at Kolo, and to rid Haubi of his appointed officials. This is related to the fact that Haubi people regard themselves as the Warangi par excellence. They live in the place where the Warangi first settled, they live where the Rain Ceremony was held. It was probably this sense of Haubi superiority that kept Haubi as a pagan island in the period when other areas were becoming Muslim. Later, the Haubi people showed their separateness by becoming Catholics. They then opposed the local government in the form of a "foreign" chief, at Kolo.

In 1956, the Haubi leaders carried their opposition to the local government further by founding a TANU branch, dedicated to removing the officials then in power. The formation of a national TANU Government in 1960, and the coming of Independence in 1961 allowed the removal of some officials in Irangi, and their replacement by TANU members. In 1963 the Chief was removed, as a result of a national decision to remove chiefs everywhere in Tanganyika. In 1964 the office of Village Executive Officer replaced that of "mwanangwa" (Village Headman) in the Haubi area. For Haubi itself the headman (a Muslim) was replaced by a veteran TANU official (a Catholic). Within the Haubi context, the TANU victory, which was also a Haubi victory, was, it seems, locally regarded as a Catholic victory. One old man, a Catholic, said to me: "Our King is Julius Nyerere and he lives at Rome. Perhaps sometimes he lives at Dar-es-Salaam".

This account of the struggle between the Kolo and Haubi factions seems to indicate that Muslims and Catholics form mutually opposed factions, dividing Irangi between them. It is important to stress that this is not so. In one settlement at Haubi two kinsmen, one a Catholic, one a Muslim, herd their cattle together. I have already referred to marriages between Catholics and Muslims. Kinship bonds cut across the Muslim-Catholic division. And Haubi Muslims were on the Haubi side in the opposition to the Kolo faction (which was Muslim). It appears clear that the loyalties to the people of one's locality (and this means to kinsmen who form a network throughout the locality) outweigh any loyalty to Muslim or Catholic factions. Indeed there are no recognisable Muslim and Catholic factions. The Kolo faction was a party in power. It was opposed by Haubi for Haubi reasons. For Haubi reasons also, Haubi people

became Catholic. Hence the Haubi leaders were largely Catholic. But firstly they were Haubi. Most people are today, probably, Catholic or Muslim because their fathers were Catholic or Muslim.

Nevertheless, there is something in the priest's saying: Muslims are just like pagans. The self-consciously "progressive" people are concentrated in the leadership of the Catholics (This is true at least for the Haubi area). But this does not mean there are no "progressives" among the Muslims. For instance, one of the Veterinary Field Assistants is a Muslim. He was educated, however, in Catholic Schools. This association between "progress", schooling and the Catholics is very close since the educational facilities of the District have been almost entirely established by the Catholic Mission. It is perhaps significant that I have heard one old man refer to the Mission at Haubi by the one word "maendeleo" (Swahili for "progress").

In Haubi, the recent take-over of official positions by TANU personnel has resulted in the largely Catholic "opposition" taking over from a previously Muslim "government". This may have increased Catholic prestige in the Haubi area. Certainly there are examples of people going across to the Catholics there. Two schoolboys, in Catholic schools, and from Muslim households, have become Catholics. And so has an old man, one of the few remaining overt pagans, and associated hitherto with the smaller rain-ceremony on Irumawi.

Perhaps one could sum up the situation between Catholics and Muslims in a diagram:-

<u>Catholics</u>	<u>Muslims</u>
Haubi	Kolo
Haubi	Rest of Irangi
Progress	Non-progress.

But this diagram gives an incomplete picture, since it ignores the fact that most people are not aware of any factional cleavage between Muslims as such and Catholics as such. There is no Catholic party or Muslim party, for either the whole of Irangi or each region of it. The Haubi-Kolo conflict was fought between factions that seem to have been a small part of the total populations. Most people are what their fathers were without feeling that they are members of a faction just by being Catholic or Muslim. (But see Note 2 at end) Factions-politics is on a smaller scale than that, all over Irangi. At the same time there is an association between Catholics and progress. Being Muslim is a way of staying Kirangi. It involves less change than becoming Catholic. And there is an association between Catholics, "progress" and Haubi.

Without figures to back it, I feel I am still safe in saying that Haubi has the highest education rate of any part of Irangi. This is connected with the large number of Catholics there, and the educational facilities available there (Up to Standard VI). Within a year it is planned to reach Standard VIII. Hence today, the Haubi people can claim superiority on the basis of their educational status. First, they stayed pagan, because they were the "top" Warangi. Then they became Catholics, separating themselves from the neighbours. Then they acquired higher educational standards, and they challenged the then "government" of Irangi. Now they can still assert their "top" position, pointing to their educational position.

And, indeed, other Warangi still do talk of Haubi as the centre of the country, the place where people speak Kirangi best. I have not mentioned in this account any doctrinal differences between Catholics and Muslims. For instance, there has been no attempt to discuss the relevance of the Incarnation to Catholics and Muslims respectively. The reason for this is that it does not seem to be a relevant topic to the Warangi situation. Certainly the Incarnation has never been raised in conversation with me. The essential feature of the relations between Catholics and Muslims in relations between mutually exclusive groups which are defined in purely Kirangi terms, that is, locality and kinship terms. To say in Kirangi "I am a Catholic," is not a Christian credal statement. It may be seen more as a statement meaning "Haubi people are top people".

Note 1. One schoolboy, about to go to Secondary School in Dar-es-Salaam, assured me that in his home-area (Gongo, where the people are mostly Muslim) no-one drinks beer, not even at weddings. I've not been to the area to check this, but I doubt if it is true.

Note 2 I asked a Catholic from one settlement (Isengi) why one man (the only Muslim householder in an otherwise Catholic settlement) was a Muslim. The Catholic replied: Shauri rachwe (That's his business). This fits in with the implicit Kirangi assumption that a man is master of affairs within his own house and shamba.

University Social Science Council - Conference January 1966
held at Makerere University College, Kampala, Uganda

A.Molnos
c/o EAISR
P.O.Box 16022
Kampala

D R A F T :

Paper no.365

AN ATTEMPT TO MEASURE ATTITUDES
RELATED TO ECONOMIC AND SOCIAL DEVELOPMENT¹⁾
(A discussion of its methodology and some preliminary results)

by
A.Molnos

- I. Introduction
- II. Method
 - 1. Content of the test
 - 2. Sample
 - 3. Administration of the test
 - 4. Methodological problems
 - a) The effectiveness of the instructions
 - b) Formulation of the incomplete sentences
 - c) The language problem
 - d) Selecting the sentences and fixing their sequences for each section
 - e) Interpretation of the results
 - f) Techniques of fixing code-categories
 - g) Scaling of attitudes
- III. Some preliminary results
 - 1. Subject: money management
 - 2. Subject: Urban life
 - 3. Subject: Family planning
- IV. Conclusions

1) A revised version of this paper will be part of the East African Institute of Social Research Conference Papers January 1966.

I. INTRODUCTION

The test which is discussed here is a part of a study on the "Position and role of ~~women~~ in the economic and social development of East Africa".

Most of the items included in the test are directly related to economic and social development. The main purpose is to see whether and under which conditions the respondents' attitudes are keeping with the values necessary for development. A major goal is to see to which extent sex - among all other factors - has a significant bearing on the different types of attitudes.

A sample of Primary and Secondary schools in rural and urban areas of Kenya, Tanzania and Uganda was chosen in order to collect a great number of cases within the relatively short time available for the study.²⁾ In order to find out the attitude differences between female and male respondents, girls and boys were included in equal numbers in the sample.

Beside the necessity of a big sample covering a wide range of social, occupational and economic positions, types and levels of education, and religious and ethnic groups among both sexes, my concern was to collect spontaneous individual responses with the possibility to transform them in the process of evaluation into quantitative categories. These and other considerations led me to develop this test.

In view of the great interest among some colleagues in methodological problems of social research in East Africa I would like to describe the main difficulties involved in this test. The evaluation itself is still in the initial phase. The few preliminary results which can be given are not conclusive and are intended first of all to illustrate methodological aspects of the work.

II. METHOD

1. Content of the test

The test has been designed to measure some attitudes of the young educated generation with respect to the following items of social and economic development:

- Role of the sexes in family and social life
- Marriage
- Family planning
- Health
- Nutrition
- Rural and urban life
- Farming and cattle
- Work
- Money
- Traditional values

The responses are expected to give also some indirect indications of the facts underlying the respondents' views and

- 1) The study is sponsored by the IFO-Institute for Economic Research, Munich, and financed by the Fritz Thyssen-Foundation.
- 2) Here I have to express my gratitude to H.Naylor who helped me in the decision to base the study on a wide sample, to R.E.S.Tanner for calling my attention to the usefulness of schools as a source of information and to H.C.A.Somerset who gave me valuable advices for sampling.

attitudes.

The test consists of 93 incomplete sentences covering the above topics.¹⁾ Methodologically one of the essential features of the test is the use of two or four slightly differing variants of the same sentence (parallel sentences). The comparison of the answers to parallel sentences facilitates several types of control in the evaluation (isolation of semantic and other biases) and also renders the investigation of attitude trends within sub-groups easier.

The whole set of sentences is divided into four sections. Each respondent received one section only. The division into sections was necessary for several reasons, not only because of the great number of sentences. As the pilot study showed the answers to parallel sentences given by the same respondent tended to be 'constructed' in a logical way rather than to be spontaneous reactions to each sentence (cfr. 4.d). The control of a whole class working on the test would have become a hopeless task and a source of unpleasant tension if the respondents would have recognized the possibility of copying from each other. This was easily avoided by distributing the four sections of the questionnaire in alternative order in each class. Each respondent was surrounded by neighbours filling in questionnaires different from his own. Furthermore the alternative distribution assures a reliable sample split in four groups within each school class, offering the basis for a methodological check (comparative evaluation of parallel sentences).

The sentences covering each topic were first constructed on the basis of existing information and some theoretical criteria. Semantic and content variations were introduced by formulating parallel sentences. The language problem was dealt with by presenting the test in a bilingual form and letting the respondents choose the language which they found easier to think and write in.

The first pilot study (with sentences in English and Luganda) was carried out in May 1965 in two classes of the Secondary Girls' School 'Christ the King' in Kalisizo township (Buddu county, Masaka district, Uganda). The second was conducted among 400 respondents in June 1965 in seven Junior and Senior Secondary schools in Masaka district. On the basis of these pilot studies corrections were made in the test by eliminating some sentences and reformulating others as well as by improving the questions on the personal data at the beginning of each section.

2. Sample

The resulting definitive form of the test (with sentences in English and Kiswahili) was carried out in September-October 1965 with pupils from the last two years of Primary and the first two years of Secondary classes (Standard 7,8; Form 1,2) in 32 Tanzanian and Kenyan schools. Two classes of different levels (exceptionally only one or also three) were tested in each school. Up to now 1962 respondents have been tested.²⁾

- 1) Incomplete sentences are commonly used in individual psychology especially for testing 'deep' personality factors. To my knowledge no standardized test of incomplete sentences has yet been developed for measuring frequencies of attitudes in a representative sample.
- 2) Including the testing in Buganda - planned for February 1966 -, the study will cover over 3000 cases (without the pilot study)

In the construction of the sample the following characteristics were taken into consideration:

- Rural schools (Tanzania: Geita, Kwimba, Mwanza, Ukerewe; Kenya: South Nyanza, Central Nyanza)
- Urban schools (Mwanza, Nairobi, Kisumu)

- day schools
- boarding schools

- boys' schools
- girls' schools
- co-educational schools

- catholic schools
- protestant schools
- moslem schools
- mixed schools

- Government aided schools
- private schools

The selection of the different classes and types of schools provides the age and sex distribution as well as variation on respondents' religion, wealth and social status. Obviously the sample rules out children from very poor homes because their parents can not afford economically to send them to school.

This is a sample of schools and not of individuals. The different types of schools chosen do not reflect an exactly proportional distribution of the characteristics of all Tanzanian and Kenyan schools. It is hoped, however, that no relevant features were left out and that cross-correlations will allow the elimination of some irregularities of the sample, as well as the isolation of the influence exercised by different educational policies from other factors underlying respondents' attitudes. However, our primary interest is not to investigate schools or educational policies. A school sample was chosen for technical reasons. Among these are the facility of collecting a great number of cases in a short time, of keeping interview conditions uniform, and of controlling and standardizing the research tool itself.

We are not interested in the answers of our respondents because they are school children. 'School children' is a misleading term. Their ages range from 12 to 22. The years 15, 16, 17 are represented by 70% of the sample. African school children in these age groups are no more children. Unlike the relatively protected situation of children in countries with high per capita income and division of labour most of these children face the same problems as their adult relatives. Living in overcrowded rooms in the towns, working in the households and farms or earning money in their free time, suffering from lack of food and clothing there is generally no aspect of human life that remains hidden from them. In a part of the world where the traditional marriage age is 5 to 10 years lower than in Western societies, where the female child is supposed to work in the household from its earliest age, nursing her younger sisters and brothers, assisting her mother in almost every work, girls over 14 are more like grown up women than children. Many of the boys have to interrupt their studies for years in order to earn money for school fees and return to school after a hard life experience.

During a very lively discussion in a secondary school a boy - about 18 years old, with the appearance of a big pater familias - stood up and asked me: "Why do you put to us these questions

which concern adults? We have no experience of life." I looked at his face and did not answer. He hardly could keep his serious countenance. I looked at the other faces in the overcrowded classroom. Finally my answer "Do you honestly believe..." was interrupted by an outburst of resounding laughters. His question was the best joke of the discussion.

Nor can it be argued that in the school situation only 'learned answers' are given. The type of sentences respondents were asked to complete did not leave much scope to do so by means of knowledge acquired in school. They were dealing with problems of daily life. If school influences affect the answers the same influences will also be operative in their attitudes to outside life.

In testing school girls and boys our aim is to deal with a sample representing the young educated generation of several social strata who in a few years time will play a most important part in their country's economic and social development.

3. Administration of the test

In each area the schools were selected with the kind help of central and local authorities (Ministry of Education, Regional Commissioner, Regional Educational Officer, etc.). They also provided introductions to headmasters and timed the visiting programme.

The test took about one and half hour in each class, including the preliminary instructions and a discussion with the respondents afterwards.

The pupils were asked to complete the sentences in such a way that they would make sense and express ideas which they believed to be true. They were advised not to finish the sentences with only one word but to write possibly longer sentences. Furthermore their attention was called to both languages - English and Kiswahili. Between them they could choose freely the main task being to write sensible and true sentences and not to prove their English knowledge. It was also stressed that the information obtained would be evaluated for research purposes. Their sentences would not be given to their teachers or headmaster. Two examples of incomplete sentences ("The sky is...", "Yesterday when I went home...") were finally practised with the class in order to demonstrate that even very simple incomplete sentences could be finished in many different individual ways all of which could be correct and true. Then the four different sections of the questionnaire were distributed in alternative succession along the rows. During the work children having some difficulties (understanding of words, spelling) were helped individually. No help whatsoever was given as to the ideas necessary to complete the sentences.

After collecting the completed questionnaires a thorough explanation of the aims of the test was given. An attempt was also made to explain in simple words and examples the method to be used in the evaluation and interpretation of the answers. Finally a discussion was opened. The questions and doubts raised by the children were often not very different from those which research colleagues use to formulate about this study. The liveliness of the discussion varied considerably between different types of schools. The skill to argue in a collective discussion was obviously related to the educational level. But the interest in the new kind of task they had been asked to perform and in the intentions involved in this research seemed to me to depend more on the value system in which they were educated. In certain schools individual and critical thinking is encouraged, whereas in others a more passive and subdued attitude, and obedience to the authority is cultivated as an ideal for educated youth.

nating to accept that the main concern of the parents - as seen by the respondents - is about losing their son, while in the case of the daughter (parallel sentence in the same pilot study: "Parents who have a daughter going to school are always fearing that...") quite different problems arise. But the fact is that the verb 'going' led to associations with the way to school rather than the school situation itself. On the other hand the sentence with 'daughter' led to almost no 'accident'- answers for the simple reason that the associative link 'going-school way' was overlapped by the real situation of the respondents who were not 'going' to the school every day but living in it (girls in a boarding school - first pilot test, May 1965).

Another example: "A man goes to stay in town because...". One easily understands that "... he is looking for a job"(34%) or "... he wants to earn money"(8%) or "... he prefers town life" (13%). But what does it mean when he goes to stay in town because "... the job is far away from his home"(12%)? Is it a meaningless answer, a misunderstanding or what? Correlations with the areas of the schools show that these answers are frequently given by children living in the periphery of a town. The answers are reflecting the probably frequent case of a town worker who in a first period of his employment keeps on living with his family in the suburban area and then decides to settle down near the office or workshop.

'Lack of water' was mentioned in 10% of the answers to the sentence "The difficulties of people living in a village are that...". Considering the wide spread of answers to this rather 'open' sentence, the percentage makes one feel suspicious. As a matter of fact half the sample was tested at the end of a very dry season in Sukumaland ...

All these cases show how circumspect the interpretation has to be. But they also indicate that to a great extent the responses reflect not only respondents' views and attitudes but also the realities in which they live.

f) Techniques of fixing code-categories

The answers of 1962 respondents are covering the 93 incomplete sentences divided into four sections: Sections I, J, K and L answered by 495, 492, 488 and 487 respondents respectively. It means that each sentence was completed by almost 500 respondents. The sentence supposed to measure the attitude to the test itself - "These sentences..." - has been completed by all respondents.

Before fixing the code-categories for the statistical analysis, the personal data of all 1962 respondents were examined. These include: school class, sex, age, religion, ethnic group (=tribe), place of birth, mother's and father's residence, and father's work.¹ Information on the schools had been collected from the headmasters by means of a short questionnaire and also appear on the individual punchcard.

In order to fix the code-categories and develop the scaling system for the evaluation of the completed sentences 100 questionnaires of each of the four types were selected at random.² The different ---

- 1) In developing the code system for religions I had the valuable help of Louise Pirouet and B. Tayler both dealing with research on religion in East Africa. J.D. Heijnen from the Dutch team working at the Nyegezi Social Research Institute, Mwanza, assisted me in the categorization of professions (= father's work).
- 2) Up to now the answers to sentences dealing with money management, urban life, family planning have been evaluated in 200 questionnaires (sections K and L) - /footnote continues next page/

types of responses to each sentence were counted and written down in separate lists for each sentence. The code categories were fixed according to the frequency of the answers. As a general rule answers with less than 4% frequency were summarized together with other analogue ones or put into a remainder category ("Other answers"). After fixing the code categories for the answers as formulated by the respondents, a second (often also a third, fourth) coding scheme on a higher level of abstraction or upon a particular point of view was developed for most of the sentences (= "over-code"). E.g. for the answers to the four parallel sentences: "A woman/man who had Shs 10/- /Shs 100/- went to buy..." three different over-codes were fixed:

- Purchasing power : right estimated
- " " overestimated
- " " underestimated
- Estimation not clear
- Frustration, unsolved problem before the purchase
- " in connection with the purchase
- No frustration expressed
- Expenditure for 'family', 'home' (not further specified)
- " " husband/wife
- " " child(ren), son, daughter
- " " parents
- " " other relatives
- " " 'friends', visitors
- " " impersonal institutions, beneficence,
- 'nation building'
- None of the above cases applies

In the case of other incomplete sentences suggesting financial decisions a further over-code was introduced in order to find out the level of economic thinking:

- Productive investment (in farming, trading, etc.)
- Commodities (personal and household)
- Consumption
- Combinations of the above categories
- None of these cases applies
- The same categories adding:
- Investment in education (=school fees)

(from page 12)

The suggestion to elaborate the coding and scaling system on the basis of a sub-sample was made by J. Gugler.

- 1) Here I have to thank my assistant J. Ibaarah-Ryamugwizi too, who for weeks has been working on this tedious task full-filling it with great exactitude. S. I. Bandic from Tanzania was in charge of the translation of the questionnaires answered in Kiswahili.
- 2) "A woman/man who received Shs 1000/- decided..."
 "A woman/man who works in Mwanza/Nairobi got her/his salary and decided..."
 "A clever woman/man borrowed money because she/he wanted to ..."
 "Some people save money because they want ..."
 "People entering a bank want ..."
 "If you want to become very rich it is necessary that..."

be carried out in order to check if increased needs for consumption and commodities among respondents from higher income families are prevailing over their ideas of productive investment whether the lower frequency of responses with 'productive investment' simply reflects the town situation where people as a matter of fact spend much more money in articles for immediate use than in the rural areas.

Differences between the sexes can be found in sub-groups. So for instance in urban Primary schools girls have higher scores than boys while in urban Secondary schools just the contrary is true. All correlations dealing with rural conditions indicate the existence of two opposite groups of female respondents: one group attaining higher, the other lower scores than the corresponding male groups (This applies to: daughters of farmers, girls living in a stable rural family, girls in rural Primary schools).

Also the correlation with the age of the respondents shows differences between the sexes. In the age group 12 to 15 girls attain higher scores than boys, over 15 girls are in two groups, one with relatively high, the other with extremely low scores for 'economic thinking'. The reason for this uneven distribution of female responses can only be found out by examining the whole sample, our sub-sample (200) being too small for further correlations.

As to the respondents' age relative to their class they were divided into three categories: 1. Respondents whose age is below the average age of their school class ('young'); 2. Respondents with average age (average); 3. Respondents who are older than the average (old). There are no striking differences among them as to the level of 'economic thinking'. The average group seems to perform somewhat better than the other two. Since the 'young' group is generally very successful in its school performance, this result seems to invalidate to a certain extent the above observation that 'economic thinking' is strongly related with general education level. If there is a contradiction then it can only be found out in the whole sample distinguishing within the 'young' group between pupils from Primary and Secondary schools. The fact, however, that the 'old' group has also low scores shows that 'economic thinking' can only partly depend on maturity and life experience. As well known the 'old' pupils generally have the lowest performances in learning.

A second scale in which responses indicating investment in education (=expenditure in school fees) were also taken in consideration shows higher scores for the 'old' group than for the others. The greater concern with 'investment in education' of these respondents who have already lost some years of education - mainly because of lack of money - is quite obvious.

Taking into consideration the real age of respondents, 'investment in education' is more frequently mentioned by boys than by girls within each age group (below 15, 15, 16, over 16). The boys' concern with education seems to be the highest at the age of 15. This probably indicates their worry about the higher costs of Secondary school which they either want to enter or

-
- 1) Although since 1963 Secondary education is free in Tanzania the chances for a Primary school leaver to enter one of the Government supported Secondary schools is extremely low, even if his school performance is good enough to entitle him or her to apply for admission. If the pupil is not selected because of insufficient notes or not admitted because of the limited number of free places, he has to go to a private Secondary school (school fees about Shs 700/- per annum plus admission fees) or interrupt his studies.

just began.

Among the girls the mentioning of 'investment in education' is most frequent in Secondary schools at the age of 16. Here again it is difficult to give an explanation before the whole sample is examined.

2. Subject: Urban life

On the whole positive attitudes to town life seem to be almost equally frequent among girls and boys. Nor is there much difference between the total of respondents in Primary and in Secondary schools.

Respondants living in towns have a much more positive attitude to urban life than those living in rural areas. But there is an opposite trend between girls and boys living in rural areas, the positive attitude to town life being much more frequent among girls than boys. The same trend - and even more striking - is observed in the comparison of the scale between daughters and sons of farmers. This result should not surprise much considering the multiple and partly heavy work the rural girl has to carry out from her earliest age and even during her school period. On the other hand school boys in rural areas are generally relieved of their habitual tasks, whether because there is no more time for it after returning from the school (e.g. cattle-keeping is a day work) or because his status as a 'school boy' is much more respected by the family.

According to headmasters this situation causes girls frequenting rural day schools to be seriously handicapped in their studies, as they are not able to carry out their home exercises for the next day.

As to the boys, positive attitudes to urban life are the most frequent among the youngest ones (age: 12 to 14), and diminish progressively in the following age groups of the sample (15, 16, 17 to 21). Girls below 15 seem also to be much more attracted by the town than the 15 and 16 years old female respondents. But the eldest group in contrast to boys of the same age is very much in favour of it. The frequency of their positive remarks is higher than that in all other age groups. This also might indicate a desire to escape from the heavy life conditions female school leavers have to expect in rural areas and to follow a completely different style of life (cfr. also above the concern with education of Secondary school girls).

3. Subject: Family planning¹⁾

Attitudes to the desirable family size seem to depend on several factors.

Generally, the higher the educational level the more frequent the positive attitude to family planning. However, apparently independent from all other factors, the highest rates in favour of the limitation of the number of children were found among those respondents whose parents live separated. Obviously these children experience the difficulties the lonely mother or father has to face providing for the needs of the children.

1) The term 'family planning' is only used in the analysis of the results. It did not appear at all in the questionnaire. The incomplete sentences were referring to a woman or man who has no children or only one child or many children or to a married couple who has three children or decided not to have many children.

This work is licensed under a
Creative Commons
Attribution – NonCommercial - NoDerivs 3.0 Licence.

To view a copy of the licence please see:
<http://creativecommons.org/licenses/by-nc-nd/3.0/>