

OCTOBER 1991
RESEARCH PAPER SEVEN

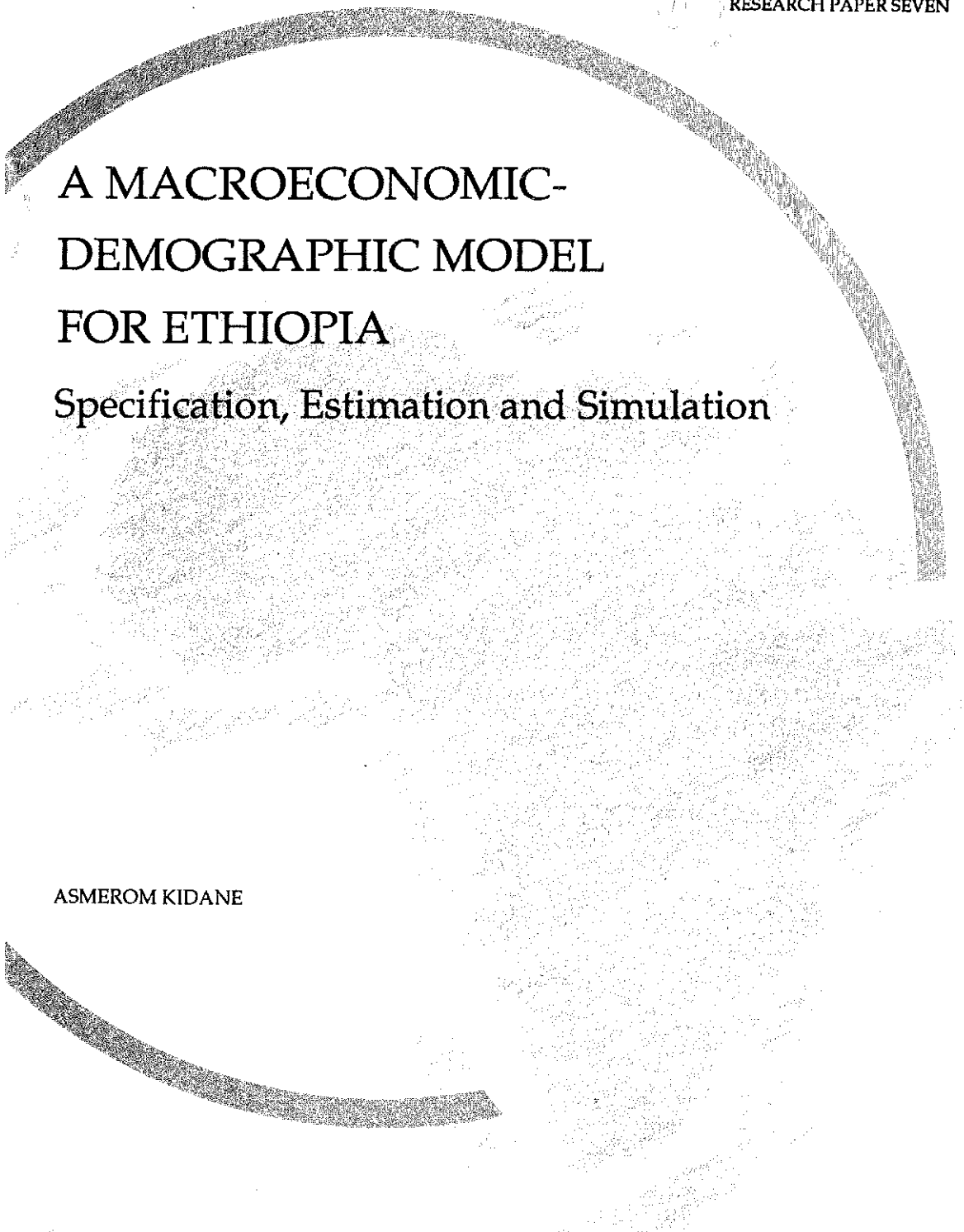

A MACROECONOMIC-
DEMOGRAPHIC MODEL
FOR ETHIOPIA
Specification, Estimation and Simulation

ASMEROM KIDANE

AFRICAN ECONOMIC RESEARCH CONSORTIUM
CONSORTIUM POUR LA RECHERCHE ECONOMIQUE EN AFRIQUE

LIBRARY
28 MAY 1992
Institute of
Development Studies

**A macroeconomic-demographic
model for Ethiopia**

Other Publications in the AERC Research Papers Series

Structural Adjustment Programmes and the Coffee Sector in Uganda by Germina Ssemogerere, Research Paper 1.

Real Interest Rates and the Mobilization of Private Savings in Africa by F. M. Mwege, S. M. Ngola and N. Mwangi, Research Paper 2.

Mobilizing Domestic Resources for Capital Formation in Ghana: The Role of Informal Financial Markets by Ernest Aryeetey and Fritz Gockel, Research Paper 3.

The Informal Financial Sector and Macroeconomic Adjustment in Malawi by C. Chipeta and M. L. C. Mkandawire, Research Paper 4.

The Effects of Non-Bank Financial Intermediaries on Demand for Money in Kenya by S. M. Ndele, Research Paper 5.

Exchange Rate Policy and Macroeconomic Performance in Ghana by C. D. Jebuni, N. K. Sowa and K.A. Tutu, Research Paper 6.

**A macroeconomic-demographic
model for Ethiopia:
Specification, estimation
and simulation**

Asmerom Kidane

*Statistics Department,
Addis Ababa University*

AERC Research Paper 7
Initiatives Publishers, Nairobi
October 1991

© African Economic Research Consortium, 1991

Published by Initiatives Publishers,
a division of Initiatives Ltd.,
P.O. Box 69313, Nairobi, Kenya,
(Tel. 744047, 744095 Fax 743995)
for the African Economic Research Consortium,
P.O. Box 47543, Nairobi, Kenya

Printed by English Press Ltd.,
P.O. Box 30127, Nairobi, Kenya

Cataloguing in Publication Data

A macroeconomic-demographic model for
Ethiopia: specification, estimation and
simulation/Asmerom Kidane.—Nairobi, Kenya,
Initiatives Publishers, Initiatives Ltd., 1991.

(African Economic Research Consortium (AERC)
Research Papers Series; no. 7)

ISBN 9966-42-030-4

Contents

List of Tables	iv
List of Figures	iv
I Introduction	1
II Description of a simplified economic-demographic model	3
III Mathematical formulation of the model	5
The economic sub-model	5
The demographic sub-model	7
IV Data sources	9
V Results and applications	10
The economic sub-model	11
The demographic sub-model	13
Simulation	13
VI Conclusion	16
Notes	17
References	18

List of tables

1. Summary statistics of selected economic-demographic variables	9
2. Regression of age-specific fertility rates	10
3. Regression of age-specific survival rates for rural and urban areas	11
4. Projected economic and demographic variables under reduced fertility schedules	15

List of figures

1. Schematic presentation of economic-demographic interaction	4
---	---

I. Introduction

The population variable was not given due attention by classical and development economists until the early 1950s. The earliest "economic demographer", Malthus, tried to show that a high rate of population growth would eventually lead to a negative marginal product of labour and that this would, in turn, lead to a high mortality rate. Malthus stated that the equilibrium between man, capital and land would be retained through what he called positive and preventive checks.

Notestein (1945) and others tried to develop the concept of demographic transition by implying that a higher level of economic development was a prerequisite for a lower rate of population growth. This relationship was also implied by Marx. As a result of this, it seems that in the process of development planning, the population variable has been treated as exogeneous—i.e. a variable that is determined outside the system and that nothing can be done to alter it.

The first attempt to depart from this was that by Coale and Hoover (1958). While these authors showed that there is a negative relationship between population growth and economic development, they also treated population as an endogenous or policy variable. In other words, they tried to show that a country can reach a higher stage of economic development if the rate of population growth is slower. The Coale and Hoover model is based on the "dependency ratio" argument, that is, a higher rate of population growth would lead to a larger percentage of younger members in the population, most of whom are dependants. The latter are mostly consumers, not producers. This would, in turn, reduce per capita saving, capital formation and eventually, investment and per capita GDP. The above assumptions were applied for India and Mexico and the results showed that the dependency ratio argument does have some relevance.

Following that pioneering work by Coale and Hoover, Enke (1974) developed a series of simulation models. He described a disaggregated economic-demographic model to study the effects of government-financed fertility reduction programmes on various indicators of development over a 30-year period. Enke's model is supply constrained since an increase in government expenditure will be at the expense of private consumption and investment. The results show that increased government expenditure on family planning services will increase almost every indicator of economic development.

The models of Coale, Hoover and Enke are simple projections based on a hypothetical situation. They do not use past observation to predict the future through regression or related models. Leff (1969) attempted to estimate the demographic determinants of saving by using cross-country data where a country was taken as a unit of observation. He applied Ordinary Least Square method on the demographic determinants of saving and found that there was a significant negative relationship between the saving rate and the proportion of dependants—both young and old.

By far the most comprehensive study on the relationship between population growth and economic development was provided by Tung (1984) for Taiwan. He developed an econometric demographic model for Taiwan and used time-series analysis to estimate his 115 equations and identities. He found that in the short run a reduced rate of population growth will bring about a higher rate of per capita income. One of the major drawbacks of Tung's model is that it did not take into account migration of people from rural to urban areas. Similar results were obtained by McIntosh (1978), Gillman (1981) and others. On the other hand, little modelling was done on economic-demographic interaction in African countries. Therefore, this author (Kidane, 1987) carried out such a study for Ethiopia and the results suggest a negative relation between per capita saving and the proportion of young (not old) dependants.

The purpose of the present study was to develop a detailed economic-demographic model for Ethiopia, study the interaction between the two, considering various demographic variables as being endogenous, and to assess the effect of changes in these demographic indicators on some economic parameters. The paper develops the economic-demographic interactions in a schematic form by identifying the direction of variable associations and then recording the various structural equations and identities. Time-series data from Ethiopia will then be used to estimate the appropriate parameters, followed by simulation under different assumptions.

II. Description of a simplified economic-demographic model

The simplified economic-demographic model and the interaction between the two is given in schematic form in Figure 1. The model is divided into two sectors—the traditional and the modern. Each sector has its own economic and demographic sub-models. The traditional sector is again subdivided into subsistence and cash-crop economies. We assume that modern-sector production will utilize capital as an input, while traditional-sector production will not. A consumption function will also be specified, even though it is not shown in the schematic presentation. In the demographic sub-model, birth rate, death rate and migration rate will have an effect on the size of the population which, in turn, will affect the labour force and consumption. Migration will be between the traditional and modern sectors, the movement being from the former to the latter. Obviously, this will have an effect on the population size of the traditional and modern sectors.

A government consumption function, along with exports and imports, will also be considered. The amount of exports will be a function of the traditional sector. This, in turn, has an effect on imports, and eventually on capital stock, labour-force participation rate, and eventually on the overall GDP.

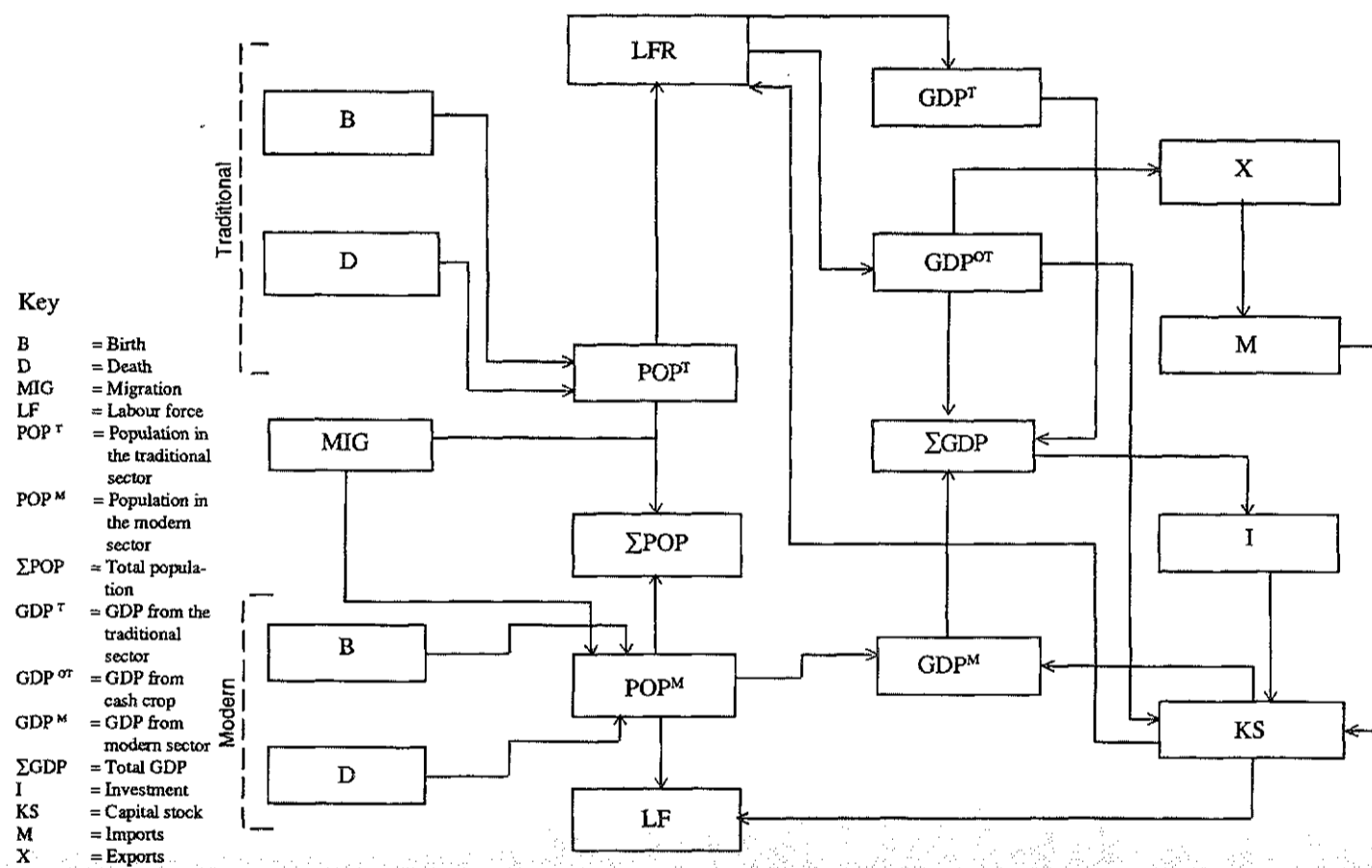

Figure 1 Schematic presentation of economic-demographic interaction

III. Mathematical formulation of the model

Having classified the economy into traditional and modern sectors, along with government and the rest of the world sectors, we now present the functional relations for our macroeconomic demographic model. The model will contain economic and demographic sub-models.

The economic sub-model

There will be three production functions, two for the agricultural sector and one for the non-agricultural sector. The agricultural production function will be for cash and other crops. A Cobb Douglas-type production function will be assumed. The models are:

- (1) $YAC = f_1(L^b, L_a^c)$
- (2) $YAO = f_2(L^b, L_a^o)$
- (3) $YNA = f_3(L^{b'}, K^A)$
- (4) $Y = YAC + YAO + YNA$
- (5) $L = L^b + L^{b'} + L^o$

In the above specification, YAC , YAO , YNA are outputs of agricultural cash crops, other agriculture and non-agricultural output, respectively; L^b , $L^{b'}$, L^o are labour inputs; L_a^c and L_a^o land cultivated; K^A is capital input in the non-agricultural sector; and L is the total labour force.

Consumption

There will be two different consumption functions, one for the private sector and another for government. Because of data constraints, different consumption

functions for the traditional and modern sector could not be specified. The two functions are:

- (5) Private consumption $CP = f_5(YD, CP-1)$
 (6) Government consumption $CG = f_6(Y, P)$
 (7) Aggregate consumption $C = CP + CG$

YD , P and C are per capita GDP, population and consumption, respectively.

The foreign trade sector

This sector will be represented by four equations—two for the export of coffee and other items, and two for the import of oil and other commodities.

The export equation:

- (8) $X^C = f_8(Q^C, P^C)$
 (9) $X^O = f_9(P^O)$
 (10) $X = X^C + X^O$

In the above functions, X^C and X^O represent export of coffee and of other commodities, respectively, and X is the aggregate export, Q^C , P^C and P^O represent the amount of coffee produced and price indices of coffee and other commodities, respectively.

The import equation:

- (11) $M^F = f_{11}(X_{-1}, Y_p, P^F)$
 (12) $M^O = f_{12}(X_{-1}, Y_p, P^O)$
 (13) $M = M^F + M^O$

Again, M^F and M^O represent imports of fuel and other commodities, respectively, while M is the aggregate value of the same. Both equations are functions of lagged total export (X_{-1}), the respective import price indices and per capita income.

The economic sub-model assumes that at an equilibrium point aggregate output equals aggregate demand. The sub-model is closed by the identity which states that investment is total income less consumption plus net exports.

- (14) $I = (Y - C - X + M)$

The demographic sub-model

Fertility and mortality

There are various ways of modelling the demographic behavioural equations and identities. Assuming that data would be available, the most effective way of capturing the determinants of demographic variables would be to follow the lines suggested by Tung (1984). In the latter's study, demographic sub-models were classified into age-specific fertility rate, labour force participation rate and mortality or survival rates. Unlike Tung's paper, the above specification would not have a separate estimation for male and females. Also, we will not differentiate between total labour force and labour force participation rate.

There are many socio-economic variables that determine age-specific fertility and survival rates. To include all possible determinants would not be feasible due to data constraints. Simon (1976) goes to the extent of stating that the inclusion of too many explanatory variables may not be sensible. Tung and Simon suggest a single but common composite explanatory variable which is income per equivalent adult consumer. In our case, we will apply income per capita as an explanatory variable. We will have separate functions for the rural and urban population.

$$(15-21) \quad ASFR_a^R = f_{15-21}(YRUR)$$

$$(22-28) \quad ASFR_a^U = f_{22-28}(YUR)$$

$$a = 1, 2, \dots, 7$$

$$(29-41) \quad ASSR_{a'} = f_{29-41}(YRUR)$$

$$a' = 1, 2, \dots, 13$$

In the above functions, $ASFR_a^U$ and $ASFR_a^R$ are age-specific fertility rate of urban and rural women where the age of the women is grouped by the conventional five-year intervals; $ASSR_{a'}$ is average age-specific survival rate of rural and urban population; a' is the conventional five-year interval, the upper limit of which is 65 years and above. $YRUR$ and YUR are the per capita income of the rural and urban populations respectively.

Estimating the age-specific fertility and mortality rates will give us an indication of the effects of changing age distribution. Once these age-distribution effects are identified, we will be able to project the population. One of the most common methods of population projection, namely the "component method", will be applied in the process of projection. After the component method is applied to forecast age-specific future population for each sub-sector, the total population will be obtained by aggregation.

Internal migration

Internal migration is another demographic variable that has an effect on the growth distribution of the population, as well as on the labour force. One of the major reasons for classifying the economy into modern and traditional sectors would be to study rural-urban migration, its rates and determinants. Internal migration in developing countries has been studied by Lewis (1954), Niho and Sato (1971), Yap (1976), and others through the "dualism" concept.

Many economists have tried to identify the major determinants of migration. By far the most important determinant of urban rural migration is the income differential between the agricultural (traditional) and modern sectors. The migration equation will not be age specific and will be given as follows:

$$(42) \text{ MIG} = f_{56} (\text{YUR} - \text{YRUR})$$

Where *MIG* is the number of net migrants to urban areas.

IV. Data sources

Generally, it is not easy to obtain all the necessary time-series data for estimating the preceding model. It is even more difficult when one tries to estimate the relatively complex model for Ethiopia.

Time-series data that are reliable, up to date and internally consistent are hard to come by. However, an attempt was made to collect the necessary information. Information on GDP and its various components was obtained from various annual publications such as the *Ethiopian Statistical Abstracts*, as well as from Annual Reports of the National Bank of Ethiopia. GDP and its various components are given in Ethiopian currency (Birr). The same is true for private and government consumption as well as various components of export and import. Also acreage planted and labour input is given in hectares and number of workers respectively. On the other hand all prices are given in relative terms. These data are satisfactory. However, the demographic variables were available only for selected years, and various methods of extrapolation were used to fill in the missing values. Table 1 shows the mean variance and minimum and maximum values of some relevant variables. The table shows that the data seem to be within acceptable limits.

Table 1 Summary statistics of selected economic demographic variables*

	Mean	Standard deviation	Minimum	Maximum
ASSR 0-4	0.858	0.004	0.852	0.865
ASSR 20-24	0.966	0.005	0.958	0.973
ASSR 50-54	0.870	0.003	0.849	0.901
ASFR _t 25-29	0.255	0.001	0.254	0.256
ASFR _R 25-29	0.259	0.038	0.219	0.333
YAO	5840.250	967.009	4099.0	7419.0
CP	5010.520	1946.864	2447.0	8132.0
X ^R	326.619	178.540	139.0	593
M ^F	123.942	121.242	29	423
PC	1.339	0.951	0.59	3.46
PF	1.289	0.665	0.45	2.49

* Some of the observations are measured in physical quantities while others are in money terms.

V. Results and applications

Both Ordinary Least Square (OLS) and 2SLS were applied in estimating the behavioural equations. The two methods give similar results, and OLS estimates are given in Tables 2 and 3. Only the functional forms that give a better fit are presented.

Table 2 Regression of age-specific fertility rates

Age group	Urban			Rural		
	Intercept	Slope	Adjusted R ²	Intercept	Slope	Adjusted R ²
15-19	0.109 (21.84)	-0.001 (-6.21)	0.79	-0.184 (-4.05)	0.005 (6.74)	0.78
20-24	0.271 (199.48)	-0.0002 (-16.06)	0.96	-0.067 (-1.35)	0.005 (5.96)	0.73
25-29	0.252 (1213.76)	-0.0001 (12.669)	0.94	0.864 (4.23)	-0.009 (-2.96)	0.75
30-34	0.233 (86.22)	-0.0003 (-13.90)	0.95	0.383 (11.54)	-0.003 (-6.15)	0.74
35-39	0.121 (128.64)	0.0001 (12.04)	0.94	0.315 (5.61)	-0.003 (-3.207)	0.42
40-44	0.014 (5.13)	0.0004 (15.40)	0.96	0.365 (8.53)	-0.005 (-6.98)	0.79
45-49	0.179 (0.511)	-0.0008 (-0.19)	-0.11	-0.003 (-0.14)	0.001 (1.761)	0.14

Table 3 Regression of age-specific survival rates for rural and urban areas*

Age group	Intercept	Slope	Adjusted R ²
0-4	1.367 (29.599)	-0.003 (-11.529)	0.923
5-9	1.367 (29.599)	-0.003 (-11.529)	0.923
10-14	0.928 (150.626)	0.0003 (7.626)	0.839
15-19	0.946 (11.462)	0.0002 (11.462)	0.922
20-24	0.932 (315.33)	0.0002 (11.551)	0.923
25-29	0.952 (752.303)	0.0001 (11.551)	0.923
30-34	0.906 (178.881)	0.0003 (11.551)	0.923
35-39	0.949 (499.640)	0.0001 (11.551)	0.923
40-44	0.894 (162.983)	0.0004 (11.551)	0.923
45-49	0.911 (499.00)	0.0030 (252.00)	0.999
50-54	1.781 (3.649)	0.0001 (11.885)	0.923
55-59	0.850 (92.855)	0.0001 (9.597)	0.851
60-64	0.721 (51.743)	0.0010 (11.551)	0.923

* An average of the rural and urban survival rates was included.

The economic sub-model

Agricultural production functions

Cash crop

$$\ln YAC = -1.20 + .16 \ln L^b + 1.55 \ln L_a^c$$

(-8.23) (1.54) (14.05)

$$\bar{R}^2 = .93 \text{ F}(2, 15) = 112.22$$

Other crops

$$\ln YAO = 6.425 + .060 \ln L^b + 0.351 \ln L_a^c$$

(9.82) (1.16) (3.45)

$$\bar{R}^2 = 0.37, F(2, 15) = 5.97$$

Non-agricultural production functions

$$\ln YNA = 2.916 + 0.181 \ln L^b + 0.787 \ln KA$$

(1.10) (3.78) (1.71)

$$\bar{R}^2 = 0.65, F(2, 12) = 14.01$$

Government consumption

$$CG = -1509.910 + 0.13Y + 49.65P$$

(2.11) (0.9)

$$\bar{R}^2 = 0.96, F(2, 18) = 265$$

Private consumption

$$CP = -18.927 + 0.98 YD$$

(-4.89) (42.86)

$$\bar{R}^2 = 0.99, F(1, 12) = 1.836$$

Coffee exports

$$X^c = -53.958 + 129.79 P^c + 1.009 Q^c$$

(-0.257) (3.014) (0.758)

$$\bar{R}^2 = 0.65, F(2, 13) = 15.01$$

Other exports

$$\ln X^o = 102.793 + 155 P^o - 1$$

(2.194) (2.762)

$$\bar{R}^2 = 0.306, F(1, 14) = 7.63$$

Fuel imports

$$M^f = -184.935 + 9.657 P^f - 1 + 0.47 Y_p + 0.477 X - 1$$

(-1.402) (0.491) (0.340) (2.660)

$$\bar{R}^2 = 0.89, F(3, 2) = 42.36$$

Other imports

$$M^o = -634.487 + 6.995 Y_p + 0.241 X - 1$$

(-2.529) (2.630) (0.681)

$$\bar{R}^2 = 0.88, F(2, 14) = 58.60$$

Migration

$$Mig = 0.423 + 0.001 Diff$$

(42.22) (28.51)

$$\bar{R}^2 = 0.98, F(1, 12) = 812.72$$

The empirical results of the economic submodel exhibit high explanatory variables and seem to be satisfactory. However, there are some equations that seem to be peculiar and deserve explanation. The cash crop production function seems to exhibit increasing returns to scale. In this equation the contribution of acreage seems to be quite important while labour's contribution, though positive, was found to be non-significant. The result suggests that land is scarce to labour and hence there may be higher return from one extra hectare of land than the corresponding one extra unit of labour input. On the other hand, the marginal product of labour in the non-agricultural sector seems to be positive and significant.

The marginal propensity to consume, which is 0.98, suggests that the aggregate saving rate is only 2 percent of the disposable income, and this is not unusual in a country that registers the lowest per capita income in the world and has frequent droughts and famines.

Both the coffee and other export equations give the predicted result, suggesting that farmers tend to react to changes in the price of exportable products in the predictable manner. The import of fuel and other commodities is heavily affected by lagged export earnings; while price does not seem to have an effect on fuel imports, per capita GDP seems to have a positive and significant effect on the import of non-fuel items.

The demographic sub-model

Like the economic sub-model, the demographic sub-model seems to show satisfactory results. However, in some age groups the relation between fertility, on the one hand, and the explanatory variable (income), on the other did seem to be counter-intuitive. This is especially so in the later stages of women's reproductive period. Moreover, the explanatory power of the fertility equations at ages 45-49 is quite low. The reason for such a result may be the low number of observations within this age group. The age-specific survival rate in Table 3 suggest that there is little difference in the relation between age-specific survival rate and per capita GDP for most of the age groups. The unexpected negative sign of the slope among the age category 5-9 may be attributed to the possible age misreporting among this group.

In general, one can use the economic and demographic estimates for simulation purposes.

Simulation

Having specified the economic-demographic sub-models, we now attempt to show the interaction between the two.¹ This is done by changing the coefficients

of the demographic sub-model and studying its effect on various components of the economic variables, such as aggregate and per capita GDP as well as GDP per adult equivalent consumer. Our approach is similar to that followed by Tung (1984). The steps that we will follow are:

- (a) Fertility was reduced by shifting the constant term of the age-specific fertility equations by 25 and 50 percent, respectively.² It is assumed that mortality rates will behave in the future in the same as they did in the past.
- (b) Based on the assumption in (a) we re-estimated the rate of population growth and projected the Ethiopian population by the conventional five-year groups. The projected population is for both rural and urban centres and for the years 2000 and 2010. The year 1985 is the initial period. Rural-urban migration was also taken into consideration in the projection of the population. The results are given in the upper part of Table 4.

The labour force in both rural and urban centres for the two projected periods is given and this was integrated with the relevant production functions within the economic sub-model. We then estimated the GDP from cash, non-cash and non-agriculture. This was added so as to get the overall GDP for the years 2000 and 2010. When forecasting the various components of the GDP, we assume that acreage, capital input and investment will continue to increase at the same rate as they did in the past. The projected economic variables are given in the lower part of Table 4.

The projected components of GDP suggest that the cash crop cultivation will constitute a larger portion of agricultural production both in terms of acreage and exported revenues. This is because of the relatively elastic response of yield to acreage cultivated. Non-agricultural production will also make up a larger portion of GDP in the years 2000 and 2010. The projected results also suggested a longer growth of export earning compared to import payments.

The results show that the 15–14-year-old agricultural labour force will be increased by 21 and 39 percent, respectively for the two forecast periods. For the non-agricultural sector, the labour force will be increased by 1.86 and 4.2 times for the two forecast periods, respectively. Based on this assumption, a reduced population growth will mean that the GDP will increase by only 75 and 188 percent for the two periods. On the other hand, per capita GDP will increase by 36 and 94 percent for a lower fertility reduction. A significant increase is observed when one considers GDP per adult equivalent consumer³ as well as higher fertility reduction.

Table 4 Projected economic and demographic variables under reduced fertility schedules

Age Group	1985		2000				2010			
	Rural	Urban	1	2	1	2	1	2	1	2
1. Demographic variables										
0-4	7.02	0.62	5.56	1.30	3.83	0.89	5.87	1.15	3.83	1.08
5-9	5.85	0.44	6.28	1.48	3.42	0.80	6.62	1.87	3.42	0.96
10-14	4.88	0.54	4.96	1.18	3.22	0.76	5.29	1.49	3.22	0.91
>55	2.23	0.25	3.01	0.71	4.45	1.10	3.34	0.94	4.91	1.38
15-54	20.90	2.07	25.39	5.93	27.1	6.28	29.03	8.70	28.85	8.14
2. Economic variables										
	1985		2000				2010			
GDP from:			1	2	1	2	1	2		
Cash crops	1,030		1,536	1,568	2,362	2,362				
Other crops	1,526		1,523	1,532	1,673	1,673				
Non-agriculture	1,247		3,626	3,666	4,582	4,500				
Exports	1,314		1,611		1,669					
Imports	1,325		1,505		1,897					
Investment	733		963		1,115					
GDP at f.c.	4,525		7,754	7,434	9,504	9,422				
GDP per capita	101		138.8	143.3	147.9	166.1				
GDP per adult equivalent	121.1		159.3	157.0	181.0	204.2				

1 = 25 percent reduction in the constant term.

2 = 50 percent reduction in the constant term.

VI. Conclusion

The preceding estimation and simulation process showed that one *can* get some insight into economic-demographic interactions, and that the use of demographic variables as policy instruments could yield a higher per capita income in general and per adult equivalent consumer in particular. The results are based on the assumption that the given state of technology, and the capital labour ratio, will not change significantly. The overall investment, as well as acreage planted, will increase at the same rate as in the past. If a lower fertility rate yields higher per capita GDP, the next question will be how to go about reducing the current high rate (3.0 percent) of population growth in Ethiopia. Obviously it would be impossible to reduce the total fertility rate from 6.6 to 3.4 within a decade or two. However, a start may have to be made.

Notes

1. It will be assumed that the age-specific survival rate of the rural and urban population will decrease at the same rate in the future as it did in the past.
2. A 25–50 percent decrease in the constant term implied a reduction in total fertility rate from 6.6 to 3.4 and 1.9 in the years 2000 and 2010, respectively, for the rural population. For the urban population, this would mean a reduction from 6.21 to 3.72 and 2.06 for the same years.
3. The urban and rural population of Ethiopia in terms of adult equivalents is given as follows:
 $0-4 = 0.45$, $5-9 = 0.65$, $10-14 = 0.85$, $15+ = 1.0$.

References

- Coale, A.J. and Hoover, E.M. 1958. *Population Growth and Economic Development in Low Income Countries*. Princeton: Princeton University Press.
- Enke, S. 1974. "Reducing fertility to accelerate development." *Economic Journal* 84: 349-366.
- . 1971. "The economic consequences of rapid population growth." *Economic Journal* 81: 800-811.
- Gillman, K. 1981. "Julian Simon's cracked crystal ball." *The Public Interest* 65: 71-80.
- Government of Ethiopia. 1974. Tables of demographic data, Vol. 1-111. *Statistical Bulletin* No. 10. Addis Ababa.
- Government of Ethiopia. 1979. Report on the analysis of the Addis Ababa Demographic Survey. *Statistical Bulletin* No. 22. Addis Ababa.
- Kidane, A. 1987. "Determinants of savings in Ethiopia with reference to the role of demographic variables." *East Africa Economic Review* 3(2): 21-31.
- . 1987. Re-estimating the Ethiopian population by age and geographical distribution." *NEAS*: 9(3) 59-73.
- Leff, N.N. 1969. "Dependency rates and aggregate saving rates." *AER* 59: 886-896.
- Lewis, W.A. 1954. *Economic Development with Unlimited Supply of Labour*. Manchester School.
- McIntosh, J. 1978. "The econometrics of growth and underdevelopment: A test of dual hypotheses." *RES* 42: 421-33.
- Marehead, R.S. 1982. "Population, internal migration and economic growth." In J. Simon (ed.), *Research in Population Economics*. Greenwich: JAI Press, pp.173-216.
- Mueller, E. 1976. "The economic value of children in Peasant Agriculture." In R.G. Ridker (ed.), *Population and Development: A Search for Selective Intervention*. Baltimore: Johns Hopkins University Press.
- Niho, Y. and Sato, R. 1971. "Population growth and the development of a dual economy." *Oxford Economic Papers*.
- Notestein, F. 1945. "Population: The long view." In W. Schultz (ed.), *Food for the World*. Chicago: University of Chicago Press.
- Simon, J. 1976. "Income, wealth and their distribution as policy tools in fertility control." In R.G. Ridker (ed.), *Population and Development: A Search for Selective Interventions*. Baltimore: Johns Hopkins University Press.
- Tung, S.L. 1984. "An econometric analysis of the effects of population change on economic growth: A study of Taiwan." *Applied Economics* 16: 523-538.
- Yap, L. 1976. "Internal migration and economic development in Brazil." *Quarterly Journal of Economics*.



AFRICAN ECONOMIC RESEARCH CONSORTIUM

P.O. BOX 47543
NAIROBI, KENYA

TELEPHONE (254-2) 228057 225234
215898 212359 332438 225087

TELEX 22480

FAX (254-2) 219308

The principal objective of the African Economic Research Consortium (AERC), established in August 1988, is to strengthen local capacity for conducting independent, rigorous inquiry into problems pertinent to the management of economies in Sub-Saharan Africa.

In response to special needs of the region, AERC has adopted a flexible approach to improve the technical skills of local researchers, allow for regional determination of research priorities, strengthen national institutions concerned with economic policy research, and facilitate closer ties between researchers and policymakers.

Since its establishment, AERC has been supported by private foundations, bilateral aid agencies and international organizations.

SPECIAL PAPERS contain the findings of commissioned studies in furtherance of AERC's programmes for research, training and capacity building.

RESEARCH PAPERS contain the edited and externally reviewed results of research financed by the AERC.

It is AERC's policy that authors of Special and Research Papers are free to use material contained therein in other publications. Views expressed in the Special and Research Papers are those of the authors alone and should not be attributed to the AERC's sponsoring Members, Advisory Committee, or Secretariat.

Further information concerning the AERC and additional copies of Special and Research Papers can be obtained by writing to: African Economic Research Consortium, P.O. Box 47543, Nairobi, Kenya.

ISBN 9966-42-030-4

This work is licensed under a
Creative Commons
Attribution – NonCommercial - NoDerivs 3.0 Licence.

To view a copy of the licence please see:
<http://creativecommons.org/licenses/by-nc-nd/3.0/>